

FXyBx 2 axes / IO

● Arm type ● Cable carrier

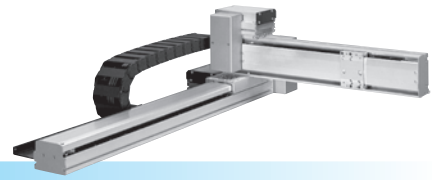

Ordering method

FXyBx - C				IO		RCX222				
Model	Cable	Combination	X-axis stroke	Y-axis stroke	ZR-axis	Cable length	Controller	Usable for CE	Input/Output selection 1	Input/Output selection 2
		A1 A2 A3 A4	15 to 245cm	15 to 55cm		3L: 3.5m (Standard) 5L: 5m 10L: 10m	RCX222 DRCX0505	No entry: Standard E: CE marking	N: NPN ^{Note 1} P: PNP CC: CC-Link DN: DeviceNet PB: Profibus EN: Ethernet ^{Note 1} YC: YC-Link ^{Note 2}	No entry: None Nf: OP.DIO24/16 (NPN) ^{Note 1} Pf: OP.DIO24/17 (PNP) EN: Ethernet ^{No. 1} ^{Note 3}

Note 1. NPN and Ethernet cannot be selected if using CE marking.
Note 2. Available only for the master.
Note 3. Only when CC or DN or PB was selected for I/O select 1 above. EN can be selected in I/O select 2.

Specification

	X-axis	Y-axis
Axis construction ^{Note 1}	B10	-
AC servo motor output (W)	100	100
Repeatability ^{Note 2} (mm)	+/-0.04	+/-0.04
Drive system	Timing belt	Timing belt
Ball screw lead (Deceleration ratio) (mm)	Equivalent to lead 25	Equivalent to lead 25
Maximum speed (mm/sec)	1875	1875
Moving range (mm)	150 to 2450	150 to 550
Robot cable length (m)	Standard: 3.5 Option: 5,10	

Note 1. Use caution that the flame machining (installation holes, tap holes) differs from single-axis robots'.
Note 2. Positioning repeatability in one direction.

Maximum payload (kg)

Y stroke (mm)	XY 2 axes
150	7
250	6
350	5
450	5
550	3

Controller

Controller	Operation method
RCX222	Programming / I/O point trace / Remote command / Operation using RS-232C communication
DRCX0505	

FXyBx 2 axes / IO (A1)

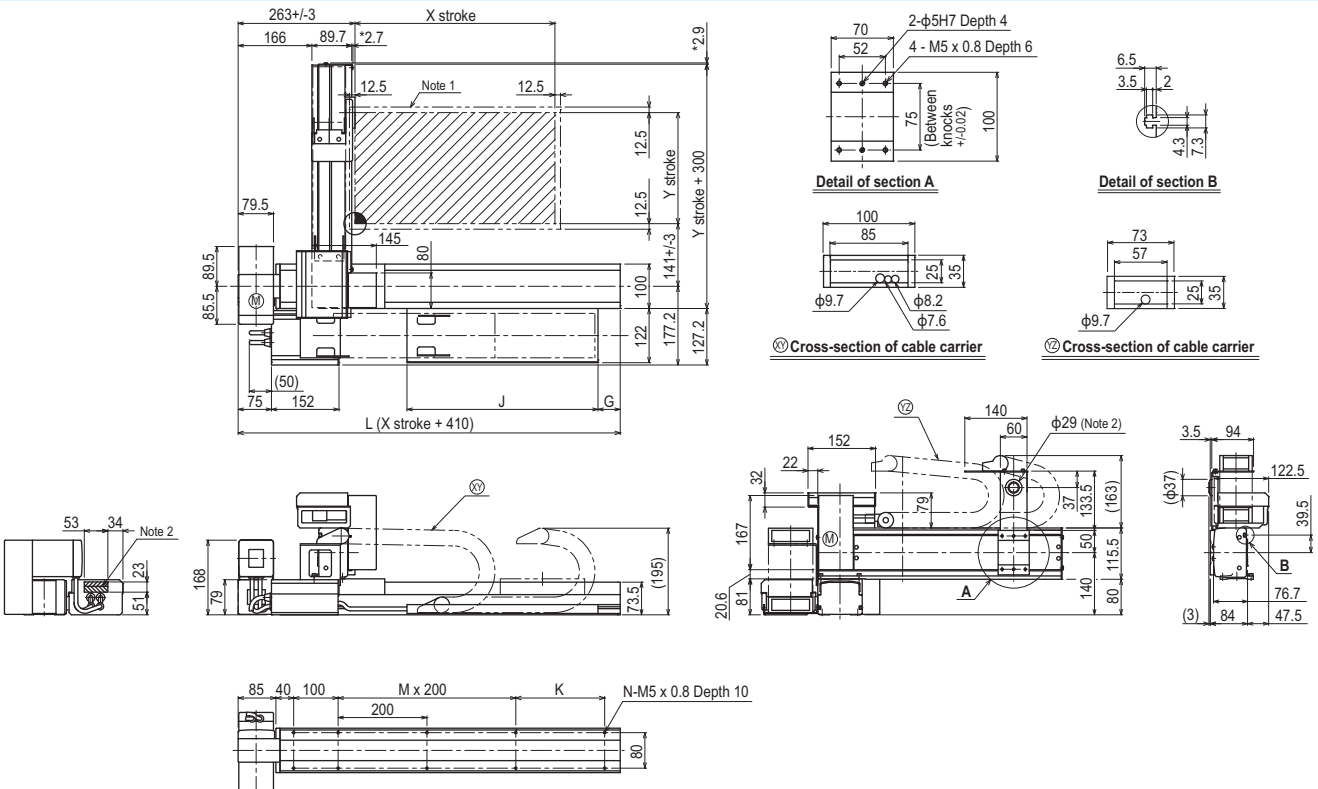

Note 1. The moving range when returning to origin and the stop position when stopping by the mechanical stopper. Note 2. The shaded position indicates a user cable extraction port. Note 3. The dimension marked with an asterisk (*) indicates the height of the screw.

X stroke	150	250	350	450	550	650	750	850	950	1050	1150	1250	1350	1450	1550	1650	1750	1850	1950	2050	2150	2250	2350	2450
L	560	660	760	860	960	1060	1160	1260	1360	1460	1560	1660	1760	1860	1960	2060	2160	2260	2360	2460	2560	2660	2760	2860
K	100	200	100	200	100	200	100	200	100	200	100	200	100	200	100	200	100	200	100	200	100	200	100	200
M	1	1	2	2	3	3	4	4	5	5	6	6	7	7	8	8	9	9	10	10	11	11	12	12
N	8	8	10	10	12	12	14	14	16	16	18	18	20	20	22	22	24	24	26	26	28	28	30	30
G	0	50	0	50	0	50	0	50	0	50	0	50	0	50	0	50	0	50	0	50	0	50	0	50
J	330	330	430	430	530	530	630	630	730	730	830	830	930	930	1030	1030	1130	1130	1230	1230	1330	1330	1430	1430
Y stroke	150	250	350	450	550																			