

YAMAHA
ROBOT



Estratto Catalogo Yamaha
Pick&Place alta velocità (Serie YP-X)

YP-X Series

Product Lineup

PICK & PLACE ROBOTS

Ideal for small components high-speed pick & place work.
Positioning is made by servo control, so no complex mechanical
adjustments are needed.



Full lineup of 6 models in all from 2 axes to 4 axes

2 axes type

P.429

3 axes type

P.431

4 axes type

P.434



YP220BX/YP320X

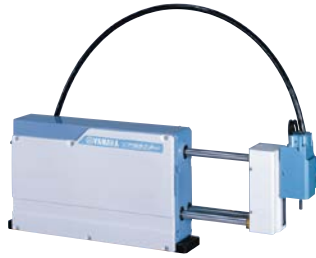

YP220BXR/YP320XR/YP330X



YP340X

Model	Axis	Structure				Maximum payload (kg)	Cycle time (sec.)	Page
		X-axis	Y-axis	Z-axis	R-axis			
YP220BX	2 axes	Belt	-	Belt	-	3	0.45	P.429
YP320X		Ball screw	-	Belt	-	3	0.57	P.430
YP220BXR	3 axes	Belt	-	Belt	Rotation axis	1	0.62	P.431
YP320XR		Ball screw	-	Belt	Rotation axis	1	0.67	P.432
YP330X		Ball screw	Ball screw	Belt	-	3	0.57	P.433
YP340X	4 axes	Ball screw	Ball screw	Belt	Rotation axis	1	0.67	P.434

POINT 1

High speed

Super high-speed pick & place operation with a standard cycle time of 0.45 sec. (YP220BX with up/down 50 mm, back/forth 150 mm, arch amount 50, load 1 kg) greatly contributes to improvement of the productivity. Since it is possible to output a signal to turn on/off any external equipment from any position while the axis is moving, the actual production cycle time is further improved.

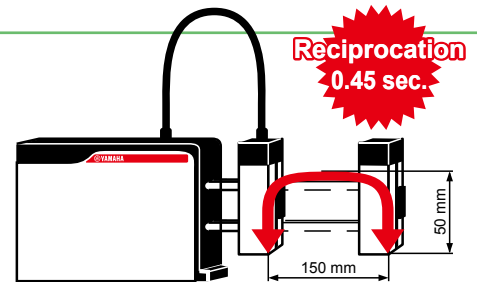

POINT 2

Compact

Use of a compact size with an overall width of 109 mm (YP220BX) makes it possible to make the production line compact and simple. The moving arm structure with less interference with surroundings contributes to space saving.

Reference examples of robot layout comparisons

■ Line using pick & place utilizing space saving

■ Line using YAMAHA's compact Cartesian robot PXYx
X-axis stroke: 250 mm
Y-axis stroke: 250 mm

■ Line using YAMAHA's compact SCARA robot YK250X

The compactness can be checked by comparing the occupied spaces when the YP-X series and YAMAHA's Cartesian/SCARA robots are laid out.

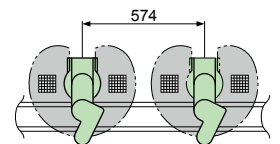
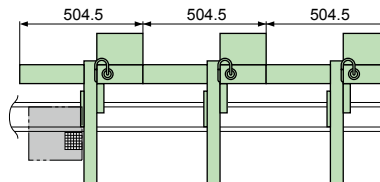
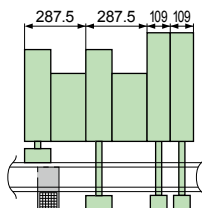

POINT 3

High accuracy

Both extremely high-speed performance and high repeated positioning accuracy of +/- 0.02 mm (YP320X, YP320XR, YP330X, YP340X) are assured.

POINT 4

Complete absolute position system

As the complete absolute position system is used, no return-to-origin operation is needed.

POINT 5

Versatility

Use of YAMAHA's unique servo system makes it possible to freely program the stop point and operation pattern settings. This robot is applicable to production of many models in small quantities that cannot be supported by the cam type robot.

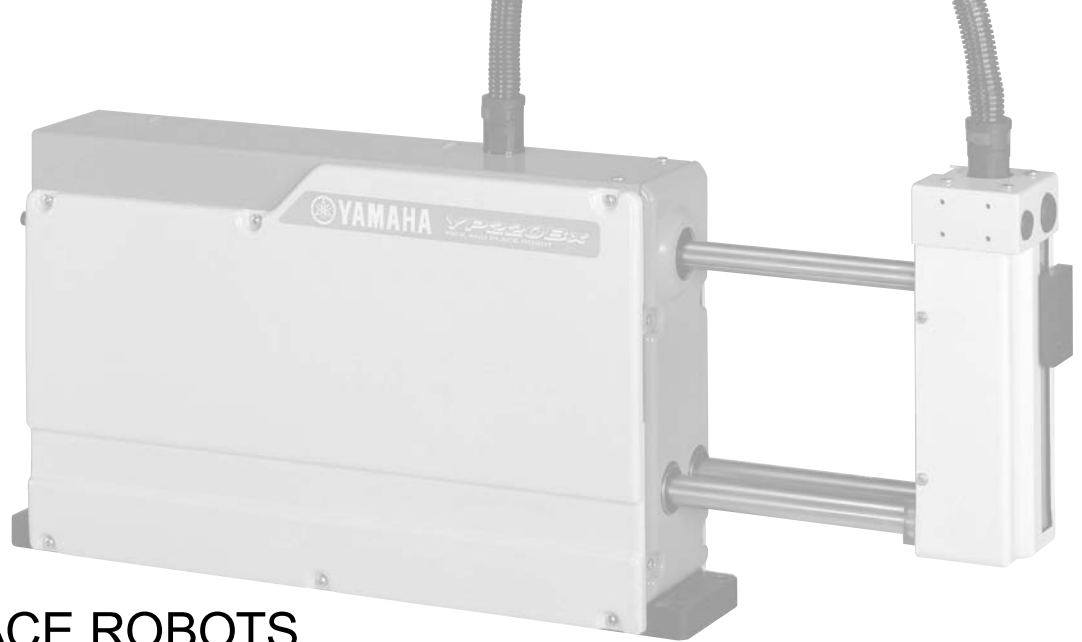

PICK & PLACE ROBOTS

YP-X SERIES

CONTENTS

■ YP-X SPECIFICATION SHEET	428
■ Robot ordering method description	428
■ Robot ordering method terminology	428
2 AXES	
YP220BX	429
YP320X	430
3 AXES	
YP220BXR	431
YP320XR	432
YP330X	433
4 AXES	
YP340X	434

Articulated robots
YA

Linear conveyor modules
LCM100

Compact single-axis robots
TRANSERVO

Single-axis robots
FLIP-X

Linear motor single-axis robots
PHASER

Cartesian robots
XY-X

SCARA robots
YK-X

Pick & place robots
YP-X

CLEAN

CONTROLLER

INFORMATION

2-axes

3-axes

4-axes

YP-X SPECIFICATION SHEET

Type	Model	Maximum payload (kg)	Cycle time (sec) ^{Note 1}	Structure		Moving range	Detailed info page
2-axes	YP220BX	3	0.45	X-axis	Belt	200mm	P.429
	YP320X	3	0.57	Z-axis	Belt	100mm	P.430
3-axes	YP220BXR	1	0.62	X-axis	Belt	200mm	P.431
				Z-axis	Belt	100mm	
	YP320XR	1	0.67	X-axis	Ball screw	330mm	P.432
				Z-axis	Belt	100mm	
YP330X	3	0.57	R-axis	Rotation axis	+/-180°	P.433	
			X-axis	Ball screw	330mm		
4-axes	YP340X	1	0.67	Y-axis	Ball screw	150mm	P.434
				Z-axis	Belt	100mm	
				X-axis	Ball screw	330mm	
				R-axis	Rotation axis	+/-180°	

Note 1. Cycle time is the time required for moving back and forth 150mm (arch 50) and vertically 50mm (during rough-positioning motion with 1kg load).

Robot ordering method description

In the order format for the YAMAHA pick & place robots YP-X series, the notation (letters/numbers) for the mechanical section is shown linked to the controller section notation.

[Example]

■ 2-axis specifications

● Mechanical ▶ YP220BX

- Robot cable length ▶ 3.5m

● Controller ▶ RCX222

- Usable for CE ▶ Not required
- Input/Output selection 1 ▶ NPN
- Input/Output selection 2 ▶ None

● Ordering method

YP220BX-3L-RCX222-N

Mechanical section

Controller section

① Model		② Cable length		③ Controller		④ Usable for CE		⑤ Input/Output selection 1		⑥ Input/Output selection 2	
YP220BX	3L	3.5m	RCX222	No entry	N	NPN ^{Note 1}	No entry	None			
YP320X	5L	5m		E	P	PNP		N1	OP.DIO 24/16 (NPN) ^{Note 1}		
	10L	10m			CC	CC-Link		P1	OP.DIO 24/17 (PNP)		
					DN	DeviceNet™		EN	Ethernet ^{Note 3}		
					PB	PROFIBUS		YC	YC-Link ^{Note 2}		

Note 1. With the CE marking, it is not possible to select NPN or Ethernet.

Note 2. Available only for the master.

Note 3. Only when CC-Link or DeviceNet™ or PROFIBUS was selected for I/O select 1 above. Ethernet can be selected in I/O select 2.

■ 3 / 4 axis specifications

● Mechanical ▶ YP340X

- Robot cable length ▶ 5m

● Controller ▶ RCX240S

● Ordering method

YP340X-5L-RCX240S

Mechanical section

Controller section

① Model		② Cable length		③ Controller	
YP220BXR	3L	3.5m	RCX240S		
YP320XR	5L	5m	RCX340		
YP330X	10L	10m			
YP340X					

To find detailed controller information see the controller page. **RCX222 ▶ P.524**, **RCX240S ▶ P.532**, **RCX340 ▶ P.542**

Robot ordering method terminology

① Model	Enter the robot unit model.
② Cable length	Select the length of the robot cable connecting the robot and controller. 3L: 3.5m 5L: 5m 10L: 10m
③ Controller	2-axis specifications: Select the RCX222. 3 / 4 axis specifications: Select either the RCX240S or RCX340.

YP220BX 2 axes

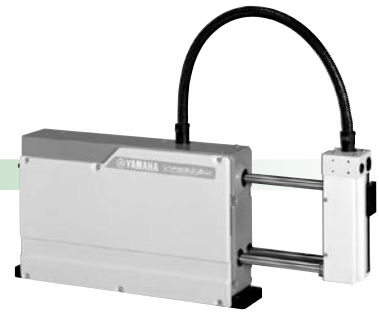

Ordering method

YP220BX		RCX222			
Model	Cable length	Controller	Usable for CE	Inputs/Outputs selection 1	Inputs/Outputs selection 2
	3L: 3.5m 5L: 5m 10L: 10m	RCX222	No entry: Standard E: CE marking	N: NPN ^{Note 2} P: PNP CC: CC-Link DN: DeviceNet™ PB: PROFIBUS EN: Ethernet YC: YC-Link ^{Note 1}	No entry: None N1: OP.DIO24/16 (NPN) ^{Note 2} P1: OP.DIO24/17 (PNP) EN: Ethernet ^{Note 3}

Note 1. Available only for the master.

Note 2. NPN cannot be selected if using CE marking.

Note 3. Only when you have selected CC, DN or PB for Input/Output selection 1, you can select EN for Input/Output selection 2.

Specifications

	X axis	Z axis
AC servo motor output (W)	200	200
Repeatability ^{Note 1} (mm)	+/-0.05	+/-0.05
Drive system	Timing belt	Timing belt
Deceleration ratio (mm)	Equivalent to lead 24	Equivalent to lead 20
Maximum speed ^{Note 2} (mm/sec)	1440	1200
Moving range (mm)	200	100
Cycle time (sec)	0.45 ^{Note 3}	
Maximum payload (kg)	3	
Robot cable length (m)	Standard: 3.5 Option: 5,10	
Weight (kg)	17	

Note 1. Positioning repeatability precision in a single swing when residual vibration is stabilized (variable depending on the load and stroke).

Note 2. When the moving stroke is short, the maximum speed may not be reached.

Note 3. Reciprocating time in vertical direction (50mm) and longitudinal direction (150mm) with the arch amount of 50 (when executing rough-positioning arch motion with 1kg load).

Controller

Controller	Power consumption (VA)	Operating method
RCX222	500	Programming / I/O point trace / Remote command / Operation using RS-232C communication

YP220BX

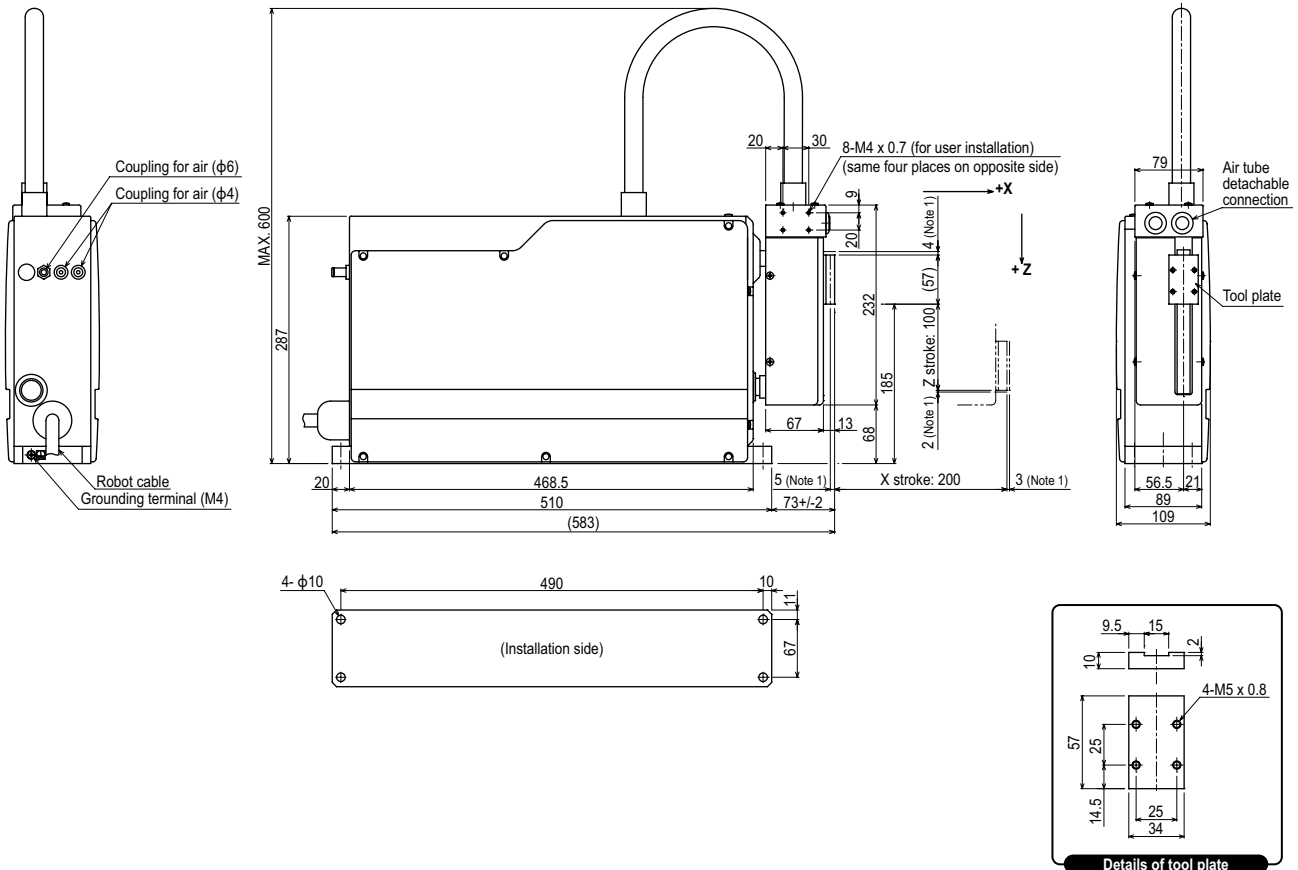

Note 1. Distance to mechanical stopper.

Note 2. Return-to-origin on the YP220BX is by absolute reset. So the origin position must be set the first time (making initial settings) but after that is not required.

Articulated robots
YA

Linear conveyor modules
LCM100

Compact single-axis robots
TRANSEVO

Single-axis robots
FLIP-X

Linear motor single-axis robots
PHASER

Cartesian robots
XY-X

SCARA robots
YK-X

Pick & place robots
YP-X

CLEAN

CONTROLLER INFORMATION

2-axes

3-axes

4-axes

YP320X 2 axes



Ordering method

YP320X		RCX222			
Model	Cable length	Controller	Usable for CE	Inputs/Outputs selection 1	Inputs/Outputs selection 2
	3L: 3.5m 5L: 5m 10L: 10m	RCX222	No entry: Standard E: CE marking	N: NPN ^{Note 2} P: PNP CC: CC-Link DN: DeviceNet™ PB: PROFIBUS EN: Ethernet YC: YC-Link ^{Note 1}	No entry: None N1: OP.DIO24/16 (NPN) ^{Note 2} P1: OP.DIO24/17 (PNP) EN: Ethernet ^{Note 3}

Note 1. Available only for the master.
 Note 2. NPN cannot be selected if using CE marking.
 Note 3. Only when you have selected CC, DN or PB for Input/Output selection 1, you can select EN for Input/Output selection 2.

Specifications

	X axis	Z axis
AC servo motor output (W)	200	200
Repeatability^{Note 1} (mm)	+/-0.02	+/-0.05
Drive system	Ball screw (C7 class)	Timing belt
Deceleration ratio (mm)	Equivalent to lead 20	Equivalent to lead 25
Maximum speed^{Note 2} (mm/sec)	1500	1500
Moving range (mm)	330	100
Cycle time (sec)	0.57 ^{Note 3} , 0.78 ^{Note 4}	
Maximum payload (kg)	3	
Robot cable length (m)	Standard: 3.5 Option: 5,10	
Weight (kg)	21	

Note 1. Positioning repeatability precision in a single swing when residual vibration is stabilized (variable depending on the load and stroke).
 Note 2. When the moving stroke is short, the maximum speed may not be reached.
 Note 3. Reciprocating time in vertical direction (50mm) and longitudinal direction (150mm) with the arch amount of 50 (when executing rough-positioning arch motion with 1kg load).
 Note 4. Reciprocating time in vertical direction (25mm) and longitudinal direction (300mm) with the arch amount of 25 (when executing rough-positioning arch motion with 1kg load).

Controller

Controller	Power consumption (VA)	Operating method
RCX222	500	Programming / I/O point trace / Remote command / Operation using RS-232C communication

YP320X

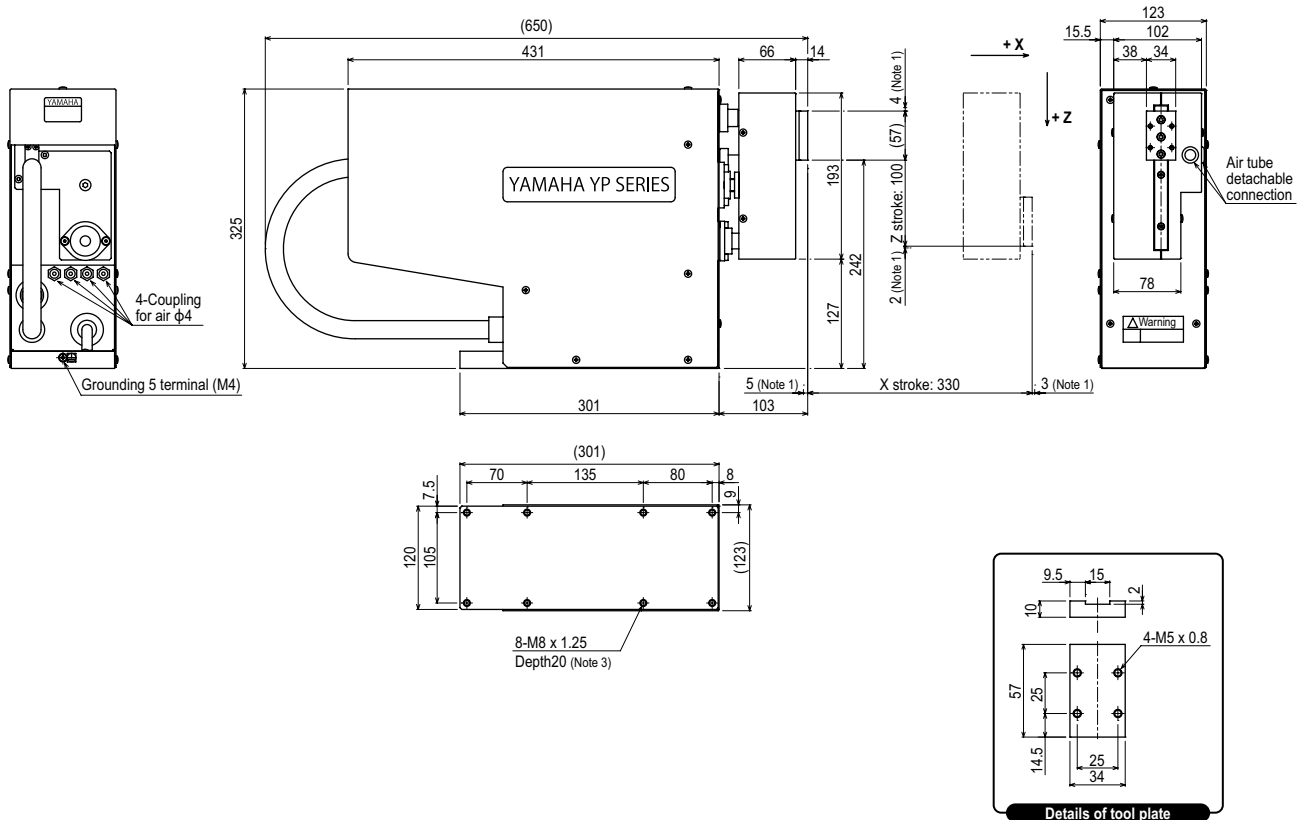

Note 1. Distance to mechanical stopper.
 Note 2. Return-to-origin on the YP320X is by absolute reset. So the origin position must be set the first time (making initial settings) but after that is not required.
 Note 3. Do not use bolts longer than 20mm (robot bottom plate thickness).

YP220BXR 3 axes

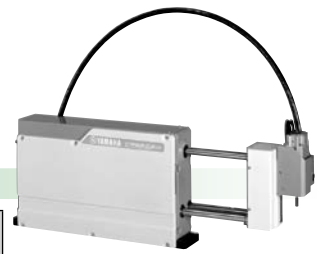

Ordering method

YP220BXR

Model	Cable length
	3L: 3.5m
	5L: 5m
	10L: 10m

RCX340-3

Controller / Number of controllable axes	Safety standard	Option A (OP.A)	Option B (OP.B)	Option C (OP.C)	Option D (OP.D)	Option E (OP.E)	Absolute battery
--	-----------------	-----------------	-----------------	-----------------	-----------------	-----------------	------------------

Specify various controller setting items. RCX340 ▶ **P.542**

RCX240S

Controller	CE Marking	Expansion I/O	Network option	iVY System	Gripper	Battery
------------	------------	---------------	----------------	------------	---------	---------

Specify various controller setting items. RCX240/RCX240S ▶ **P.532**

Specifications

	X axis	Z axis	R axis
AC servo motor output (W)	200	200	60
Repeatability ^{Note 1} (mm)	+/-0.05	+/-0.05	+/-0.1
Drive system	Timing belt	Timing belt	Ball Reducer
Deceleration ratio (mm)	Equivalent to lead 24	Equivalent to lead 20	1/18
Maximum speed ^{Note 2} (XZ: mm/sec) (R: °/sec)	1440	1200	1000
Moving range (XZ: mm) (R: °)	200	100	+/-180
Cycle time (sec)	0.62 ^{Note 3}		
Maximum payload (kg)	1		
R-axis allowable moment inertia (kgm ² [kgfcm ²])	0.00098 [0.01]		
Robot cable length (m)	Standard: 3.5 Option: 5,10		
Weight (kg)	19		

Note 1. Positioning repeatability precision in a single swing when residual vibration is stabilized (variable depending on the load and stroke).
 Note 2. When the moving stroke is short, the maximum speed may not be reached.
 Note 3. Reciprocating time in vertical direction (50mm) and longitudinal direction (150mm) with the arch amount of 50 (when executing rough-positioning arch motion with 1kg load).

Controller

Controller	Power consumption (VA)	Operating method
RCX340 RCX240S	700	Programming / I/O point trace / Remote command / Operation using RS-232C communication

YP220BXR

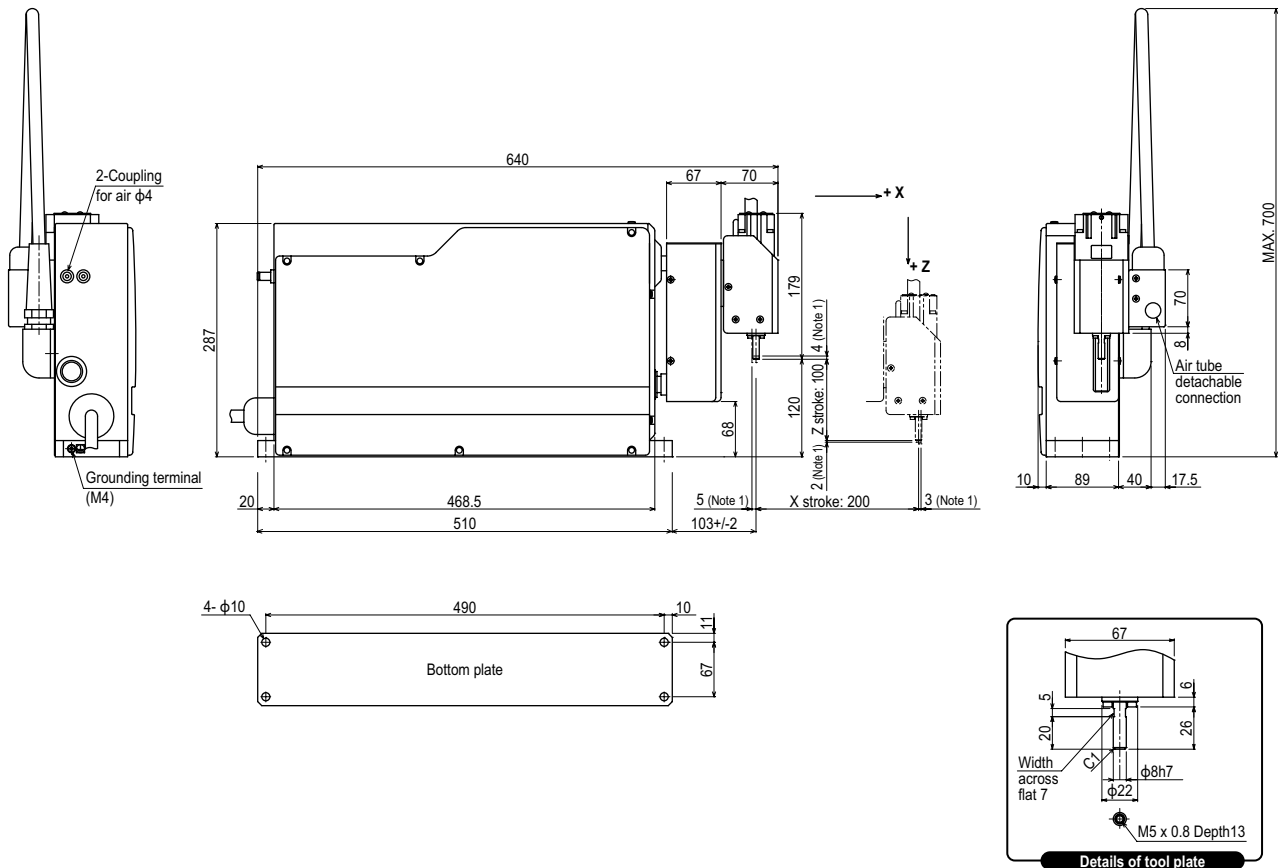

Note 1. Distance to mechanical stopper.
 Note 2. Return-to-origin on the YP220BXR is by absolute reset. So the origin position must be set the first time (making initial settings) but after that is not required.

Articulated robots
YA

Linear conveyor modules
LCM100

Compact single-axis robots
TRANSEVO

Single-axis robots
FLIP-X

Linear motor single-axis robots
PHASER

Cartesian robots
XX-X

SCARA robots
YK-X

Pick & place robots
YP-X

CLEAN

CONTROLLER INFORMATION

2-axes

3-axes

4-axes

YP320XR 3 axes



Ordering method

YP320XR **RCX340-3**

Model **Cable length** **Controller / Number of controllable axes** **Safety standard** **Option A (OP.A)** **Option B (OP.B)** **Option C (OP.C)** **Option D (OP.D)** **Option E (OP.E)** **Absolute battery**

3L: 3.5m
5L: 5m
10L: 10m

Specify various controller setting items. RCX340 ▶ P.542

RCX240S

Controller **CE Marking** **Expansion I/O** **Network option** **iVY System** **Gripper** **Battery**

Specify various controller setting items. RCX240/RCX240S ▶ P.532

Specifications

	X axis	Z axis	R axis
AC servo motor output (W)	200	200	60
Repeatability ^{Note 1} (XZ: mm) (R: °)	+/-0.02	+/-0.05	+/-0.1
Drive system	Ball screw (C7 class)	Timing belt	Ball Reducer
Deceleration ratio (mm)	Equivalent to lead 20	Equivalent to lead 25	1/18
Maximum speed ^{Note 2} (XZ: mm/sec) (R: °/sec)	1500	1500	1000
Moving range (XZ: mm) (R: °)	330	100	+/-180
Cycle time (sec)	0.67 ^{Note 3} , 0.87 ^{Note 4}		
Maximum payload (kg)	1		
R-axis allowable moment inertia (kgm ² [kgfcm ²])	0.00098 [0.01]		
Robot cable length (m)	Standard: 3.5 Option: 5,10		
Weight (kg)	23		

Note 1. Positioning repeatability precision in a single swing when residual vibration is stabilized (variable depending on the load and stroke).
 Note 2. When the moving stroke is short, the maximum speed may not be reached.
 Note 3. Reciprocating time in vertical direction (50mm) and longitudinal direction (150mm) with the arch amount of 50 (when executing rough-positioning arch motion with 1kg load).
 Note 4. Reciprocating time in vertical direction (25mm) and longitudinal direction (300mm) with the arch amount of 25 (when executing rough-positioning arch motion with 1kg load).

Controller

Controller	Power consumption (VA)	Operating method
RCX340 RCX240S	700	Programming / I/O point trace / Remote command / Operation using RS-232C communication

YP320XR

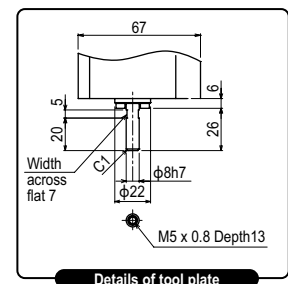
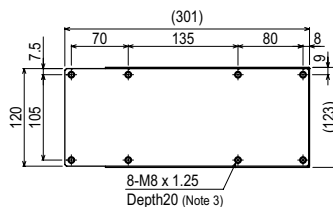
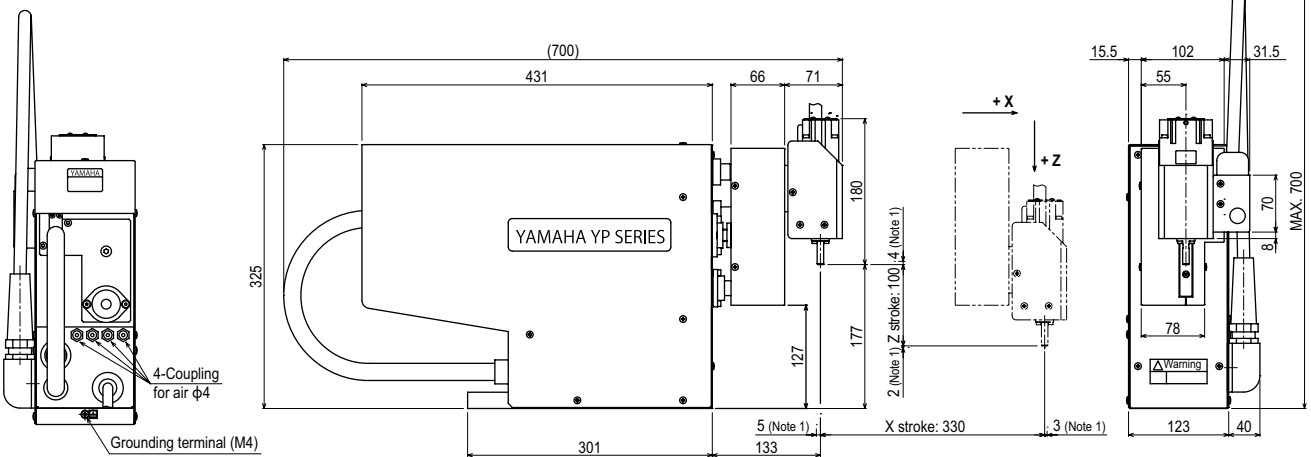

Note 1. Distance to mechanical stopper.
 Note 2. Return-to-origin on the YP320XR is by absolute reset. So the origin position must be set the first time (making initial settings) but after that is not required.
 Note 3. Do not use bolts longer than 20mm (robot bottom plate thickness).

YP330X 3 axes



Ordering method

YP330X

Model

Cable length
3L: 3.5m
5L: 5m
10L: 10m

RCX340-3

Controller / Number of controllable axes

Safety standard

Option A (OP.A)

Option B (OP.B)

Option C (OP.C)

Option D (OP.D)

Option E (OP.E)

Absolute battery

Specify various controller setting items. RCX340 ▶ **P.542**

RCX240S

Controller

CE Marking

Expansion I/O

Network option

iVY System

Gripper

Battery

Specify various controller setting items. RCX240/RCX240S ▶ **P.532**

Specifications

	X axis	Y axis	Z axis
AC servo motor output (W)	200	200	200
Repeatability ^{Note 1} (mm)	+/-0.02	+/-0.02	+/-0.05
Drive system	Ball screw (C7 class)	Ball screw (C7 class)	Timing belt
Deceleration ratio (mm)	Equivalent to lead 20	Equivalent to lead 20	Equivalent to lead 25
Maximum speed ^{Note 2} (mm/sec)	1500	1000	1500
Moving range (mm)	330	150	100
Cycle time (sec)	0.57 ^{Note 3} , 0.78 ^{Note 4}		
Maximum payload (kg)	3		
Robot cable length (m)	Standard: 3.5 Option: 5,10		
Weight (kg)	32		

Note 1. Positioning repeatability precision in a single swing when residual vibration is stabilized (variable depending on the load and stroke).
 Note 2. When the moving stroke is short, the maximum speed may not be reached.
 Note 3. Reciprocating time in vertical direction (50mm) and longitudinal direction (150mm) with the arch amount of 50 (when executing rough-positioning arch motion with 1kg load).
 Note 4. Reciprocating time in vertical direction (25mm) and longitudinal direction (300mm) with the arch amount of 25 (when executing rough-positioning arch motion with 1kg load).

Controller

Controller	Power consumption (VA)	Operating method
RCX340 RCX240S	700	Programming / I/O point trace / Remote command / Operation using RS-232C communication

YP330X

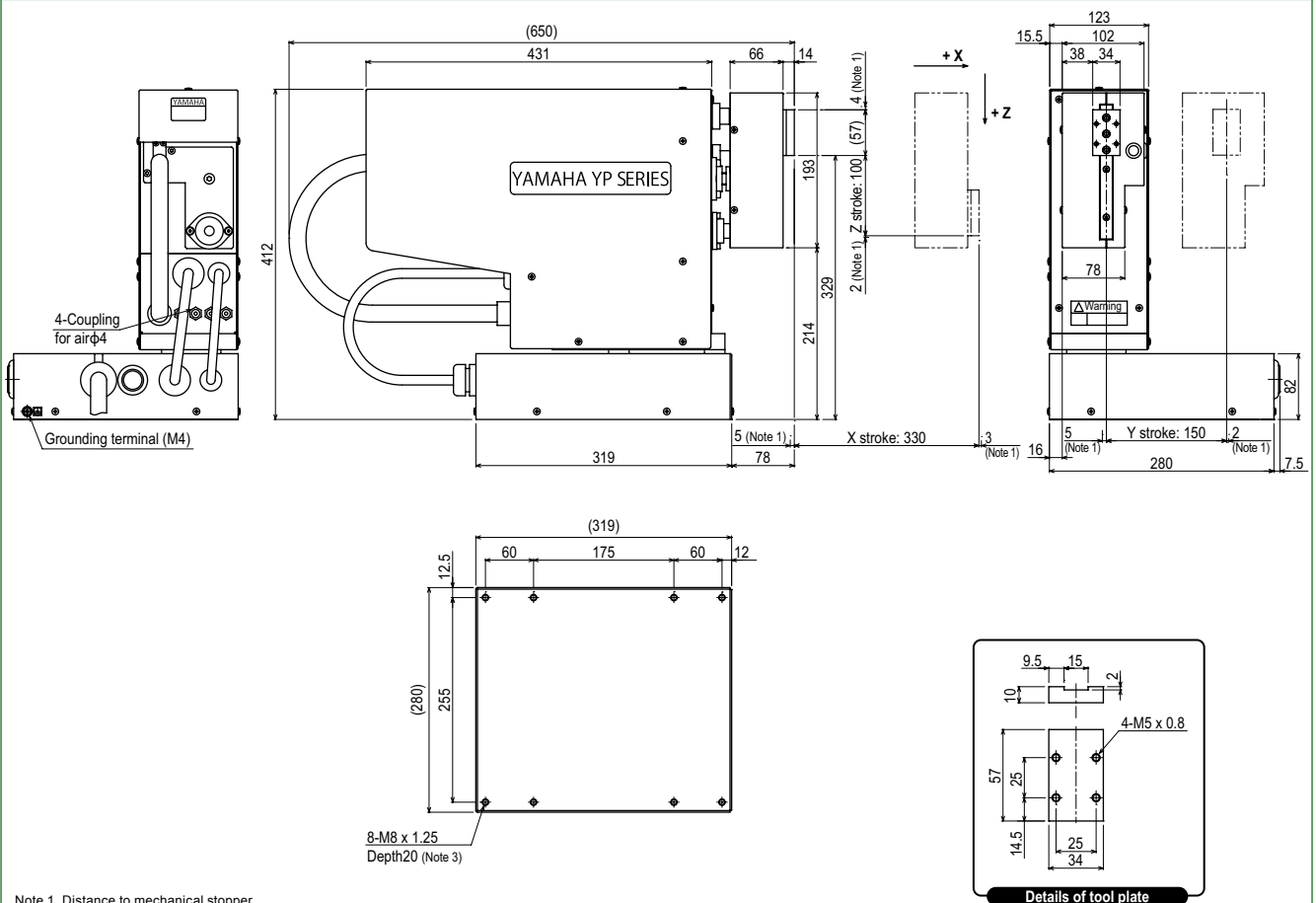

Note 1. Distance to mechanical stopper.
 Note 2. Return-to-origin on the YP330X is by absolute reset. So the origin position must be set the first time (making initial settings) but after that is not required.
 Note 3. Do not use bolts longer than 20mm (robot bottom plate thickness).

Controller

RCX340 ▶ 542 RCX240S ▶ 532

Articulated robots
YA

Linear conveyor modules
LCM100

Compact single-axis robots
TRANSEVO

Single-axis robots
FLIP-X

Linear motor single-axis robots
PHASER

Cartesian robots
XX-X

SCARA robots
YK-X

Pick & place robots
YP-X

CLEAN

CONTROLLER INFORMATION

2-axes

3-axes

4-axes

YP340X 4 axes

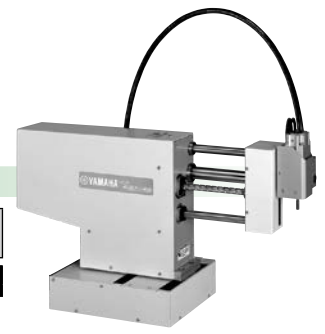

Ordering method

YP340X

Model

Cable length
3L: 3.5m
5L: 5m
10L: 10m

RCX340-4

Controller /
Number of controllable axes

Safety
standard

Option A
(OP.A)

Option B
(OP.B)

Option C
(OP.C)

Option D
(OP.D)

Option E
(OP.E)

Absolute
battery

Specify various controller setting items. RCX340 ▶ **P.542**

RCX240S

Controller

CE Marking

Expansion I/O

Network option

iVY System

Gripper

Battery

Specify various controller setting items. RCX240/RCX240S ▶ **P.532**

Specifications

	X axis	Y axis	Z axis	R axis
AC servo motor output (W)	200	200	200	60
Repeatability ^{Note 1} (XYZ: mm)(R: °)	+/-0.02	+/-0.02	+/-0.05	+/-0.1
Drive system	Ball screw (C7 class)	Ball screw (C7 class)	Timing belt	Ball Reducer
Deceleration ratio (mm)	Equivalent to lead 20	Equivalent to lead 20	Equivalent to lead 25	1/18
Maximum speed ^{Note 2} (XYZ: mm/sec) (R: °/sec)	1500	1000	1500	1000
Moving range (XYZ: mm) (R: °)	330	150	100	+/-180
Cycle time (sec)	0.67 ^{Note 3} , 0.87 ^{Note 4}			
Maximum payload (kg)	1			
R-axis allowable moment inertia (kgm ² [kgfcm ²])	0.00098 [0.01]			
Robot cable length (m)	Standard: 3.5 Option: 5,10			
Weight (kg)	34			

Note 1. Positioning repeatability precision in a single swing when residual vibration is stabilized (variable depending on the load and stroke).
 Note 2. When the moving stroke is short, the maximum speed may not be reached.
 Note 3. Reciprocating time in vertical direction (50mm) and longitudinal direction (150mm) with the arch amount of 50 (when executing rough-positioning arch motion with 1kg load).
 Note 4. Reciprocating time in vertical direction (25mm) and longitudinal direction (300mm) with the arch amount of 25 (when executing rough-positioning arch motion with 1kg load).

Controller

Controller	Power consumption (VA)	Operating method
RCX340 RCX240S	800	Programming / I/O point trace / Remote command / Operation using RS-232C communication

YP340X

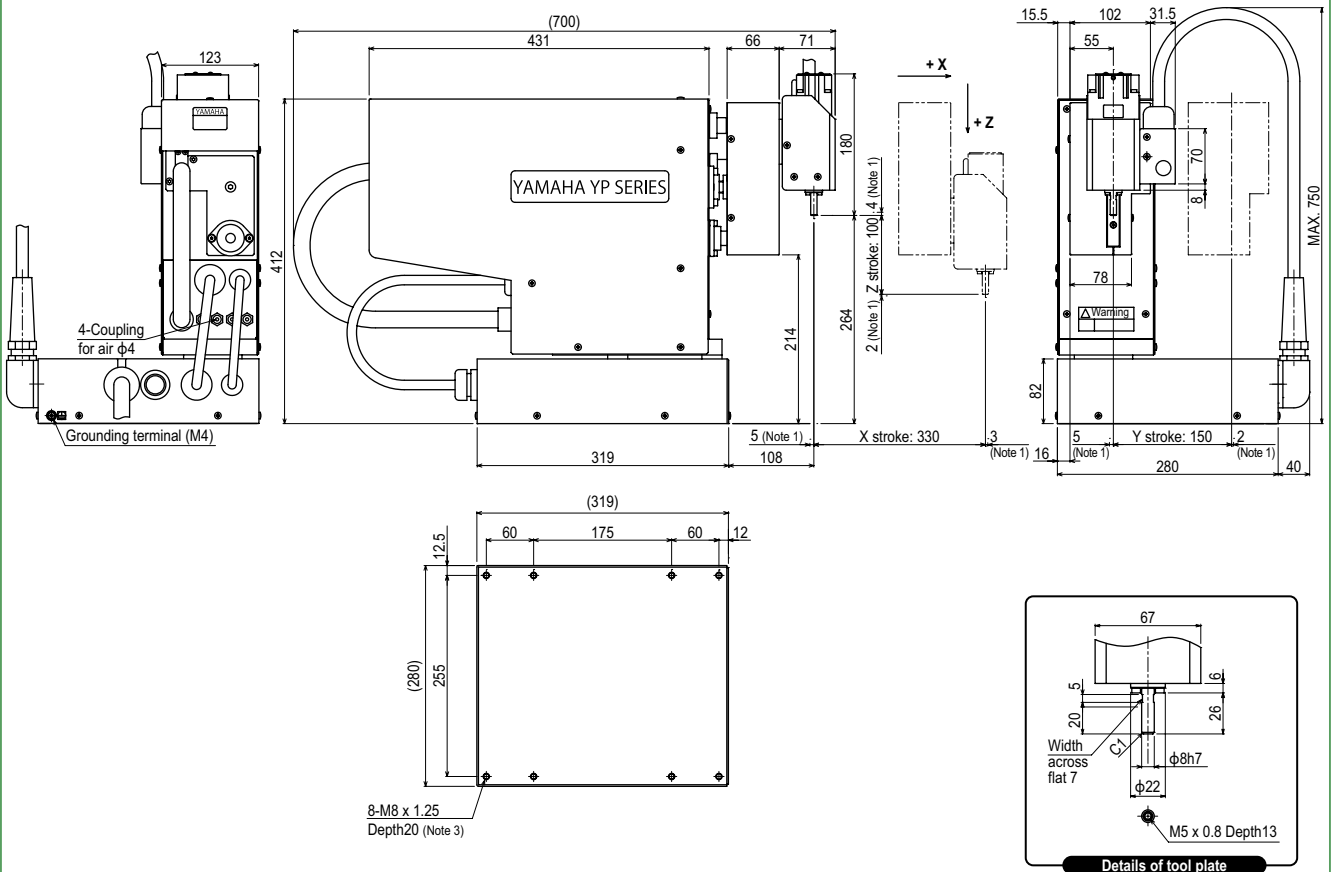

Note 1. Distance to mechanical stopper.
 Note 2. Return-to-origin on the YP340X is by absolute reset. So the origin position must be set the first time (making initial settings) but after that is not required.
 Note 3. Do not use bolts longer than 20mm (robot bottom plate thickness).