

YAMAHA  
**ROBOT**



Estratto Catalogo Yamaha  
**Robot SCARA (Serie YK)**

## YK-X Series

Product Lineup

YK-TW	Omni directional model
YK-XG/YK-X	Completely beltless model <sup>Note</sup>
YK-XR	Low cost high performance model
YK-XGS	Wall mount/inverse model
YK-XGP	Dust-proof & drip-proof model

Note. Except for YK1200X

# SCARA ROBOTS

Arm length of 120 mm to 1200 mm, full-selection of lineup is top in the world. Completely beltless structure pursues the features of SCARA robots to their utmost limits.



**NEW** Low cost high performance model  
YK400XR

### History of 30 years

The first YAMAHA robots were SCARA robots. Since the first SCARA robot called "CAME" was produced in 1979, some 30 years of SCARA robot innovations have continually appeared. These SCARA robots have undergone countless modifications in an ever changing marketplace and amassed a hefty record of successful products making them an essential part of the YAMAHA robot lineup.



1979  
<YK7000>

# Comprehensive line of YAMAHA SCARA robots

## Orbit type

P.338

- Arm length 500 mm
- Maximum payload 4 kg



YK500TW

## Extra small type

P.342

- Arm length 120 mm to 220 mm
- Maximum payload 1 kg



YK120XG/YK150XG/YK180XG



YK180X/YK220X

## Small type

P.347

- Arm length 250 mm to 400 mm
- Maximum payload 5 kg

Low cost high performance model  
YK400XR

NEW



YK400XR



YK250XG/YK350XG/YK400XG

## Medium type

P.354

- Arm length 500 mm to 600 mm
- Maximum payload 5 kg to 20 kg



YK500XGL



YK500XG



YK600XGL



YK600XG/XGH

## Large type

P.361

- Arm length 700 mm to 1200 mm
- Maximum payload 20 kg to 50 kg



YK700XG



YK800XG



YK900XG



YK1000XG



YK1200X

## Wall mount/inverse model

P.367

YK300XGS to YK1000XGS



Wall mount type



Inverse type

- Wall mount type

Type where the robot body is installed in the wall.

- Inverse type

Type where the wall-mount type is installed upside down.

## Dust-proof & drip-proof model

P.377



YK250XGP/YK350XGP/YK400XGP  
YK500XGLP/YK600XGLP



YK500XGP to YK1000XGP

Plays active part in the working environment with a large amount of water or dust (protection class equivalent to IP65).

- Please consult YAMAHA for anti-droplet protection for fluids other than water.

## YK-TW Orbit type

### YK-TW POINT 1

#### Accessible to 360 °-whole area under equipment

360 °-whole area under the equipment is covered by the hanging installation and wide arm turning angle. The plane working envelope is improved approx. 120 % when compared to YAMAHA's conventional model with an arm length of 500 mm. There is no dead space at the center of the working envelope. This ensures an operation range of  $\phi$  1,000 mm x 130 mm. As the working envelope is cylindrical, the pallet or conveyor installation direction is not restricted and the flexibility of the system design is improved.

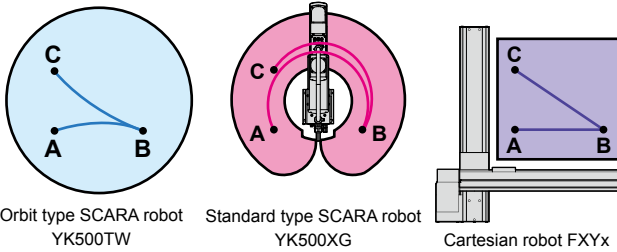
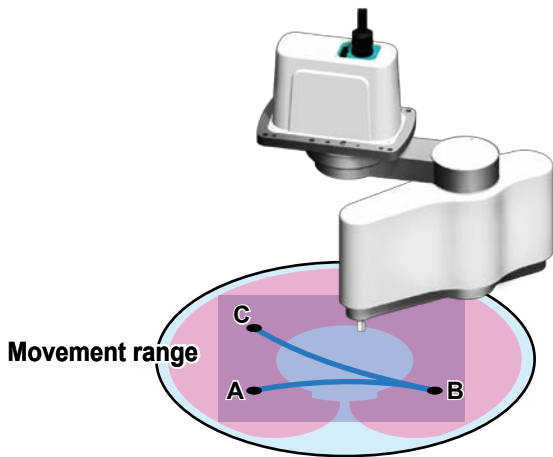

#### Comparison of robot tact times

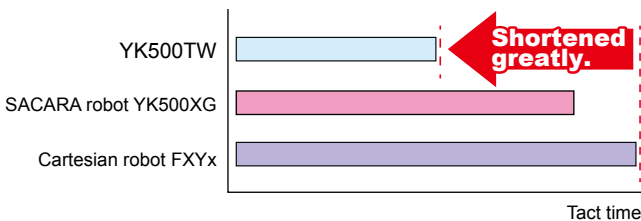

### YK-TW POINT 2

#### Low overall height makes the equipment compact.

The overall height is as low as 392 mm. This can lower the center of gravity of the overall equipment. Therefore, the equipment can be downsized without needing any rigid frame. As the production equipment is made compact, this shortens a period of time necessary for the workpiece transfer.

### YK-TW POINT 3

#### Tact is shortened by high-speed movement.

Use of a horizontal articulated structure, in which the Y-axis (2nd arm) can pass under the X-axis (1st arm) makes it possible to move between the points through the optimum route at a high speed. This greatly contributes to shortening of the tact time in the light load transfer process, such as electrical or food industry.

#### Standard cycle time is 0.29 sec.

When performing a reciprocation operation with a load of 1 kg, a horizontal movement of 300 mm, and a vertical movement of 25 mm, the standard cycle time is shortened about 36 % when compared to YAMAHA's conventional model.

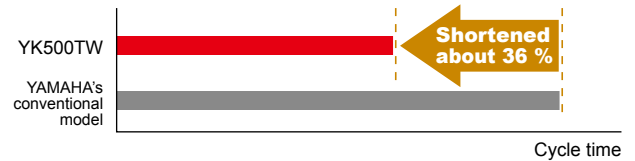

### YK-TW POINT 4

#### High speed and highly accurate positioning by high mechanical rigidity

**Repeated positioning accuracy  $\pm 0.015$  mm**

High accuracy and high load transferable by parallel link robot

The internal structure of the robot was reviewed strictly to optimize the weight balance. Additionally, a motor tuned optimally for the lightweight and highly rigid arm was incorporated to achieve the high speed and highly accurate positioning.

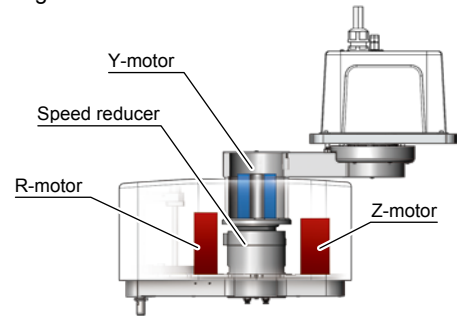

#### Hollow structure is used.

Y-motor and speed reducer have a hollow structure, the harnesses can be stored inside the arm.

360 ° Rotation

#### Heavy components are arranged at the center.

R-motor and Z-motor are arranged on the left and right, respectively to optimize the weight balance.

Inertia is reduced to make the high-speed operation possible

### YK-TW POINT 5

#### Resolver is used for position detector.

Resolver is a magnetic position detector. The resolver features a simple structure without using electronic components and optical elements, and less potential failure factors when compared to general optical encoders. The resolver has high environment resistance and low failure ratio, and is used in a wide variety of fields aiming at reliability such as automobile or aircraft industry.



## YK-XG Completely beltless type

# Integral structure designed for optimal operation

Note. The following shows an example of YK500XG.

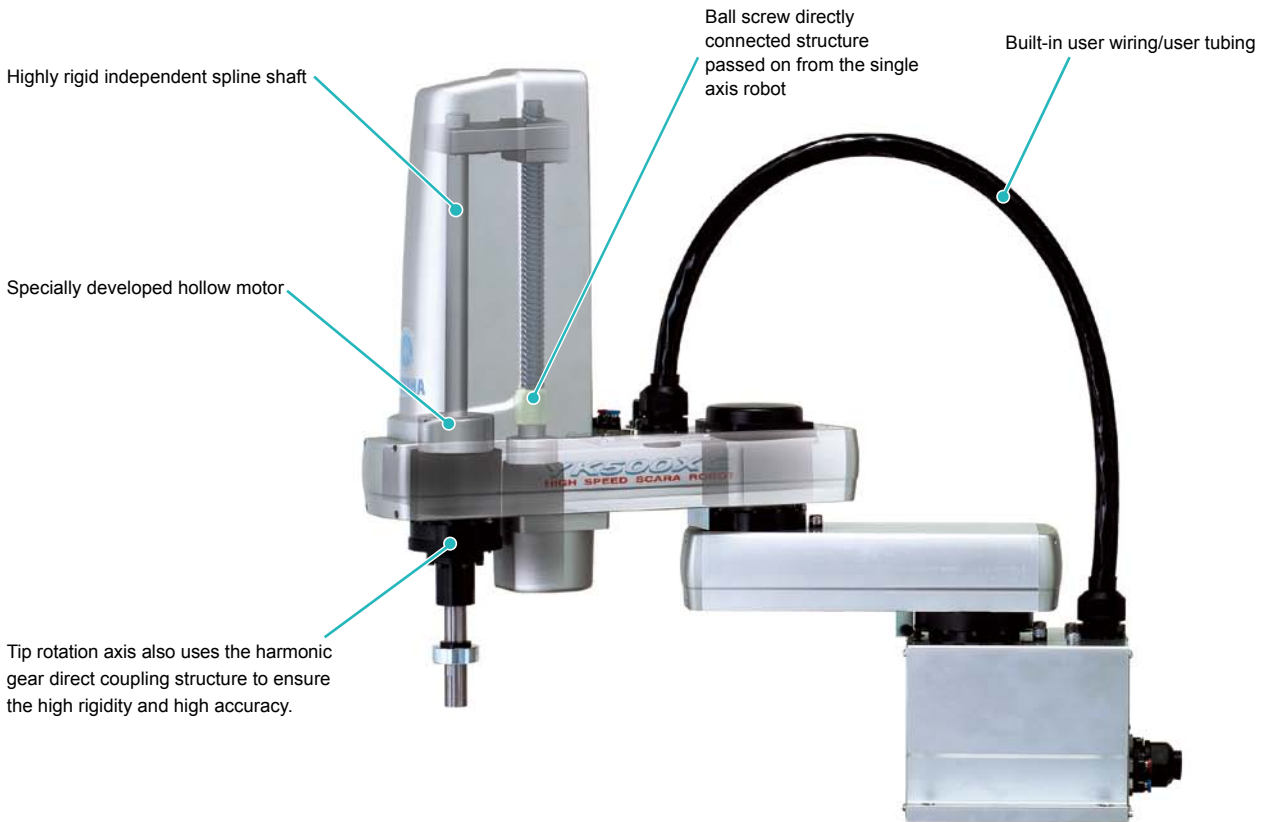

### YK-XG POINT 1

## Completely beltless structure

A completely beltless structure was achieved using a ZR-axis direct coupling structure. This completely beltless structure greatly reduces waste motion. This structure also maintains high accuracy for an extended period of time. Additionally, this structure ensures maintenance-free operation for an extended period of time without worrying about belt breakage, elongation, or secular deterioration (except for Orbit type and large type).

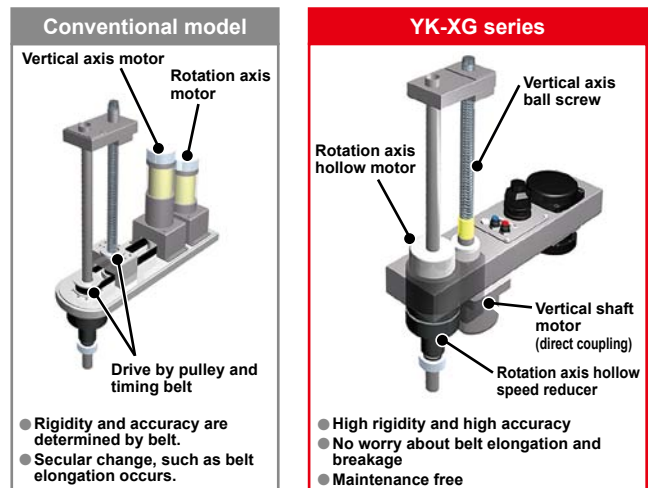

### YK-XG POINT 2

## High speed

The standard cycle time is fast. Additionally, YAMAHA also places special emphasis on the tact time in the practical working area. The speed reduction ratio or maximum motor RPM was reviewed to greatly improve the maximum speed. This contributes to improvement of the tact time.

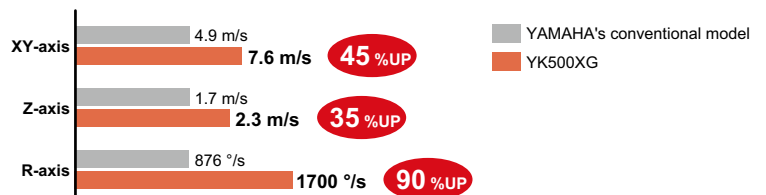

YK-XG POINT 3

Resolver is used for position detector.



As the resolver uses a simple and rigid structure without using electronic components and optical elements, it features high environment resistance and low failure ratio. Detection problems due to electronic component breakdown, dew condensation on or oil sticking to the disk that may occur in optical encoders do not occur in the resolver due to its structure. Additionally, as **the absolute specifications and incremental specifications use the same mechanical specifications and common controller**, the specifications can be changed only by setting parameters. Furthermore, even when the absolute battery is consumed completely, the robot can still operate as the incremental specifications. So, even if a trouble occurs, the line stop is not needed to ensure the safe production line. The backup circuit has been completely renovated and now has a backup period of one year in the non-energizing state.

Note. The resolver has a simple structure without using electronic components. So, the resolver is highly resistant to low and high temperatures, impacts, electrical noise, dust particles, and oil, etc., and is used in automobiles, trains, and aircrafts that particularly require the reliability.

**Optical encoder**



- Optical type
- Electronic components are required and structure is complicated.
- Electronic component malfunction, or dew condensation on or oily content sticking to disk may occur easily.

▼

**Detection failure**

**Resolver**



- Magnetic type
- Simple structure only with iron core and winding has less potential failure factors.
- Immune to shock and electric noise.

▼

**High reliability**

YK-XG POINT 4

Excellent maintenance ability

The covers of YAMAHA SCARA robot YK-XG series can be removed forward or upward. The cover is separated from the cable, so the maintenance work is easy. Additionally, the grease replacement of the harmonic gear needs many steps to disassemble the gear and may cause positional deviation. However, since the harmonic gear of the YAMAHA SCARA robot uses long-life grease, the grease replacement is not needed.

YK-XG POINT 5

Surprising R-axis tolerable moment of inertia

The SCARA robot performance cannot be expressed only by the standard cycle time. In actual operating environments, there are various workpieces, such as heavy workpiece or workpiece with large offset. At this time, since the robot with low R-axis tolerable moment of inertia needs to decrease the speed during operation, the cycle time decreases greatly. All YAMAHA SCARA robot YK-XG types have the tip rotation axis directly coupled to the speed reducer. Since the R-axis tolerable moment of inertia is very high when compared to a general structure in which the moment of inertia is transmitted by a belt after decelerating, the robot can operate at a high speed even with workpieces that have been offset.

**YK120XG**  
(R-axis tolerable moment of inertia: 0.1 kgfcm<sup>2</sup>)

When the tip load weight is 1 kg, it is possible to operate at **approx. 100 mm** offset.

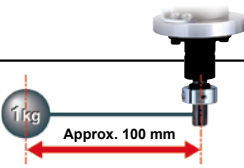

R-axis tolerable moment of inertia: Comparison between YK120XG and other company's model

When the offset from the R-axis to the center of gravity of the load is large, the inertia becomes large and the acceleration during operation is restricted. The R-axis tolerable moment of inertia of YAMAHA XG series is exceedingly large when compared to other company's SCARA robots in the similar class, so it can operate at a high speed even in the offset state.

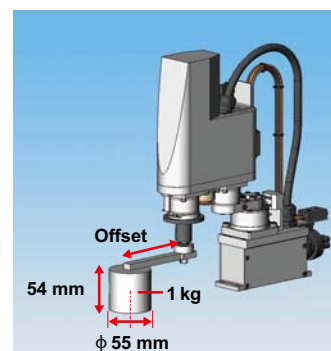

When the load weight is 1 kg (refer to the right in the figure.)

Offset (mm)	Inertia (kgfcm <sup>2</sup> )	Operation	
		YK120XG	Company A
0	0.0039	○	○
45	0.025	○	×
97	0.1	○	×

○: Operable    ×: Out of catalog value tolerance range

◆ R-axis tolerable moment of inertia: YK120XG ..... 0.1 kgfcm<sup>2</sup>  
Company A ..... 0.0039 kgfcm<sup>2</sup>

## YK-XG POINT 6

### Compact

As the cable layout is changed, the cable height becomes lower than the main body cover. Additionally, use of extruded material base and motor with low overall height achieves the lowest overall height in the same class.

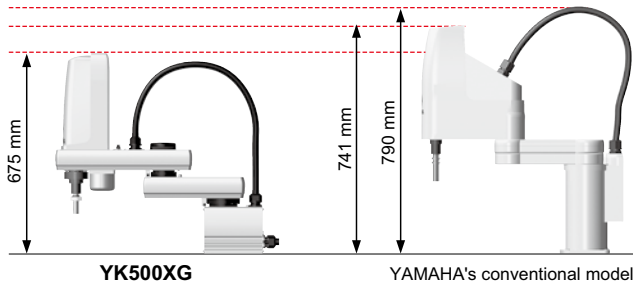

## YK-XG POINT 7

### Hollow shaft and tool flange options are selectable.

Hollow shaft that allows easy wiring to the tip tool and tool flange for tool mounting are provided as options.



Hollow shaft option convenient for routing of air tubes and harness wires

Note. YK250XG to YK400XG  
YK500XGL/YK600XGL



Tool flange option for easy mounting of a tool to the tip

Note. YK250XG to YK1000XG

## YK-XG POINT 8

### Zone control (= Optimal acceleration/deceleration automatic setting) function

In the SCARA robot, the load applied to the motor and speed reducer in the arm folded state greatly differs from that in the arm extended state. YAMAHA SCARA robot **automatically selects** optimal acceleration and deceleration from the arm postures at operation start and operation end. Therefore, the robot does not exceed the tolerance value of **the motor peak torque** or **speed reducer allowable peak torque** only by entering the initial payload. So, full power can be extracted from the motor whenever needed and high acceleration/deceleration are maintained.

#### For X-axis of YK500XG

The torque in the arm folded state is 5 or more times different from that in the arm extended state.

**This may greatly affect the service life, vibration during operation, and controllability.**

If the motor torque exceeds the peak value

→ **This may adversely affect the controllability and mechanical vibration, etc.**

If the torque exceeds the tolerable peak torque value of the speed reducer

→ **This may cause early breakage or shorten the service life extremely.**

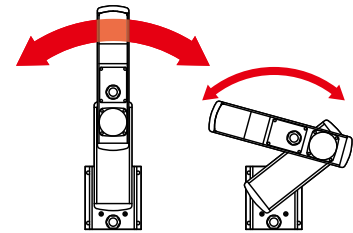

## YK-XG POINT 9

### Low price models with the arm length 500 mm/600 mm specifications are also added to the product lineup.

The customers require to use SCARA robots at a more affordable price. Models YK500XGL/YK600XGL were developed to meet these customer's requests. About 30 %-cost reduction was achieved when compared to the conventional models YK500XG/600XG.

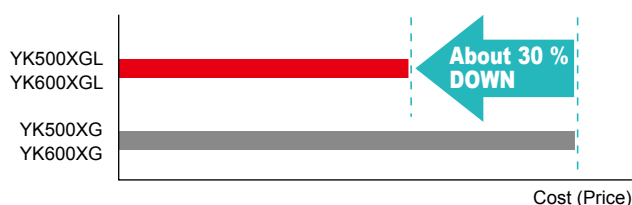

NEW

## YK-XR Low cost high performance model YK400XR

### YK-XR POINT 1

#### Shortest cycle time in this class

A standard cycle time of 0.45 sec. is achieved by drawing out the robot performance to its maximum level.

### YK-XR POINT 2

#### Superior cost performance

Most economical price in YAMAHA's similar robot class without sacrificing its existing features.

### YK-XR POINT 3

#### With versatile and high performance controller RCX340.

Combination of YK400XR robot and new RCX340 controller enable operation up to 16 axes with simple easy networking.

## YK-XGS Wall mount/inverse model

#### Hanging type is renewed. Completely beltless structure and high rigidity

As the conventional hanging type is changed to the wall mount type, the flexibility of the system design is improved. The production equipment can be downsized. Additionally, as an inverse type that allows upward operation is also added to the product lineup, the flexibility of the working direction is widened. Furthermore, use of a completely beltless structure achieves a maximum payload of 20 kg and a R-axis tolerable moment of inertia of 1 kgm<sup>2</sup>Note that are the top in the class. A large hand can also be installed. So, this robot is suitable for heavy load work.

Note. YK700XGS to YK1000XGS



## YK-XGP Dust-proof & drip-proof model

#### Up/down bellows structure improves the dust-proof and drip-proof performance.

The dust-proof and drip-proof type that can be operated even in a work environment where water or particle dust scatters was renewed to a completely beltless structure. The belt does not deteriorate and poor environment resistance is improved. Additionally, an up/down bellows structure is used to improve the dust-proof and drip-proof performance.

Note. YK250XGP to YK600XGLP



### Protection class equivalent to IP65 (IEC60529)

Seals are added to the joints to maintain the dust-proof and drip-proof performance without air purging. The robot conforms to the protection class equivalent to IP65 (IEC60529).

**IP 65** - Class of protection against invasion of water: 5  
 Water injected from any direction does not affect adversely.  
 The standard pressure of the injected water is 30 KPa (30 KN/m<sup>2</sup>, 0.3 kgf/cm).  
 The injection speed is 12.5 liters/min. and the injection time is 3 min.  
 Note. The water injected under conditions exceeding those shown above may enter the unit.  
**Class of protection against solid objects: 6**  
 No invasion of particle dust.

### Dust-proof and drip-proof connector for user wiring is provided as standard.



YK250XGP to 600XGLP (arm part)



YK250XGP to 600XGLP (base part)



Model/Type		Model	Arm length (mm)	Maximum payload (kg)	Standard cycle time (sec.)	Page
Omni directional model		<b>NEW</b> YK350TW	400	5.0	0.32 (RCX340) / 0.38 (RCX240)	P.338
		YK500TW	500	5.0 (RCX340) / 4.0 (RCX240) <sup>Note 3</sup>	0.29	P.340
Completely beltless model	Micro-mini type (Tiny)	YK120XG	120	1.0	0.33	P.342
		YK150XG	150			P.343
		YK180XG	180			P.344
		YK180X	180			P.345
		YK220X	220			P.346
	Small type	YK250XG	250	5.0 (4.0) <sup>Note 2</sup>	0.49	P.347
		YK350XG	350			P.349
		<b>NEW</b> YK400XG	400			P.351
Low cost high performance model	YK400XR	400	3.0 (2.0) <sup>Note 2</sup>	0.45	P.353	
Completely beltless model	Medium type	YK500XGL	500	5.0 (4.0) <sup>Note 2</sup>	0.59	P.354
		YK500XG	500	10.0	0.45	P.356
		YK600XGL	600	5.0 (4.0) <sup>Note 2</sup>	0.63	P.357
		YK600XG	600	10.0	0.46	P.359
		YK600XGH	600	20.0	0.47	P.360
	Large type	<b>NEW</b> YK700XGL	800	10.0	0.50	P.361
		YK700XG	700	20.0	0.42	P.362
		YK800XG	800		0.48	P.363
		YK900XG	900		0.49	P.364
		YK1000XG	1000		0.49	P.365
-	YK1200X	1200	50.0		0.91	P.366
Wall mount/inverse model		YK300XGS <sup>Note 1</sup>	300	5.0 (4.0) <sup>Note 2</sup>	0.49	P.367
		YK400XGS <sup>Note 1</sup>	400			P.369
		YK500XGS	500	10.0	0.45	P.371
		YK600XGS	600		0.46	P.372
		YK700XGS	700	20.0	0.42	P.373
		YK800XGS	800		0.48	P.374
		YK900XGS	900		0.49	P.375
		YK1000XGS	1000		0.6	P.376
Dust-proof & drip-proof model		YK250XGP	250	5.0	0.49	P.377
		YK350XGP	350			P.379
		YK400XGP	400			P.381
		YK500XGLP	500	4.0	0.74	P.383
		YK500XGP	500	8.0	0.55	P.385
		YK600XGLP	600	4.0	0.74	P.386
		YK600XGP	600	8.0	0.56	P.388
		YK600XGHP	600	18.0	0.57	P.389
		YK700XGP	700		0.52	P.390
		YK800XGP	800		0.58	P.391
		YK900XGP	900		0.59	P.392
		YK1000XGP	1000		0.59	P.393

Note 1. The YK300XGS and YK400XGS are custom-order products. For details about the delivery time, please contact YAMAHA.

Note 2. For the option specifications (tool flange mount type and user wiring/tubing through spline type), the maximum payload becomes the value in ( ).

Note 3. For the option specifications (tool flange mount type), the maximum payload becomes 4 kg (RCX340) or 3 kg (RCX240).



# SCARA ROBOTS

# YK-X

## SERIES

APPLICATION	Linear conveyor modules LCM100
TRANSEKVO	Compact single-axis robots
FLIP-X	Single-axis robots
PHASER	Linear motor single-axis robots
XY-X	Cartesian robots
YK-X	SCARA robots
YP-X	Pick & place robots
CLEAN	
CONTROLLER	
INFORMATION	
Orbit / Tiny type	
Small / Medium type	
Large type	
Wall-mount / Inverse type	
Dust-proof & drip-proof type	

## CONTENTS

<ul style="list-style-type: none"> <li>■ <b>YK-X SPECIFICATION SHEET</b>... 336</li> <li>■ <b>Robot ordering method description</b> ..... 337</li> <li>■ <b>Robot ordering method terminology</b> ..... 337</li> </ul>	<ul style="list-style-type: none"> <li> <ul style="list-style-type: none"> <li><b>LARGE TYPE</b></li> <li>YK700XGL .....361</li> <li>YK700XG ..... 362</li> <li>YK800XG ..... 363</li> <li>YK900XG ..... 364</li> <li>YK1000XG..... 365</li> <li>YK1200X..... 366</li> </ul> </li> <li> <ul style="list-style-type: none"> <li><b>WALL-MOUNT / INVERSE TYPE</b></li> <li>YK300XGS ..... 367</li> <li>YK400XGS ..... 369</li> <li>YK500XGS .....371</li> <li>YK600XGS .....372</li> <li>YK700XGS .....373</li> <li>YK800XGS .....374</li> <li>YK900XGS .....375</li> <li>YK1000XGS .....376</li> </ul> </li> <li> <ul style="list-style-type: none"> <li><b>DUST-PROOF &amp; DRIP-PROOF TYPE</b></li> <li>YK250XGP .....377</li> <li>YK350XGP .....379</li> <li>YK400XGP .....381</li> <li>YK500XGLP ..... 383</li> <li>YK500XGP ..... 385</li> <li>YK600XGLP ..... 386</li> <li>YK600XGP ..... 388</li> <li>YK600XGHP ..... 389</li> <li>YK700XGP ..... 390</li> </ul> </li> </ul>	<ul style="list-style-type: none"> <li>YK800XGP .....391</li> <li>YK900XGP ..... 392</li> <li>YK1000XGP ..... 393</li> </ul>
<ul style="list-style-type: none"> <li><b>ORBIT TYPE</b></li> <li>YK350TW ..... 338</li> <li>YK500TW ..... 340</li> </ul>		
<ul style="list-style-type: none"> <li><b>TINY TYPE</b></li> <li>YK120XG ..... 342</li> <li>YK150XG ..... 343</li> <li>YK180XG ..... 344</li> <li>YK180X ..... 345</li> <li>YK220X ..... 346</li> </ul>		
<ul style="list-style-type: none"> <li><b>SMALL TYPE</b></li> <li>YK250XG .....347</li> <li>YK350XG ..... 349</li> <li>YK400XG .....351</li> <li>YK400XR ..... 353</li> </ul>		
<ul style="list-style-type: none"> <li><b>MEDIUM TYPE</b></li> <li>YK500XGL ..... 354</li> <li>YK500XG ..... 356</li> <li>YK600XGL .....357</li> <li>YK600XG ..... 359</li> <li>YK600XGH ..... 360</li> </ul>		

# YK-X SPECIFICATION SHEET

Linear conveyor modules  
LCM100

Compact single-axis robots  
TRANSEVO

Single-axis robots  
FLIP-X

Linear motor single-axis robots  
PHASER

Cartesian robots  
XY-X

SCARA robots  
YK-X

Pick & place robots  
YP-X

CLEAN

CONTROLLER INFORMATION

Orbit/Tiny type

Small / Medium type

Large type

Wall-mount / Inverse type

Dust-proof & drip-proof type

Type	Model	Arm length (mm) and XY axis resultant maximum speed (m/s)														Standard cycle time (sec) <small>Note 1</small>	Maximum payload (kg)	R-axis tolerable moment of inertia (kgm <sup>2</sup> ) <small>0.005 (Rated) 0.05 (Maximum)</small>	Completely beltless structure <small>Note 2</small>	R-axis harmonic drive <small>Note 3</small>	Detailed info page			
		120	150	180	220	250	300	350	400	500	600	700	800	900	1000							1200		
Orbit type	YK350TW	5.6														0.32 (RCX340) 0.38 (RCX240)	5	0.005 (Rated) 0.05 (Maximum)			<a href="#">P.338</a>			
	YK500TW	6.8														0.29	5	0.005 (Rated) 0.05 (Maximum)			<a href="#">P.340</a>			
Standard	Tiny type	YK120XG	3.3														0.33	1	0.01	●	●	<a href="#">P.342</a>		
		YK150XG	3.4														0.33	1	0.01	●	●	<a href="#">P.343</a>		
		YK180XG	3.3														0.33	1	0.01	●	●	<a href="#">P.344</a>		
		YK180X	3.3														0.39	1	0.01	●	●	<a href="#">P.345</a>		
		YK220X	3.4														0.42	1	0.01	●	●	<a href="#">P.346</a>		
	Small type	YK250XG	4.5														0.49	5	0.05	●	●	<a href="#">P.347</a>		
		YK350XG	5.6														0.49	5	0.05	●	●	<a href="#">P.349</a>		
		YK400XG	6.1														0.49	5	0.05	●	●	<a href="#">P.351</a>		
		YK400XR	6														0.45	3	0.05			<a href="#">P.353</a>		
		YK500XGL	5.1															0.59	5	0.05	●	●	<a href="#">P.354</a>	
Medium type	YK500XG	7.6															0.45	10	0.30	●	●	<a href="#">P.356</a>		
	YK600XGL	4.9																	0.63	5	0.05	●	●	<a href="#">P.357</a>
	YK600XG	8.4																	0.46	10	0.30	●	●	<a href="#">P.359</a>
	YK600XGH	7.7																	0.47	20	1.0	●	●	<a href="#">P.360</a>
Large type	YK700XGL	9.2														0.50	10	0.30	●	●	<a href="#">P.361</a>			
	YK700XG	8.4																	0.42	20	1.0	●	●	<a href="#">P.362</a>
	YK800XG	9.2														0.48	20	1.0	●	●	<a href="#">P.363</a>			
	YK900XG	9.9														0.49	20	1.0	●	●	<a href="#">P.364</a>			
	YK1000XG	10.6														0.49	20	1.0	●	●	<a href="#">P.365</a>			
	YK1200X	7.4														0.91	50	2.45		●	<a href="#">P.366</a>			
Wall-mount / Inverse type	YK300XGS	4.4														0.49	5	0.05	●	●	<a href="#">P.367</a>			
	YK400XGS	6.1														0.49	5	0.05	●	●	<a href="#">P.369</a>			
	YK500XGS	7.6														0.45	10	0.3	●	●	<a href="#">P.371</a>			
	YK600XGS	8.4															0.46	10	0.3	●	●	<a href="#">P.372</a>		
	YK700XGS	8.4																	0.42	20	1.0	●	●	<a href="#">P.373</a>
	YK800XGS	9.2														0.48	20	1.0	●	●	<a href="#">P.374</a>			
	YK900XGS	9.9														0.49	20	1.0	●	●	<a href="#">P.375</a>			
	YK1000XGS	10.6														0.49	20	1.0	●	●	<a href="#">P.376</a>			
	Dust-proof & drip-proof type	YK250XGP	4.5														0.57	4	0.05	●	●	<a href="#">P.377</a>		
YK350XGP		5.6														0.57	4	0.05	●	●	<a href="#">P.379</a>			
YK400XGP		6.1														0.57	4	0.05	●	●	<a href="#">P.381</a>			
YK500XGLP		5.1															0.74	4	0.05	●	●	<a href="#">P.383</a>		
YK500XGP		7.6															0.55	8	0.3	●	●	<a href="#">P.385</a>		
YK600XGLP		4.9																	0.74	4	0.05	●	●	<a href="#">P.386</a>
YK600XGP		8.4																	0.56	8	0.3	●	●	<a href="#">P.388</a>
YK600XGHP		7.7																	0.57	18	1.0	●	●	<a href="#">P.389</a>
YK700XGP		8.4														0.52	18	1.0	●	●	<a href="#">P.390</a>			
YK800XGP		9.2														0.58	18	1.0	●	●	<a href="#">P.391</a>			
YK900XGP		9.9														0.59	18	1.0	●	●	<a href="#">P.392</a>			
YK1000XGP		10.6														0.59	18	1.0	●	●	<a href="#">P.393</a>			

Note 1. The standard cycle time is measured under the following conditions.  
 • During back and forth movement 25mm vertically and 100mm horizontally (TINY)  
 • During back and forth movement 25mm vertically and 300mm horizontally (small type / medium type / large type)  
 Note 2. Maintains high accuracy over long periods because the beltless structure drastically cuts down on wasted motion.  
 Operation is also nearly maintenance-free for long periods with no worries about belt breakage, stretching or deterioration over time.  
 Note 3. "Harmonic" and "Harmonic drive" are the registered trademarks of Harmonic Drive Systems Inc.

# Robot ordering method description

In the order format for the YAMAHA SCARA robots YK-X series, the notation (letters/numbers) for the mechanical section is shown linked to the controller section notation.

## [Example]

### ● Mechanical ▶ YK250XG

- Z-axis stroke ▷ 150mm
- Tool flange ▷ With tool flange
- Hollow shaft ▷ With hollow shaft
- Cable length ▷ 3.5m

### ● Controller ▶ RCX240S

### ● Ordering method

# YK250XG-150-F-S-3L-RCX240S

Mechanical section

Controller section

To find detailed controller information see the controller page. **RCX240 ▶ P.495**, **RCX340 ▶ P.508**

① Model	② Z-axis stroke		③ Tool flange		④ Hollow shaft		⑤ Cable		⑥ Controller
YK***	50	50mm	No entry	None	No entry	None	2L	2m	RCX240
	100	100mm	F	With tool flange	S	With hollow shaft	3L	3.5m	RCX240S
	150	150mm					5L	5m	RCX340
	200	200mm					10L	10m	
	300	300mm							
	400	400mm							

Note 1. Available only for the master.

# Robot ordering method terminology

① <b>Model</b>	Enter the robot unit model.
② <b>Z-axis stroke</b>	Select the Z axis stroke. The stroke varies with the model you select so see that model's page to confirm the specifications.
③ <b>Tool flange</b>	Tool flange option for easy mounting of a tool to the tip. <b>No entry:</b> None <b>F:</b> With tool flange
④ <b>Hollow shaft</b>	Hollow shaft option for easy routing of air tubes and harness wires. <b>No entry:</b> None <b>S:</b> With hollow shaft
⑤ <b>Cable</b>	Select the length of the robot cable connecting the robot and controller. <b>2L:</b> 2m <sup>(Note 1)</sup> <b>3L:</b> 3.5m <b>5L:</b> 5m <b>10L:</b> 10m <small>Note 1. Only selectable for YK120XG, YK150XG, YK180XG.</small>
⑥ <b>Controller</b>	Select either the RCX240 (RCX240S) or RCX340.

APPLICATION

Linear conveyor modules  
LCM100

Compact single-axis robots  
TRANSEVO

Single-axis robots  
FLIP-X

Linear motor single-axis robots  
PHASER

Cartesian robots  
XY-X

SCARA robots  
YK-X

Pick & place robots  
YP-X

CLEAN

CONTROLLER

INFORMATION

Orbit / Turn type

Small / Medium type

Large type

Wall-mount / Inverse type

Dust-proof & drip-proof type

# YK350TW

Orbit type



- Arm length 350mm
- Maximum payload 5kg

## Ordering method

**YK350TW-130**

<b>Model</b>	<b>Z axis stroke</b> 130: 130mm	<b>Tool flange</b> No entry: None F: With tool flange	<b>Hollow shaft</b> No entry: None S: With hollow shaft	<b>Cable</b> 3L: 3.5m 5L: 5m 10L: 10m
--------------	------------------------------------	---	---	--

**RCX340-4**

<b>Controller / Number of controllable axes</b>	<b>Safety standard</b>	<b>Option A (OP.A)</b>	<b>Option B (OP.B)</b>	<b>Option C (OP.C)</b>	<b>Option D (OP.D)</b>	<b>Option E (OP.E)</b>	<b>Absolute battery</b>
---	------------------------	------------------------	------------------------	------------------------	------------------------	------------------------	-------------------------

Specify various controller setting items. RCX340 ▶ **P.508**

**RCX240**

<b>Controller</b>	<b>CE Marking</b>	<b>Regenerative unit</b>	<b>Expansion I/O</b>	<b>Network option</b>	<b>IVY System</b>	<b>Gripper</b>	<b>Battery</b>
-------------------	-------------------	--------------------------	----------------------	-----------------------	-------------------	----------------	----------------

Specify various controller setting items. RCX240/RCX240S ▶ **P.495**

## Specifications

		X-axis	Y-axis	Z-axis	R-axis
<b>Axis specifications</b>	<b>Arm length</b>	175 mm	175 mm	130 mm	-
	<b>Rotation angle</b>	+/-225 °	+/-225 °	-	+/-720 °
<b>AC servo motor output</b>		750 W	400 W	200 W	105 W
<b>Deceleration mechanism</b>	<b>Speed reducer</b>	Harmonic drive	Harmonic drive	Ball screw	Belt speed reduction
	<b>Transmission method</b>	Timing belt	Direct-coupled	Timing belt	Timing belt
	<b>Motor to speed reducer</b>				
	<b>Speed reducer to output</b>	Direct-coupled			
<b>Repeatability</b> <small>Note 1</small>		+/-0.01 mm		+/-0.01 mm	+/-0.01 °
<b>Maximum speed</b>		5.6 m/sec		1.5 m/sec	3000 °/sec
<b>Maximum payload</b> <small>Note 2</small>		5 kg			
<b>Standard cycle time: with 1kg payload</b> <small>Note 3</small>		0.32 sec (RCX340) / 0.38 sec (RCX240)			
<b>R-axis tolerable moment of inertia</b> <small>Note 4</small>	<b>Rated</b>	0.005 kgm <sup>2</sup>			
	<b>Maximum</b>	0.05 kgm <sup>2</sup>			
<b>User wiring</b>		0.15 sq × 8 wires			
<b>User tubing (Outer diameter)</b>		φ 6 × 2			
<b>Travel limit</b>		1.Soft limit 2.Mechanical stopper (X,Y,Z axis)			
<b>Robot cable length</b>		Standard: 3.5 m Option: 5 m, 10 m			
<b>Weight</b>		26 kg			

Note 1. This is the value at a constant ambient temperature.  
 Note 2. Tool flange specifications (option) are 4 kg.  
 Note 3. When moving a 1 kg load back and forth 300mm horizontally and 25mm vertically (rough positioning arch motion).  
 Note 4. Limits must be placed on parameters such as acceleration according to the moment of inertia being used.

## Controller

Controller	Power capacity (VA)	Operation method
RCX340 RCX240-R3	2500	Programming / I/O point trace / Remote command / Operation using RS-232C communication

**R-axis moment of inertia (load inertia)**  
 Recommended positional relationship between the load weight and the offset amount from the center of the R-axis (center of gravity position)

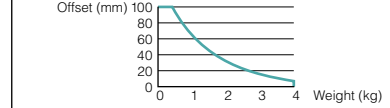

Note. When the payload exceeds 4kg, it is predicted that the R-axis moment of inertia may exceed the rated value. So, make proper parameter setting.

Note. "Harmonic" and "Harmonic drive" are the registered trademarks of Harmonic Drive Systems Inc.  
 Note. To set the standard coordinates with high accuracy, use a standard coordinate setting jig (option). Refer to the user's manual (installation manual) for more details.

Our robot manuals (installation manuals) can be downloaded from our website at the address below:  
<http://global.yamaha-motor.com/business/robot/>

## YK350TW

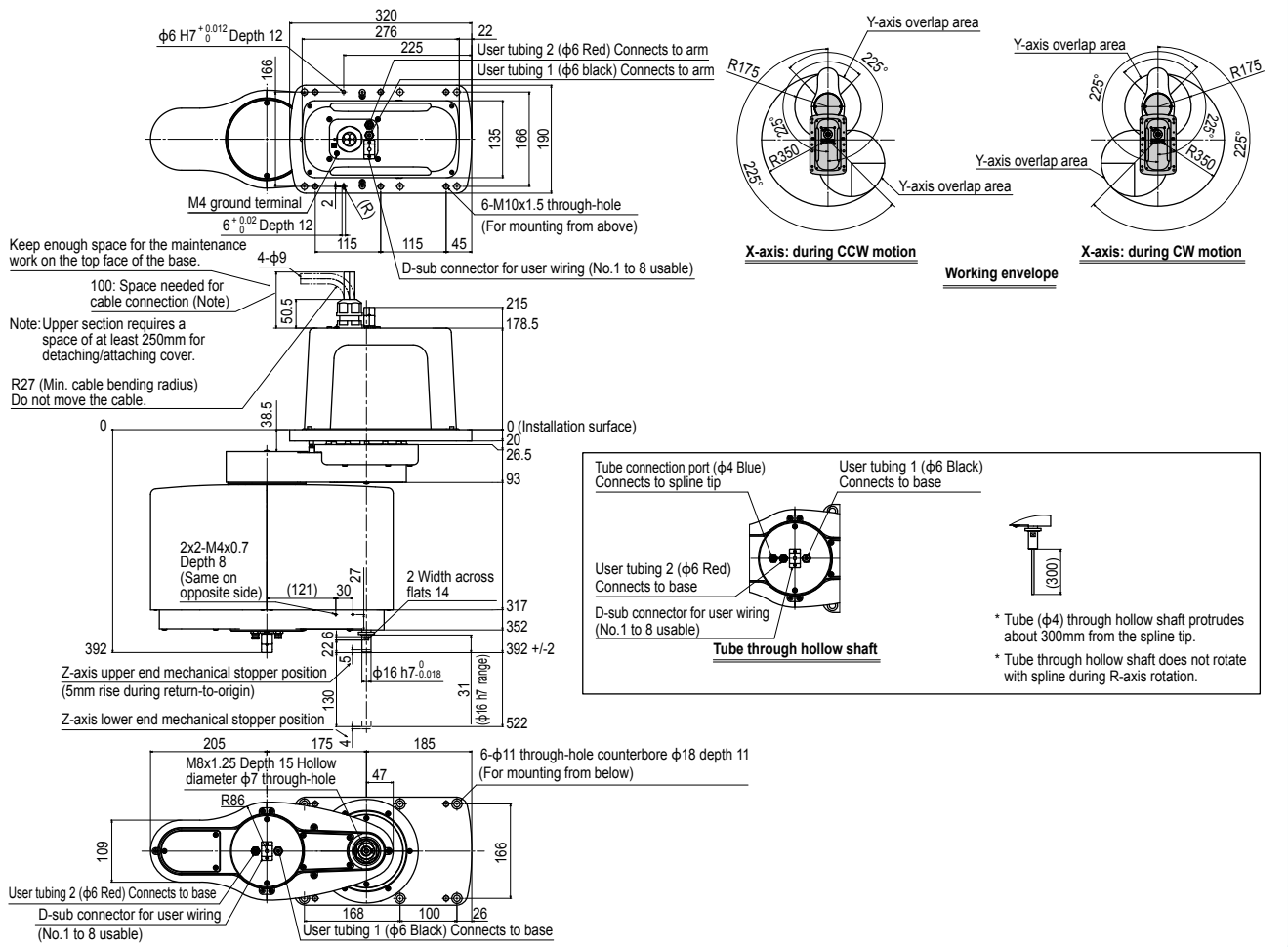

YK350TW Tool flange mount type

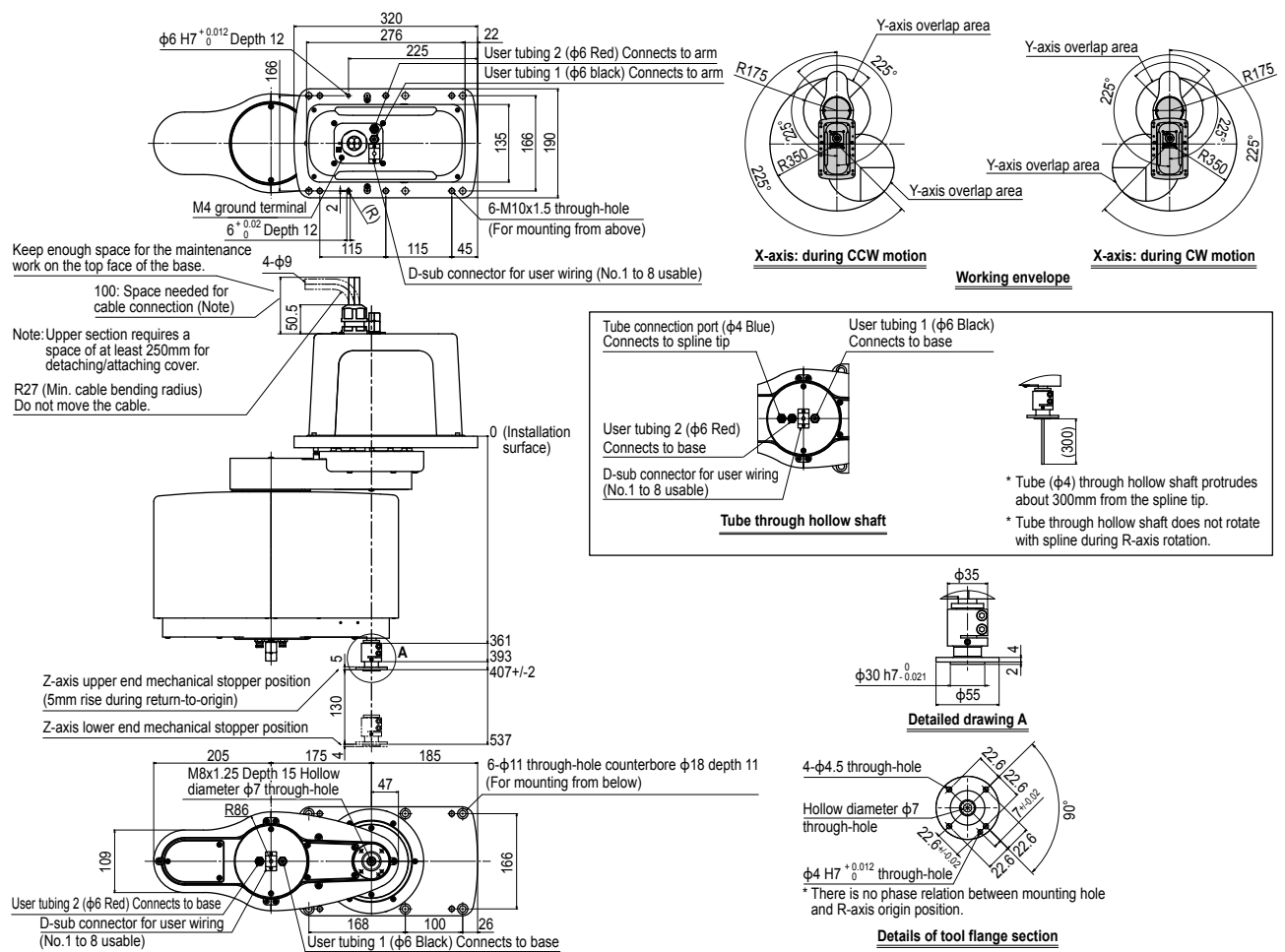

# YK500TW

Orbit type



- Arm length 500mm
- Maximum payload 5kg

## Ordering method

**YK500TW-130**

<b>Model</b>	<b>Z axis stroke</b> 130: 130mm	<b>Tool flange</b> No entry: None F: With tool flange	<b>Hollow shaft</b> No entry: None S: With hollow shaft	<b>Cable</b> 3L: 3.5m 5L: 5m 10L: 10m
--------------	------------------------------------	---	---	--

**RCX340-4**

<b>Controller / Number of controllable axes</b>	<b>Safety standard</b>	<b>Option A (OP.A)</b>	<b>Option B (OP.B)</b>	<b>Option C (OP.C)</b>	<b>Option D (OP.D)</b>	<b>Option E (OP.E)</b>	<b>Absolute battery</b>
---	------------------------	------------------------	------------------------	------------------------	------------------------	------------------------	-------------------------

Specify various controller setting items. RCX340 ▶ **P.508**

**RCX240**

<b>Controller</b>	<b>CE Marking</b>	<b>Regenerative unit</b>	<b>Expansion I/O</b>	<b>Network option</b>	<b>IVY System</b>	<b>Gripper</b>	<b>Battery</b>
-------------------	-------------------	--------------------------	----------------------	-----------------------	-------------------	----------------	----------------

Specify various controller setting items. RCX240/RCX240S ▶ **P.495**

## Specifications

		X-axis	Y-axis	Z-axis	R-axis
<b>Axis specifications</b>	<b>Arm length</b>	250 mm	250 mm	130 mm	-
	<b>Rotation angle</b>	+/-225 °	+/-225 °	-	+/-720 °
<b>AC servo motor output</b>		750 W	400 W	200 W	105 W
<b>Deceleration mechanism</b>	<b>Speed reducer</b>	Harmonic drive	Harmonic drive	Ball screw	Belt speed reduction
	<b>Transmission method</b>	Timing belt	Direct-coupled	Timing belt	Timing belt
	<b>Motor to speed reducer</b>	Timing belt	Direct-coupled	Timing belt	
<b>Speed reducer to output</b>	Direct-coupled				
<b>Repeatability</b> <small>Note 1</small>		+/-0.015 mm		+/-0.01 mm	+/-0.01 °
<b>Maximum speed</b>		6.8 m/sec		1.5 m/sec	3000 °/sec
<b>Maximum payload</b> <small>Note 2</small>		5 kg (RCX340), 4 kg (RCX240)			
<b>Standard cycle time: with 1kg payload</b> <small>Note 3</small>		0.29 sec			
<b>R-axis tolerable moment of inertia</b> <small>Note 4</small>	<b>Rated</b>	0.005 kgm <sup>2</sup>			
	<b>Maximum</b>	0.05 kgm <sup>2</sup>			
<b>User wiring</b>		0.15 sq × 8 wires			
<b>User tubing (Outer diameter)</b>		φ 6 × 2			
<b>Travel limit</b>		1.Soft limit 2.Mechanical stopper (X,Y,Z axis)			
<b>Robot cable length</b>		Standard: 3.5 m Option: 5 m, 10 m			
<b>Weight</b>		27 kg			

Note 1. This is the value at a constant ambient temperature.  
 Note 2. For the option specifications (tool flange mount type), the maximum payload becomes 4 kg (RCX340) or 3 kg (RCX240).  
 Note 3. When moving a 1 kg load back and forth 300 mm horizontally and 25 mm vertically (rough positioning arch motion).  
 Note 4. Limits must be placed on parameters such as acceleration according to the moment of inertia being used. See P.536.

## Controller

Controller	Power capacity (VA)	Operation method
RCX340 RCX240-R3	2500	Programming / I/O point trace / Remote command / Operation using RS-232C communication

**R-axis moment of inertia (load inertia)**  
 Recommended positional relationship between the load weight and the offset amount from the center of the R-axis (center of gravity position)

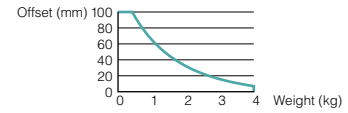

Note. "Harmonic" and "Harmonic drive" are the registered trademarks of Harmonic Drive Systems Inc.  
 Note. To set the standard coordinates with high accuracy, use a standard coordinate setting jig (option). Refer to the user's manual (installation manual) for more details.

Our robot manuals (installation manuals) can be downloaded from our website at the address below:  
<http://global.yamaha-motor.com/business/robot/>

## YK500TW

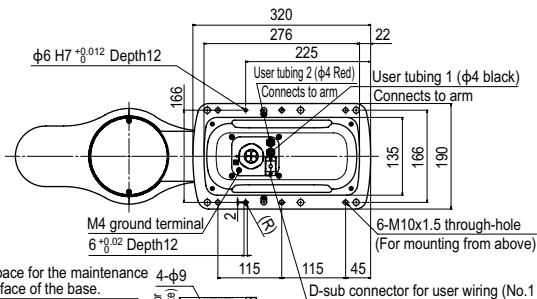

Keep enough space for the maintenance 4-φ9 work on the top face of the base.

Note: Upper section requires a space of at least 250mm for detaching/attaching cover.

R27 (Min. cable bending radius) Do not move the cable.

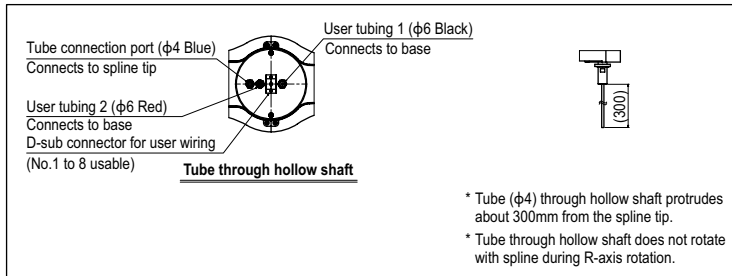
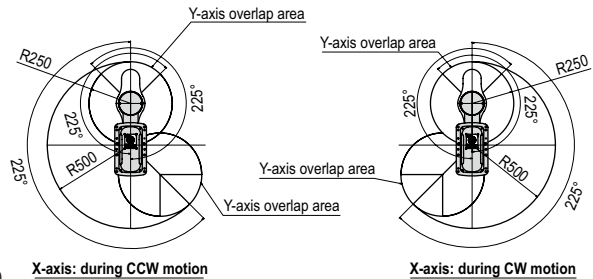
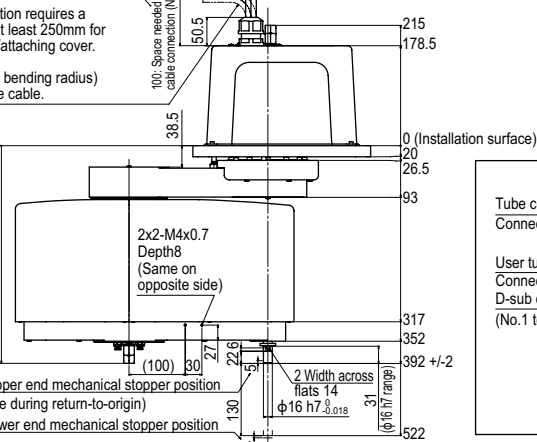

\* Tube (φ4) through hollow shaft protrudes about 300mm from the spline tip.  
 \* Tube through hollow shaft does not rotate with spline during R-axis rotation.

YK500TW Tool flange mount type

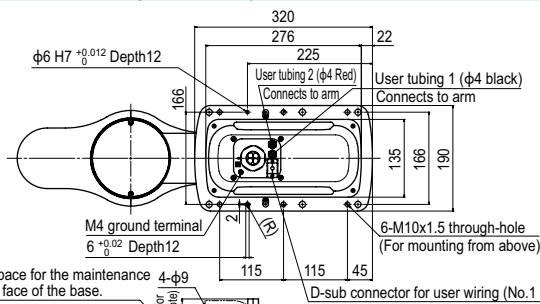

Keep enough space for the maintenance work on the top face of the base.

Note: Upper section requires a space of at least 250mm for detaching/attaching cover.

R27 (Min. cable bending radius) Do not move the cable.

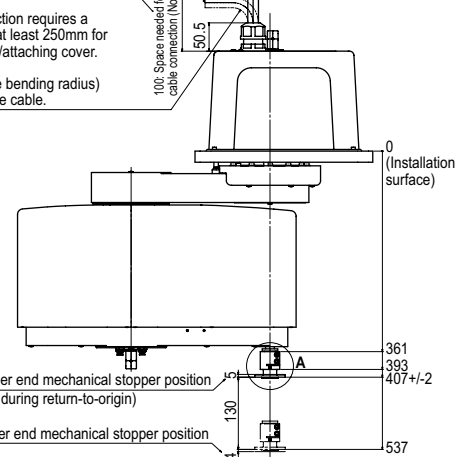

Z-axis upper end mechanical stopper position (5mm rise during return-to-origin)

Z-axis lower end mechanical stopper position

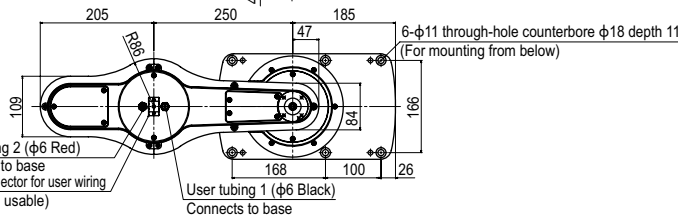

User tubing 2 (φ6 Red) Connects to base D-sub connector for user wiring (No.1 to 8 usable)

User tubing 1 (φ6 Black) Connects to base

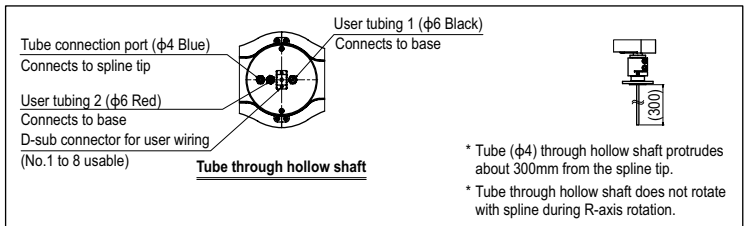
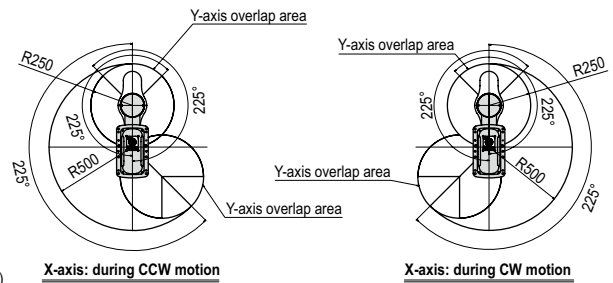

\* Tube (φ4) through hollow shaft protrudes about 300mm from the spline tip.  
\* Tube through hollow shaft does not rotate with spline during R-axis rotation.

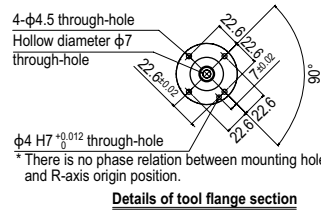
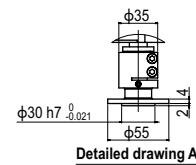

\* There is no phase relation between mounting hole and R-axis origin position.



# YK120XG

Standard type: Tiny type

- Arm length 120mm
- Maximum payload 1kg

## Ordering method

**YK120XG - 50**

<b>Model</b>	<b>Z axis stroke</b>	<b>Cable</b>
	50: 50mm	2L: 2m
		3L: 3.5m
		5L: 5m
		10L: 10m

**RCX340-4**

<b>Controller / Number of controllable axes</b>	<b>Safety standard</b>	<b>Option A (OP.A)</b>	<b>Option B (OP.B)</b>	<b>Option C (OP.C)</b>	<b>Option D (OP.D)</b>	<b>Option E (OP.E)</b>	<b>Absolute battery</b>
---	------------------------	------------------------	------------------------	------------------------	------------------------	------------------------	-------------------------

Specify various controller setting items. RCX340 ▶ **P.508**

**RCX240S**

<b>Controller</b>	<b>CE Marking</b>	<b>Expansion I/O</b>	<b>Network option</b>	<b>iVY System</b>	<b>Gripper</b>	<b>Battery</b>
-------------------	-------------------	----------------------	-----------------------	-------------------	----------------	----------------

Specify various controller setting items. RCX240/RCX240S ▶ **P.495**

## Specifications

		X-axis	Y-axis	Z-axis	R-axis
<b>Axis specifications</b>	<b>Arm length</b>	45 mm	75 mm	50 mm	-
	<b>Rotation angle</b>	+/-125 °	+/-145 °	-	+/-360 °
<b>AC servo motor output</b>		30 W	30 W	30 W	30 W
<b>Deceleration mechanism</b>	<b>Speed reducer</b>	Harmonic drive	Harmonic drive	Ball screw	Harmonic drive
	<b>Transmission method</b>	Direct-coupled			
	<b>Motor to speed reducer</b>	Direct-coupled			
	<b>Speed reducer to output</b>	Direct-coupled			
<b>Repeatability</b> <small>Note 1</small>		+/-0.01 mm		+/-0.01 mm	+/-0.004 °
<b>Maximum speed</b>		3.3 m/sec		0.9 m/sec	1700 °/sec
<b>Maximum payload</b>		1.0 kg			
<b>Standard cycle time: with 0.1kg payload</b> <small>Note 2</small>		0.33 sec			
<b>R-axis tolerable moment of inertia</b> <small>Note 3</small>		0.01 kgm <sup>2</sup>			
<b>User wiring</b>		0.1 sq × 8 wires			
<b>User tubing (Outer diameter)</b>		φ 4 × 2			
<b>Travel limit</b>		1.Soft limit 2.Mechanical stopper (X,Y,Z axis)			
<b>Robot cable length</b>		Standard: 2 m Option: 3.5 m, 5 m, 10 m			
<b>Weight (Excluding robot cable)</b> <small>Note 4</small>		3.9 kg			
<b>Robot cable weight</b>		0.9 kg (2 m)	1.5 kg (3.5 m)	2.1 kg (5 m)	4.2 kg (10 m)

Note 1. This is the value at a constant ambient temperature. (X,Y axes)  
 Note 2. When moving 25mm in vertical direction and 100mm in horizontal direction reciprocally.  
 Note 3. There are limits to acceleration coefficient settings. See P.536.  
 Note 4. The total robot weight is the sum of the robot body weight and the cable weight.

## Controller

Controller	Power capacity (VA)	Operation method
RCX340 RCX240S	300	Programming / I/O point trace / Remote command / Operation using RS-232C communication

Note. "Harmonic" and "Harmonic drive" are the registered trademarks of Harmonic Drive Systems Inc.  
 Note. The movement range can be limited by changing the positions of X and Y axis mechanical stoppers. (The movement range is set to the maximum at the time of shipment.)  
 See our robot manuals (installation manuals) for detailed information.

Our robot manuals (installation manuals) can be downloaded from our website at the address below:  
<http://global.yamaha-motor.com/business/robot/>

## YK120XG

Connector for user wiring (No. 1 to 8 usable, socket contact)  
 J.S.T. Mfg Co., Ltd. SM connector SMR-8V-B, pin SYM-001T-P0.6 (supplied)  
 Use the YC12 crimping tool.

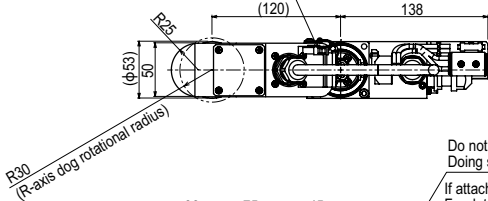

If the robot enters the inside of R12, the Z-axis upper end stopper may be in contact with the base. So, do not perform such motion.

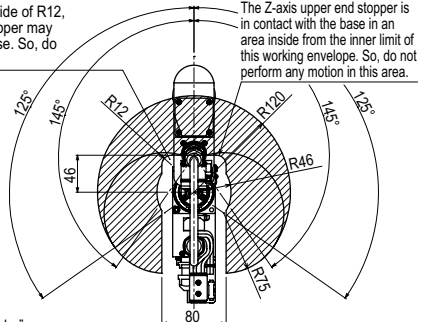

### Working envelope

X, Y-axis origin is at ±5° with respect to front of robot base  
 When performing return-to-origin, move the axes counterclockwise in advance from the position shown above.

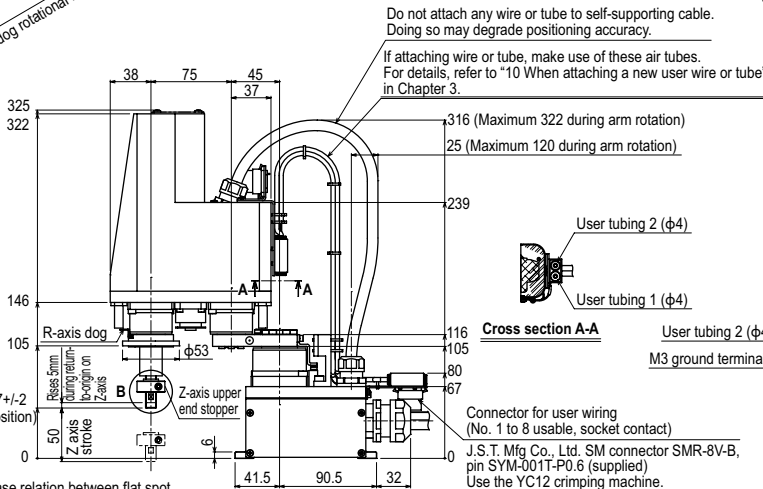

No phase relation between flat spot and R-axis origin  
 User tool installation range

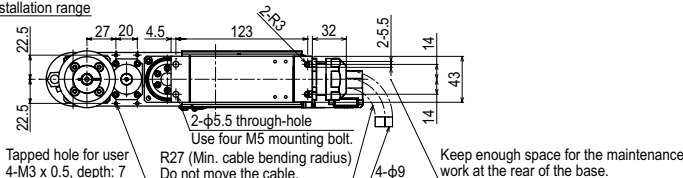
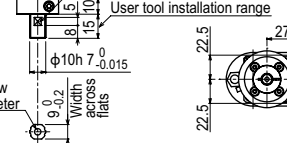

# YK150XG

Standard type: Tiny type

- Arm length 150mm
- Maximum payload 1kg

## Ordering method

**YK150XG - 50**

<b>Model</b>	<b>Z axis stroke</b>	<b>Cable</b>
	50: 50mm	2L: 2m
		3L: 3.5m
		5L: 5m
		10L: 10m

**RCX340-4**

<b>Controller / Number of controllable axes</b>	<b>Safety standard</b>	<b>Option A (OP.A)</b>	<b>Option B (OP.B)</b>	<b>Option C (OP.C)</b>	<b>Option D (OP.D)</b>	<b>Option E (OP.E)</b>	<b>Absolute battery</b>
---	------------------------	------------------------	------------------------	------------------------	------------------------	------------------------	-------------------------

Specify various controller setting items. RCX340 ▶ **P.508**

**RCX240S**

<b>Controller</b>	<b>CE Marking</b>	<b>Expansion I/O</b>	<b>Network option</b>	<b>iVY System</b>	<b>Gripper</b>	<b>Battery</b>
-------------------	-------------------	----------------------	-----------------------	-------------------	----------------	----------------

Specify various controller setting items. RCX240/RCX240S ▶ **P.495**

## Specifications

		X-axis	Y-axis	Z-axis	R-axis
<b>Axis specifications</b>	<b>Arm length</b>	75 mm	75 mm	50 mm	–
	<b>Rotation angle</b>	+/-125 °	+/-145 °	–	+/-360 °
<b>AC servo motor output</b>		30 W	30 W	30 W	30 W
<b>Deceleration mechanism</b>	<b>Speed reducer</b>	Harmonic drive	Harmonic drive	Ball screw	Harmonic drive
	<b>Transmission method</b>	Direct-coupled			
	<b>Motor to speed reducer</b> <b>Speed reducer to output</b>	Direct-coupled			
<b>Repeatability</b> <sup>Note 1</sup>	+/-0.01 mm		+/-0.01 mm	+/-0.004 °	
<b>Maximum speed</b>		3.4 m/sec	0.9 m/sec	1700 °/sec	
<b>Maximum payload</b>		1.0 kg			
<b>Standard cycle time: with 0.1kg payload</b> <sup>Note 2</sup>		0.33 sec			
<b>R-axis tolerable moment of inertia</b> <sup>Note 3</sup>		0.01 kgm <sup>2</sup>			
<b>User wiring</b>		0.1 sq × 8 wires			
<b>User tubing (Outer diameter)</b>		φ 4 × 2			
<b>Travel limit</b>		1.Soft limit 2.Mechanical stopper (X,Y,Z axis)			
<b>Robot cable length</b>		Standard: 2 m Option: 3.5 m, 5 m, 10 m			
<b>Weight (Excluding robot cable)</b> <sup>Note 4</sup>		4.0 kg			
<b>Robot cable weight</b>		0.9 kg (2 m)	1.5 kg (3.5 m)	2.1 kg (5 m)	4.2 kg (10 m)

Note 1. This is the value at a constant ambient temperature. (X,Y axes)  
 Note 2. When moving 25mm in vertical direction and 100mm in horizontal direction reciprocally.  
 Note 3. There are limits to acceleration coefficient settings. See P.536.  
 Note 4. The total robot weight is the sum of the robot body weight and the cable weight.

## Controller

Controller	Power capacity (VA)	Operation method
RCX340 RCX240S	300	Programming / I/O point trace / Remote command / Operation using RS-232C communication

Note. "Harmonic" and "Harmonic drive" are the registered trademarks of Harmonic Drive Systems Inc.

Note. The movement range can be limited by changing the positions of X and Y axis mechanical stoppers. (The movement range is set to the maximum at the time of shipment.) See our robot manuals (installation manuals) for detailed information.

Our robot manuals (installation manuals) can be downloaded from our website at the address below:  
<http://global.yamaha-motor.com/business/robot/>

## YK150XG

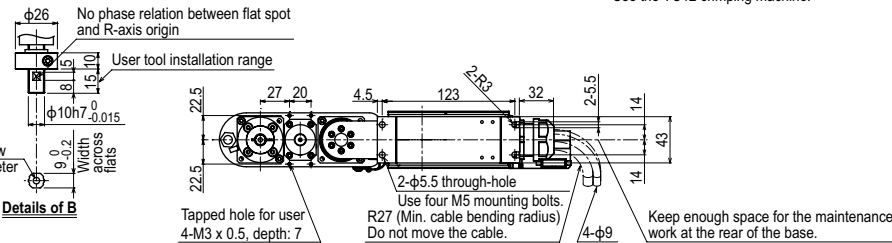
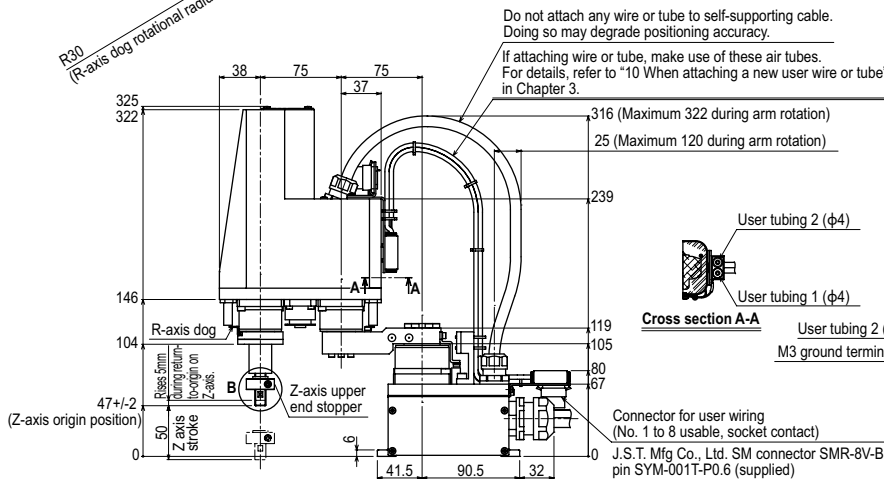
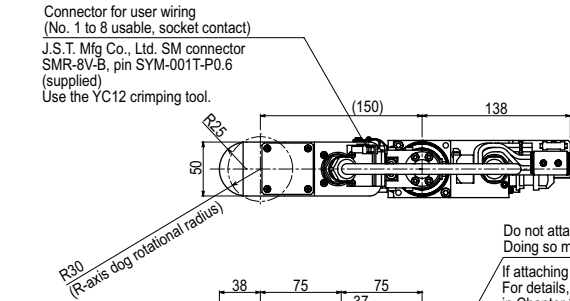

If the robot enters the inside of R12, the Z-axis upper end stopper may be in contact with the base. So, do not perform such motion.

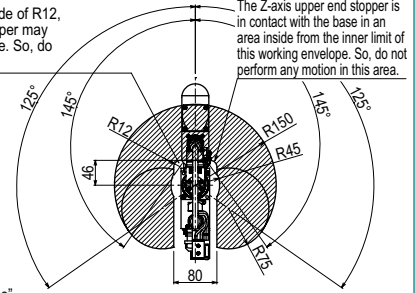

X, Y-axis origin is at ±5° with respect to front of robot base  
 When performing return-to-origin, move the axes counterclockwise in advance from the position shown above.

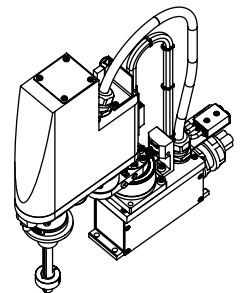
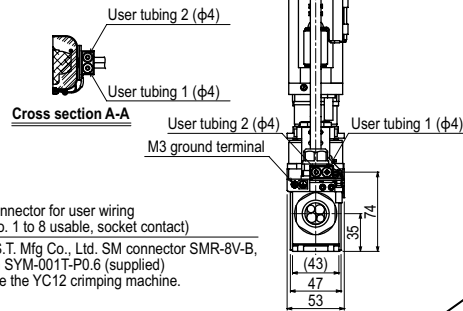

Controller

**RCX340 ▶ 508 RCX240S ▶ 495**

APPLICATION  
 Linear conveyor modules  
 LCM100  
 Compact single-axis robots  
 TRANSERVO  
 Single-axis robots  
 FLIP-X  
 Linear motor single-axis robots  
 PHASER  
 Cartesian robots  
 XX-X  
 SCARA robots  
 YK-X  
 Pick & place robots  
 YP-X  
 CLEAN  
 CONTROLLER  
 INFORMATION  
 Tiny type  
 Small / Medium type  
 Large type  
 Walk-mount / Inverse type  
 Dust-proof & drip-proof type

# YK180XG

Standard type: Tiny type

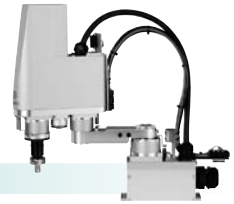

- Arm length 180mm
- Maximum payload 1kg

## Ordering method

**YK180XG - 50**

<b>Model</b>	<b>Z axis stroke</b>	<b>Cable</b>
	50: 50mm	2L: 2m
		3L: 3.5m
		5L: 5m
		10L: 10m

**RCX340-4**

<b>Controller / Number of controllable axes</b>	<b>Safety standard</b>	<b>Option A (OP.A)</b>	<b>Option B (OP.B)</b>	<b>Option C (OP.C)</b>	<b>Option D (OP.D)</b>	<b>Option E (OP.E)</b>	<b>Absolute battery</b>
---	------------------------	------------------------	------------------------	------------------------	------------------------	------------------------	-------------------------

Specify various controller setting items. RCX340 ▶ **P.508**

**RCX240S**

<b>Controller</b>	<b>CE Marking</b>	<b>Expansion I/O</b>	<b>Network option</b>	<b>iVY System</b>	<b>Gripper</b>	<b>Battery</b>
-------------------	-------------------	----------------------	-----------------------	-------------------	----------------	----------------

Specify various controller setting items. RCX240/RCX240S ▶ **P.495**

## Specifications

		X-axis	Y-axis	Z-axis	R-axis
<b>Axis specifications</b>	<b>Arm length</b>	105 mm	75 mm	50 mm	—
	<b>Rotation angle</b>	+/-125 °	+/-145 °	—	+/-360 °
<b>AC servo motor output</b>		30 W	30 W	30 W	30 W
<b>Deceleration mechanism</b>	<b>Speed reducer</b>	Harmonic drive	Harmonic drive	Ball screw	Harmonic drive
	<b>Transmission method</b>	Direct-coupled			
	<b>Motor to speed reducer</b> <b>Speed reducer to output</b>	Direct-coupled			
<b>Repeatability</b> <sup>Note 1</sup>	+/-0.01 mm		+/-0.01 mm		+/-0.004 °
<b>Maximum speed</b>	3.3 m/sec		0.9 m/sec		1700 °/sec
<b>Maximum payload</b>		1.0 kg			
<b>Standard cycle time: with 0.1kg payload</b> <sup>Note 2</sup>		0.33 sec			
<b>R-axis tolerable moment of inertia</b> <sup>Note 3</sup>		0.01 kgm <sup>2</sup>			
<b>User wiring</b>		0.1 sq × 8 wires			
<b>User tubing (Outer diameter)</b>		φ 4 × 2			
<b>Travel limit</b>		1.Soft limit 2.Mechanical stopper (X,Y,Z axis)			
<b>Robot cable length</b>		Standard: 2 m Option: 3.5 m, 5 m, 10 m			
<b>Weight (Excluding robot cable)</b> <sup>Note 4</sup>		4.1 kg			
<b>Robot cable weight</b>		0.9 kg (2 m)	1.5 kg (3.5 m)	2.1 kg (5 m)	4.2 kg (10 m)

Note 1. This is the value at a constant ambient temperature. (X,Y axes)  
 Note 2. When moving 25mm in vertical direction and 100mm in horizontal direction reciprocally.  
 Note 3. There are limits to acceleration coefficient settings. See P.536.  
 Note 4. The total robot weight is the sum of the robot body weight and the cable weight.

## Controller

Controller	Power capacity (VA)	Operation method
RCX340 RCX240S	500	Programming / I/O point trace / Remote command / Operation using RS-232C communication

Note. "Harmonic" and "Harmonic drive" are the registered trademarks of Harmonic Drive Systems Inc.  
 Note. The movement range can be limited by changing the positions of X and Y axis mechanical stoppers. (The movement range is set to the maximum at the time of shipment.)  
 See our robot manuals (installation manuals) for detailed information.

Our robot manuals (installation manuals) can be downloaded from our website at the address below:  
<http://global.yamaha-motor.com/business/robot/>

## YK180XG

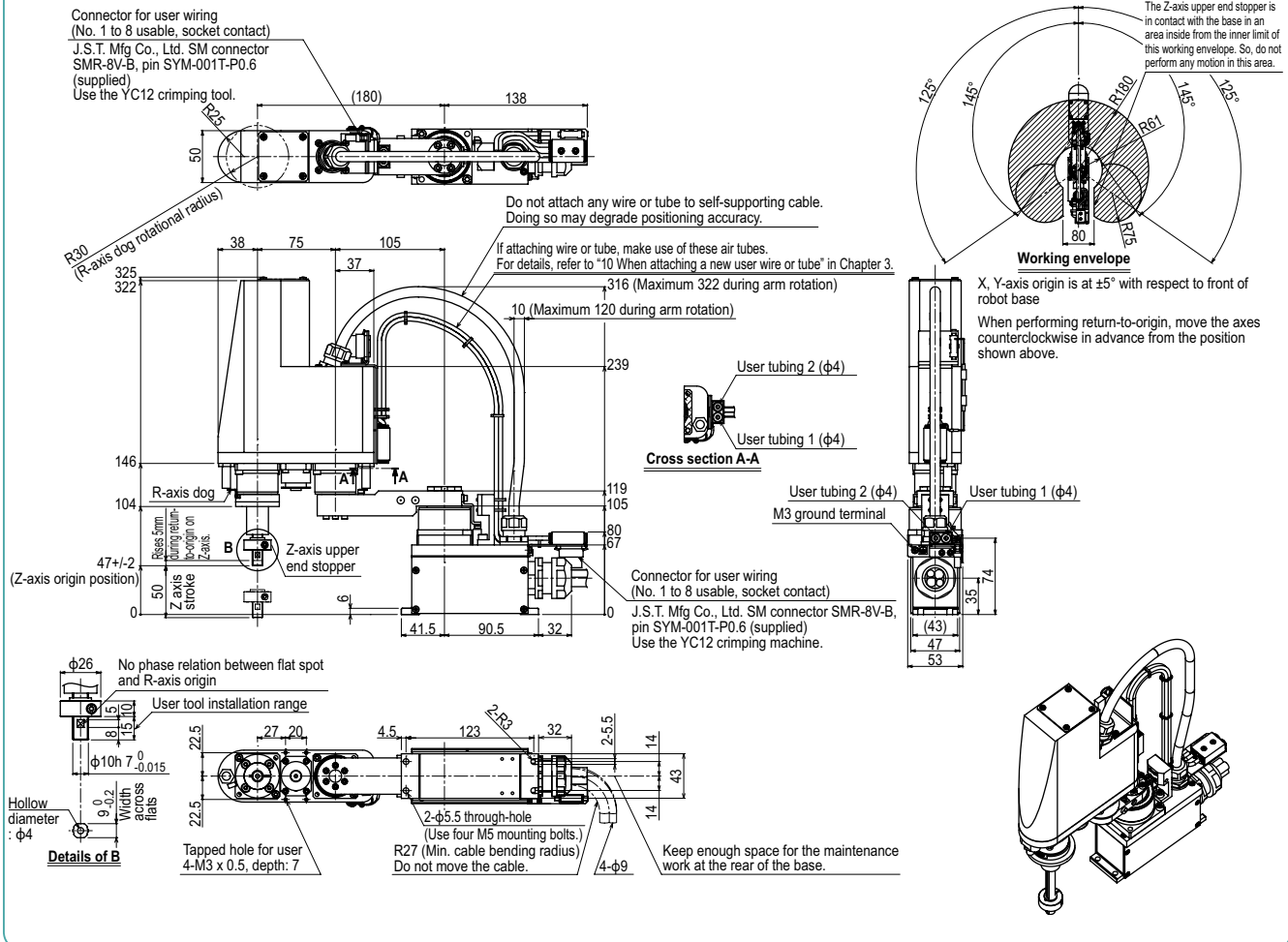

# YK180X

Standard type: Tiny type

- Arm length 180mm
- Maximum payload 1kg



## Ordering method

**YK180X - 100**

<b>Model</b>	<b>Z axis stroke</b>	<b>Cable</b>
	100: 100mm	3L: 3.5m 5L: 5m 10L: 10m

**RCX340-4**

<b>Controller / Number of controllable axes</b>	<b>Safety standard</b>	<b>Option A (OP.A)</b>	<b>Option B (OP.B)</b>	<b>Option C (OP.C)</b>	<b>Option D (OP.D)</b>	<b>Option E (OP.E)</b>	<b>Absolute battery</b>
---	------------------------	------------------------	------------------------	------------------------	------------------------	------------------------	-------------------------

Specify various controller setting items. RCX340 ▶ **P.508**

**RCX240S**

<b>Controller</b>	<b>CE Marking</b>	<b>Expansion I/O</b>	<b>Network option</b>	<b>iVY System</b>	<b>Gripper</b>	<b>Battery</b>
-------------------	-------------------	----------------------	-----------------------	-------------------	----------------	----------------

Specify various controller setting items. RCX240/RCX240S ▶ **P.495**

## Specifications

		X-axis	Y-axis	Z-axis	R-axis
<b>Axis specifications</b>	<b>Arm length</b>	71 mm	109 mm	100 mm	—
	<b>Rotation angle</b>	+/-120 °	+/-140 °	—	+/-360 °
<b>AC servo motor output</b>		50 W	30 W	30 W	30 W
<b>Deceleration mechanism</b>	<b>Speed reducer</b>	Harmonic drive	Harmonic drive	Ball screw	Harmonic drive
	<b>Transmission method</b>	Direct-coupled			
	<b>Motor to speed reducer / Speed reducer to output</b>	Direct-coupled			
<b>Repeatability</b> <small>Note 1</small>	+/-0.01 mm		+/-0.01 mm	+/-0.004 °	
<b>Maximum speed</b>		3.3 m/sec		0.7 m/sec	1700 °/sec
<b>Maximum payload</b>		1.0 kg			
<b>Standard cycle time: with 0.1kg payload</b> <small>Note 2</small>		0.39 sec			
<b>R-axis tolerable moment of inertia</b> <small>Note 3</small>		0.01 kgm <sup>2</sup>			
<b>User wiring</b>		0.1 sq × 6 wires			
<b>User tubing (Outer diameter)</b>		φ 3 × 2			
<b>Travel limit</b>		1.Soft limit 2.Mechanical stopper (X,Y,Z axis)			
<b>Robot cable length</b>		Standard: 3.5 m Option: 5 m, 10 m			
<b>Weight (Excluding robot cable)</b> <small>Note 4</small>		5.5 kg			
<b>Robot cable weight</b>		1.5 kg (3.5 m)	2.1 kg (5 m)	4.2 kg (10 m)	

Note 1. This is the value at a constant ambient temperature.  
 Note 2. When reciprocating 100mm in horizontal and 25mm in vertical directions.  
 Note 3. There are limits to acceleration coefficient settings. See P.536.  
 Note 4. The total robot weight is the sum of the robot body weight and the cable weight.

## Controller

Controller	Power capacity (VA)	Operation method
RCX340 RCX240S	500	Programming / I/O point trace / Remote command / Operation using RS-232C communication

Note. "Harmonic" and "Harmonic drive" are the registered trademarks of Harmonic Drive Systems Inc.  
 Note. The movement range can be limited by changing the positions of X and Y axis mechanical stoppers. (The movement range is set to the maximum at the time of shipment.)  
 See our robot manuals (installation manuals) for detailed information.

Our robot manuals (installation manuals) can be downloaded from our website at the address below:  
<http://global.yamaha-motor.com/business/robot/>

## YK180X

Connector for user wiring  
 (No. 1 to 6 usable, socket contact)  
 J.S.T. Mfg Co., Ltd. SM connector  
 SMR-6VB, pin SYM-001T-P0.6 (supplied)  
 Use the YC12 crimping tool.

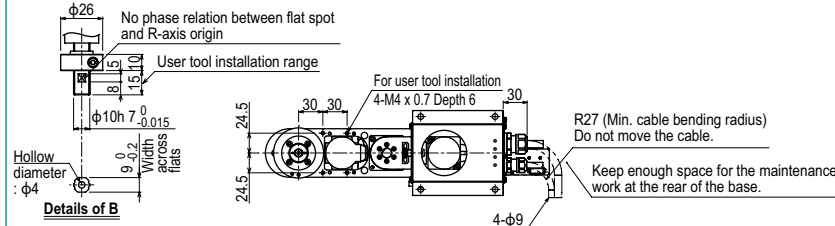
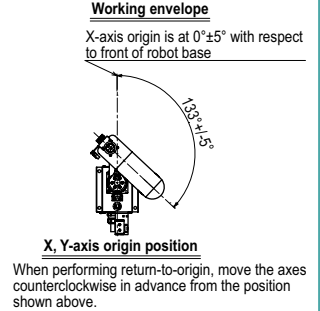
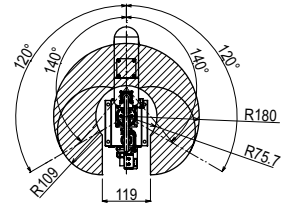
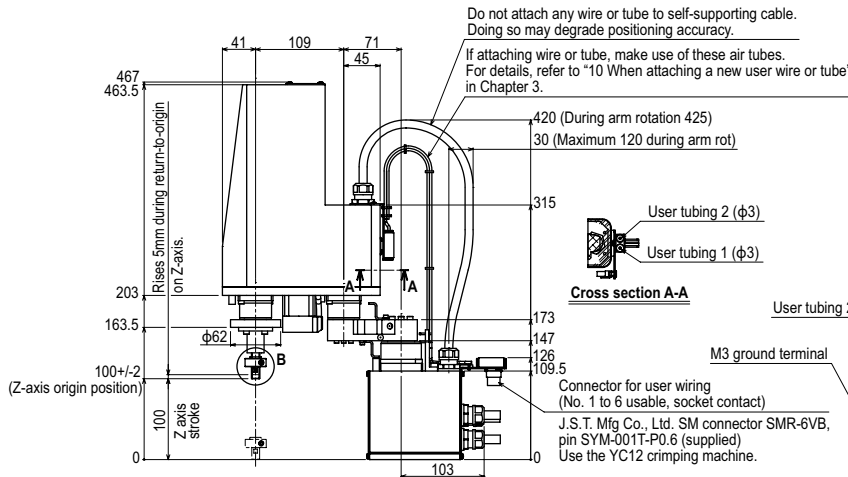
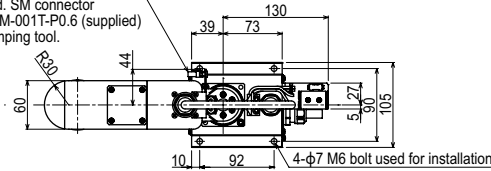

APPLICATION  
 Linear conveyor modules  
 LCM100  
 TRANSEURO  
 Compact single-axis robots  
 FLIP-X  
 Single-axis robots  
 PHASER  
 Linear motor single-axis robots  
 XX-X  
 Cartesian robots  
 YK-X  
 SCA RA robots  
 YK-X  
 Pick & place robots  
 YP-X  
 CLEAN  
 CONTROLLER INFORMATION  
 Tiny type  
 Small / Medium type  
 Large type  
 Walk-mount / Inverse type  
 Dust-proof & drip-proof type

# YK220X

Standard type: Tiny type



- Arm length 220mm
- Maximum payload 1kg

## Ordering method

**YK220X - 100**

Model	Z axis stroke	Cable	Controller / Number of controllable axes	Safety standard	Option A (OP.A)	Option B (OP.B)	Option C (OP.C)	Option D (OP.D)	Option E (OP.E)	Absolute battery
	100: 100mm	3L: 3.5m 5L: 5m 10L: 10m	<b>RCX340-4</b>							
			Specify various controller setting items. RCX340 ▶ <b>P.508</b>							
			<b>RCX240S</b>							<b>BB</b>
			Specify various controller setting items. RCX240/RCX240S ▶ <b>P.495</b>							

## Specifications

		X-axis	Y-axis	Z-axis	R-axis
Axis specifications	Arm length	111 mm	109 mm	100 mm	-
	Rotation angle	+/-120 °	+/-140 °	-	+/-360 °
AC servo motor output		50 W	30 W	30 W	30 W
Deceleration mechanism	Speed reducer	Harmonic drive	Harmonic drive	Ball screw	Harmonic drive
	Transmission method	Direct-coupled			
	Motor to speed reducer Speed reducer to output	Direct-coupled			
Repeatability <sup>Note 1</sup>		+/-0.01 mm	+/-0.01 mm	+/-0.01 mm	+/-0.004 °
Maximum speed		3.4 m/sec	0.7 m/sec		1700 °/sec
Maximum payload		1.0 kg			
Standard cycle time: with 0.1kg payload <sup>Note 2</sup>		0.42 sec			
R-axis tolerable moment of inertia <sup>Note 3</sup>		0.01 kgm <sup>2</sup>			
User wiring		0.1 sq × 6 wires			
User tubing (Outer diameter)		φ 3 × 2			
Travel limit		1.Soft limit 2.Mechanical stopper (X,Y,Z axis)			
Robot cable length		Standard: 3.5 m Option: 5 m, 10 m			
Weight (Excluding robot cable) <sup>Note 4</sup>		5.5 kg			
Robot cable weight		1.5 kg (3.5 m)	2.1 kg (5 m)	4.2 kg (10 m)	

Note 1. This is the value at a constant ambient temperature.  
 Note 2. When reciprocating 100mm in horizontal and 25mm in vertical directions.  
 Note 3. There are limits to acceleration coefficient settings. See P.536.  
 Note 4. The total robot weight is the sum of the robot body weight and the cable weight.

## Controller

Controller	Power capacity (VA)	Operation method
RCX340 RCX240S	500	Programming / I/O point trace / Remote command / Operation using RS-232C communication

Note. "Harmonic" and "Harmonic drive" are the registered trademarks of Harmonic Drive Systems Inc.

Note. The movement range can be limited by changing the positions of X and Y axis mechanical stoppers. (The movement range is set to the maximum at the time of shipment.) See our robot manuals (installation manuals) for detailed information.

Our robot manuals (installation manuals) can be downloaded from our website at the address below:  
<http://global.yamaha-motor.com/business/robot/>

## YK220X

Connector for user wiring  
 (No. 1 to 6 usable, socket contact)  
 J.S.T. Mfg Co., Ltd. SM connector  
 SMR-6VB, pin SYM-001T-P0.6 (supplied)  
 Use the YC12 crimping tool.

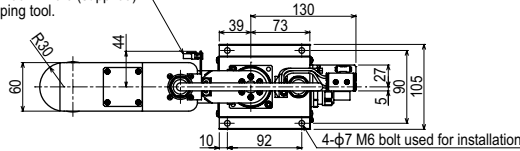

Do not attach any wire or tube to self-supporting cable. Doing so may degrade positioning accuracy.

If attaching wire or tube, make use of these air tubes. For details, refer to "10 When attaching a new user wire or tube" in Chapter 3.

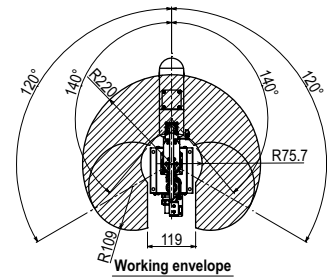
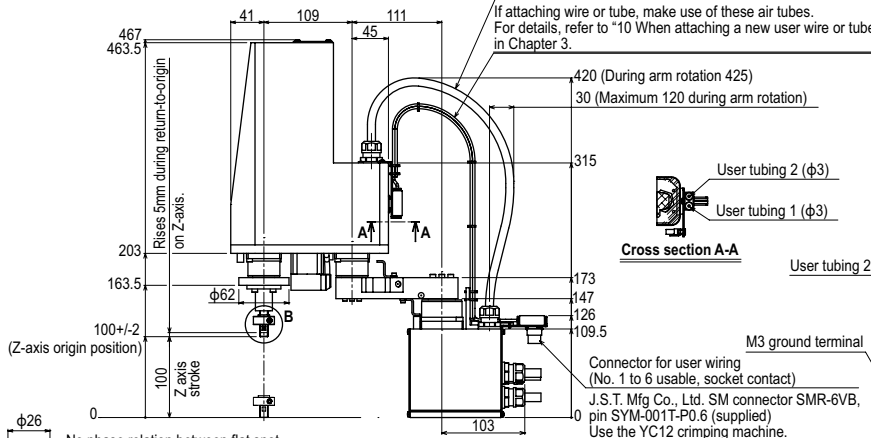

X-axis origin is at 0°±5° with respect to front of robot base

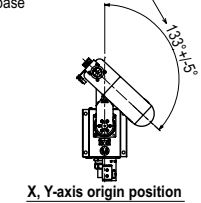

No phase relation between flat spot and R-axis origin

User tool installation range

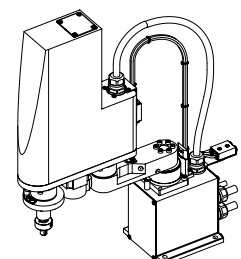
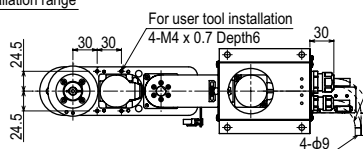
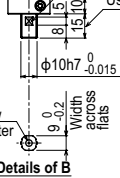

# YK250XG

Standard type: Small type

- Arm length 250mm
- Maximum payload 5kg

## Ordering method

### YK250XG - 150

Model	Z axis stroke	Tool flange	Hollow shaft	Cable
	150: 150mm	No entry: None F: With tool flange	No entry: None S: With hollow shaft	3L: 3.5m 5L: 5m 10L: 10m

### RCX340-4

Controller / Number of controllable axes	Safety standard	Option A (OP.A)	Option B (OP.B)	Option C (OP.C)	Option D (OP.D)	Option E (OP.E)	Absolute battery

Specify various controller setting items. RCX340 ▶ P.508

### RCX240S

Controller	CE Marking	Expansion I/O	Network option	IVY System	Gripper	Battery
						BB

Specify various controller setting items. RCX240/RCX240S ▶ P.495

## Specifications

		X-axis	Y-axis	Z-axis	R-axis
Axis specifications	Arm length	100 mm	150 mm	150 mm	-
	Rotation angle	+/-140 °	+/-144 °	-	+/-360 °
AC servo motor output		200 W	150 W	50 W	100 W
Deceleration mechanism	Speed reducer	Harmonic drive	Harmonic drive	Ball screw	Harmonic drive
	Transmission method	Direct-coupled			
	Motor to speed reducer Speed reducer to output	Direct-coupled			
Repeatability <sup>Note 1</sup>	+/-0.01 mm		+/-0.01 mm	+/-0.004 °	
Maximum speed	4.5 m/sec		1.1 m/sec	1020 °/sec	
Maximum payload	5 kg (Standard specification), 4 kg (Option specifications <sup>Note 4</sup> )				
Standard cycle time: with 2kg payload <sup>Note 2</sup>	0.49 sec				
R-axis tolerable moment of inertia <sup>Note 3</sup>	0.05 kgm <sup>2</sup> (0.5 kgfcm <sup>2</sup> )				
User wiring	0.2 sq × 10 wires				
User tubing (Outer diameter)	φ 4 × 3				
Travel limit	1.Soft limit 2.Mechanical stopper (X,Y,Z axis)				
Robot cable length	Standard: 3.5 m Option: 5 m, 10 m				
Weight	18.5 kg				

Note 1. This is the value at a constant ambient temperature. (X,Y axes)  
 Note 2. When reciprocating 300mm in horizontal and 25mm in vertical directions.  
 Note 3. There are limits to acceleration coefficient settings. See P.537.  
 Note 4. Maximum payload of option specifications (with tool flange attached or with user wiring and tubing routed through spline shaft) is 4kg.

## Controller

Controller	Power capacity (VA)	Operation method
RCX340 RCX240S	1000	Programming / I/O point trace / Remote command / Operation using RS-232C communication

Note. "Harmonic" and "Harmonic drive" are the registered trademarks of Harmonic Drive Systems Inc.  
 Note. The movement range can be limited by changing the positions of X and Y axis mechanical stoppers. (The movement range is set to the maximum at the time of shipment.)  
 See our robot manuals (installation manuals) for detailed information.  
 Note. To set the standard coordinates with high accuracy, use a standard coordinate setting jig (option). Refer to the user's manual (installation manual) for more details.

Our robot manuals (installation manuals) can be downloaded from our website at the address below:  
<http://global.yamaha-motor.com/business/robot/>

## YK250XG

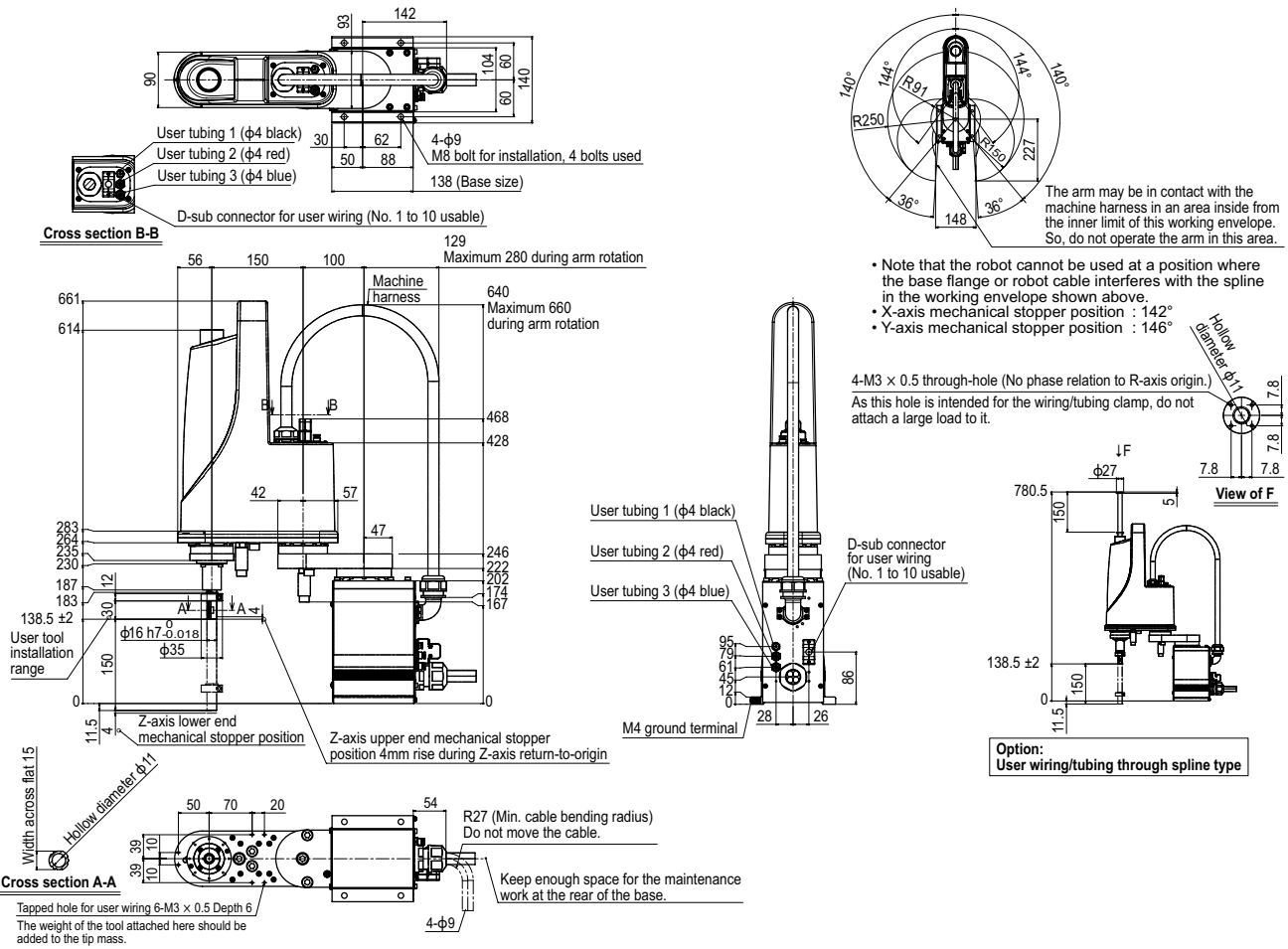

APPLICATION  
 Linear conveyor modules  
 LCM100  
 Compact single-axis robots  
 TRANSERVO  
 Single-axis robots  
 FLIP-X  
 Linear motor single-axis robots  
 PHASER  
 Cartesian robots  
 X-Y-X  
 SCARA robots  
 YK-X  
 Pick & place robots  
 YP-X  
 CLEAN  
 CONTROLLER INFORMATION  
 Orbit / Tiry type  
 Small type  
 Large type  
 Inverse type  
 Walk-mount / Inverse type  
 Dust-proof & drip-proof type

## YK250XG Tool flange mount type

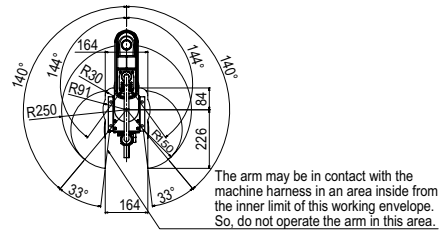
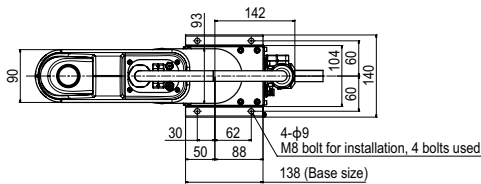

The arm may be in contact with the machine harness in an area inside from the inner limit of this working envelope. So, do not operate the arm in this area.

- Note that the robot cannot be used at a position where the base flange or robot cable interferes with the tool flange in the working envelope shown above.
- X-axis mechanical stopper position : 142°
- Y-axis mechanical stopper position : 146°

4-M3 x 0.5 through-hole (No phase relation to R-axis origin.)  
As this hole is intended for the wiring/tubing clamp, do not attach a large load to it.

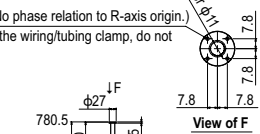
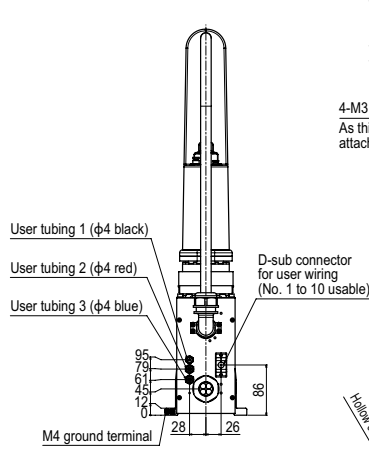
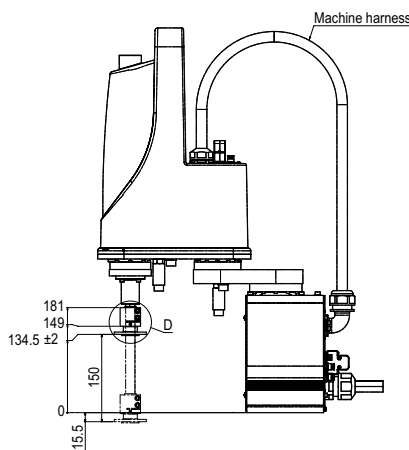
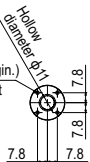

Option:  
User wiring/tubing through spline type

Tapped hole for user wiring 6-M3 x 0.5 Depth 6  
The weight of the tool attached here should be added to the tip mass.

R27 (Min. cable bending radius)  
Do not move the cable.  
Keep enough space for the maintenance work at the rear of the base.

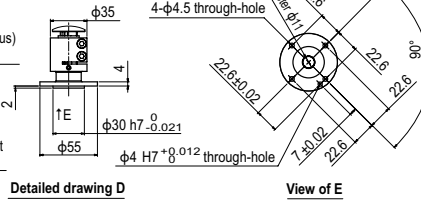

# YK350XG

Standard type: Small type

- Arm length 350mm
- Maximum payload 5kg

## Ordering method

**YK350XG - 150**

Model	Z axis stroke	Tool flange	Hollow shaft	Cable
	150: 150mm	No entry: None F: With tool flange	No entry: None S: With hollow shaft	3L: 3.5m 5L: 5m 10L: 10m

**RCX340-4**

Controller / Number of controllable axes	Safety standard	Option A (OP.A)	Option B (OP.B)	Option C (OP.C)	Option D (OP.D)	Option E (OP.E)	Absolute battery

Specify various controller setting items. RCX340 ▶ **P.508**

**RCX240S**

Controller	CE Marking	Expansion I/O	Network option	iVY System	Gripper	Battery
						BB

Specify various controller setting items. RCX240/RCX240S ▶ **P.495**

## Specifications

		X-axis	Y-axis	Z-axis	R-axis
<b>Axis specifications</b>	Arm length	200 mm	150 mm	150 mm	-
	Rotation angle	+/-140 °	+/-144 °	-	+/-360 °
<b>AC servo motor output</b>		200 W	150 W	50 W	100 W
<b>Deceleration mechanism</b>	Speed reducer	Harmonic drive	Harmonic drive	Ball screw	Harmonic drive
	Transmission method	Direct-coupled			
	Motor to speed reducer Speed reducer to output	Direct-coupled			
<b>Repeatability</b> <sup>Note 1</sup>		+/-0.01 mm		+/-0.01 mm	+/-0.004 °
<b>Maximum speed</b>		5.6 m/sec		1.1 m/sec	1020 °/sec
<b>Maximum payload</b>		5 kg (Standard specification), 4 kg (Option specifications <sup>Note 4</sup> )			
<b>Standard cycle time: with 2kg payload</b> <sup>Note 2</sup>		0.49 sec			
<b>R-axis tolerable moment of inertia</b> <sup>Note 3</sup>		0.05 kgm <sup>2</sup> (0.5 kgfcm <sup>2</sup> )			
<b>User wiring</b>		0.2 sq × 10 wires			
<b>User tubing (Outer diameter)</b>		φ 4 × 3			
<b>Travel limit</b>		1. Soft limit 2. Mechanical stopper (X,Y,Z axis)			
<b>Robot cable length</b>		Standard: 3.5 m Option: 5 m, 10 m			
<b>Weight</b>		19 kg			

Note 1. This is the value at a constant ambient temperature. (X,Y axes)

Note 2. When reciprocating 300mm in horizontal and 25mm in vertical directions.

Note 3. There are limits to acceleration coefficient settings. See P.537.

Note 4. Maximum payload of option specifications (with tool flange attached or with user wiring and tubing routed through spline shaft) is 4kg.

## Controller

Controller	Power capacity (VA)	Operation method
RCX340 RCX240S	1000	Programming / I/O point trace / Remote command / Operation using RS-232C communication

Note. "Harmonic" and "Harmonic drive" are the registered trademarks of Harmonic Drive Systems Inc.

Note. The movement range can be limited by changing the positions of X and Y axis mechanical stoppers. (The movement range is set to the maximum at the time of shipment.)

See our robot manuals (installation manuals) for detailed information.

Note. To set the standard coordinates with high accuracy, use a standard coordinate setting jig (option). Refer to the user's manual (installation manual) for more details.

Our robot manuals (installation manuals) can be downloaded from our website at the address below:  
<http://global.yamaha-motor.com/business/robot/>

## YK350XG

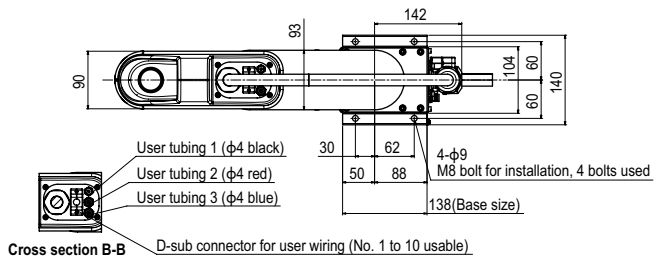

Cross section B-B D-sub connector for user wiring (No. 1 to 10 usable)

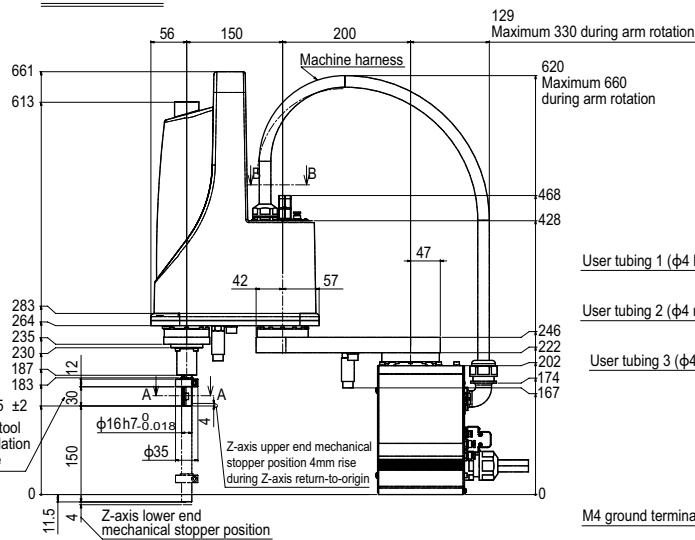

Cross section A-A

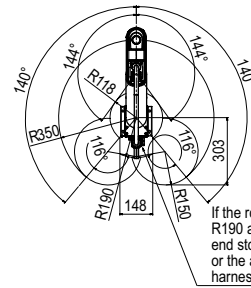

• Note that the robot cannot be used at a position where the base flange or robot cable interferes with the spline in the working envelope shown above.  
• X-axis mechanical stopper position : 142°  
• Y-axis mechanical stopper position : 146°

4-M3 × 0.5 through-hole (No phase relation to R-axis origin.)  
As this hole is intended for the wiring/tubing clamp, do not attach a large load to it.

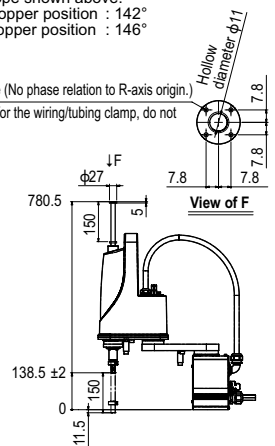

Option: User wiring/tubing through spline type

Keep enough space for the maintenance work at the rear of the base.

Tapped hole for user wiring 6-M3 × 0.5 Depth 6 4-φ9  
The weight of the tool attached here should be added to the tip mass.



## YK350XG Tool flange mount type

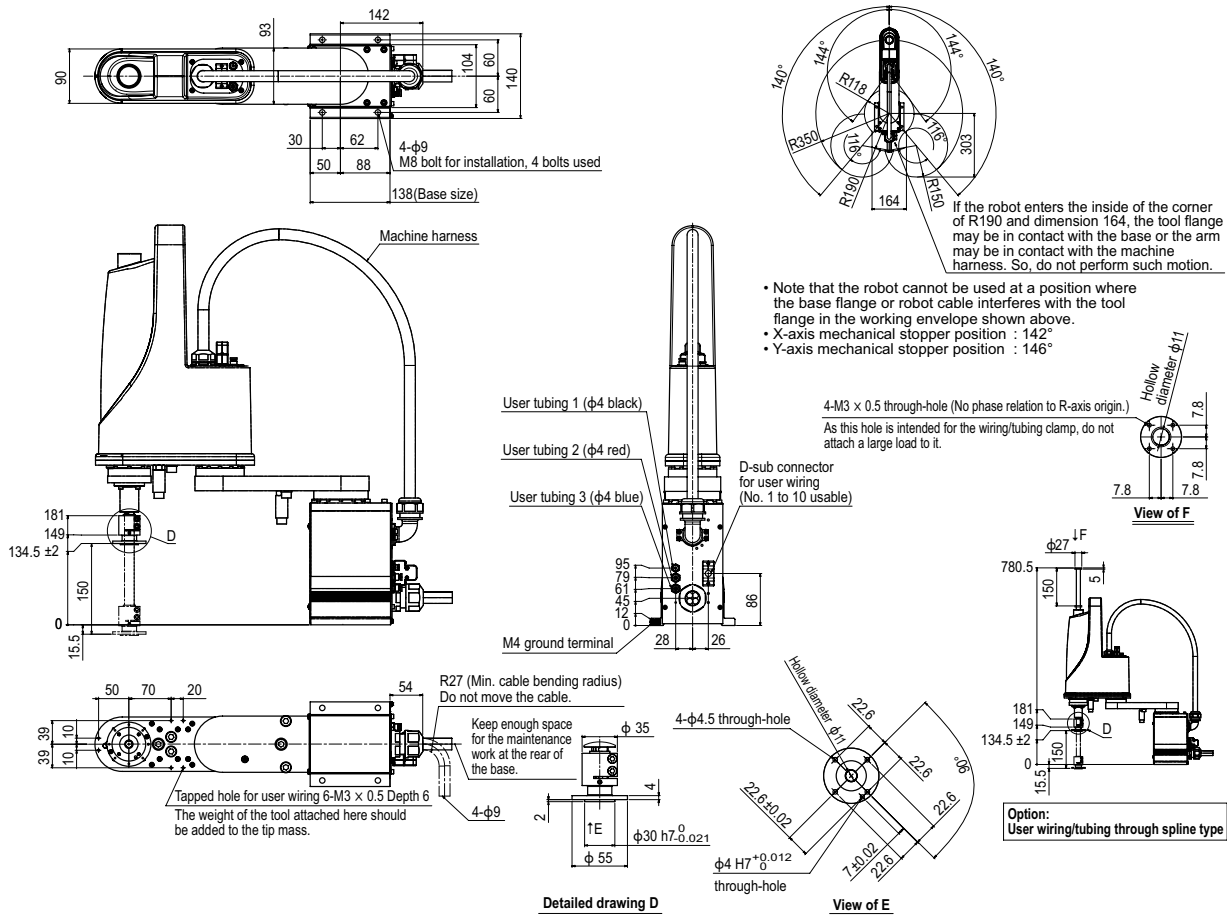

# YK400XG

Standard type: Small type

- Arm length 400mm
- Maximum payload 5kg

## Ordering method

**YK400XG - 150**

<b>Model</b>	<b>Z axis stroke</b> 150: 150mm	<b>Tool flange</b> No entry: None F: With tool flange	<b>Hollow shaft</b> No entry: None S: With hollow shaft	<b>Cable</b> 3L: 3.5m 5L: 5m 10L: 10m
--------------	------------------------------------	---	---	--

**RCX340-4**

<b>Controller / Number of controllable axes</b>	<b>Safety standard</b>	<b>Option A (OP.A)</b>	<b>Option B (OP.B)</b>	<b>Option C (OP.C)</b>	<b>Option D (OP.D)</b>	<b>Option E (OP.E)</b>	<b>Absolute battery</b>
---	------------------------	------------------------	------------------------	------------------------	------------------------	------------------------	-------------------------

Specify various controller setting items. RCX340 ▶ **P.508**

**RCX240S**

<b>Controller</b>	<b>CE Marking</b>	<b>Expansion I/O</b>	<b>Network option</b>	<b>IVY System</b>	<b>Gripper</b>	<b>Battery</b>
-------------------	-------------------	----------------------	-----------------------	-------------------	----------------	----------------

Specify various controller setting items. RCX240/RCX240S ▶ **P.495**

## Specifications

		X-axis	Y-axis	Z-axis	R-axis
<b>Axis specifications</b>	<b>Arm length</b>	250 mm	150 mm	150 mm	-
	<b>Rotation angle</b>	+/-140 °	+/-144 °	-	+/-360 °
<b>AC servo motor output</b>		200 W	150 W	50 W	100 W
<b>Deceleration mechanism</b>	<b>Speed reducer</b>	Harmonic drive	Harmonic drive	Ball screw	Harmonic drive
	<b>Transmission method</b>	Direct-coupled			
	<b>Motor to speed reducer</b> <b>Speed reducer to output</b>	Direct-coupled			
<b>Repeatability</b> <sup>Note 1</sup>	+/-0.01 mm		+/-0.01 mm	+/-0.004 °	
<b>Maximum speed</b>		6.1 m/sec		1.1 m/sec	1020 °/sec
<b>Maximum payload</b>		5 kg (Standard specification), 4 kg (Option specifications <sup>Note 4</sup> )			
<b>Standard cycle time: with 2kg payload</b> <sup>Note 2</sup>		0.49 sec			
<b>R-axis tolerable moment of inertia</b> <sup>Note 3</sup>		0.05 kgm <sup>2</sup> (0.5 kgfcm <sup>2</sup> )			
<b>User wiring</b>		0.2 sq × 10 wires			
<b>User tubing (Outer diameter)</b>		φ 4 × 3			
<b>Travel limit</b>		1.Soft limit 2.Mechanical stopper (X,Y,Z axis)			
<b>Robot cable length</b>		Standard: 3.5 m Option: 5 m, 10 m			
<b>Weight</b>		19.5 kg			

Note 1. This is the value at a constant ambient temperature. (X,Y axes)  
 Note 2. When reciprocating 300mm in horizontal and 25mm in vertical directions.  
 Note 3. There are limits to acceleration coefficient settings. See P.538.  
 Note 4. Maximum payload of option specifications (with tool flange attached or with user wiring and tubing routed through spline shaft) is 4kg.

## Controller

Controller	Power capacity (VA)	Operation method
RCX340 RCX240S	1000	Programming / I/O point trace / Remote command / Operation using RS-232C communication

Note. "Harmonic" and "Harmonic drive" are the registered trademarks of Harmonic Drive Systems Inc.  
 Note. The movement range can be limited by changing the positions of X and Y axis mechanical stoppers. (The movement range is set to the maximum at the time of shipment.)  
 See our robot manuals (installation manuals) for detailed information.  
 Note. To set the standard coordinates with high accuracy, use a standard coordinate setting jig (option). Refer to the user's manual (installation manual) for more details.

Our robot manuals (installation manuals) can be downloaded from our website at the address below:  
<http://global.yamaha-motor.com/business/robot/>

## YK400XG

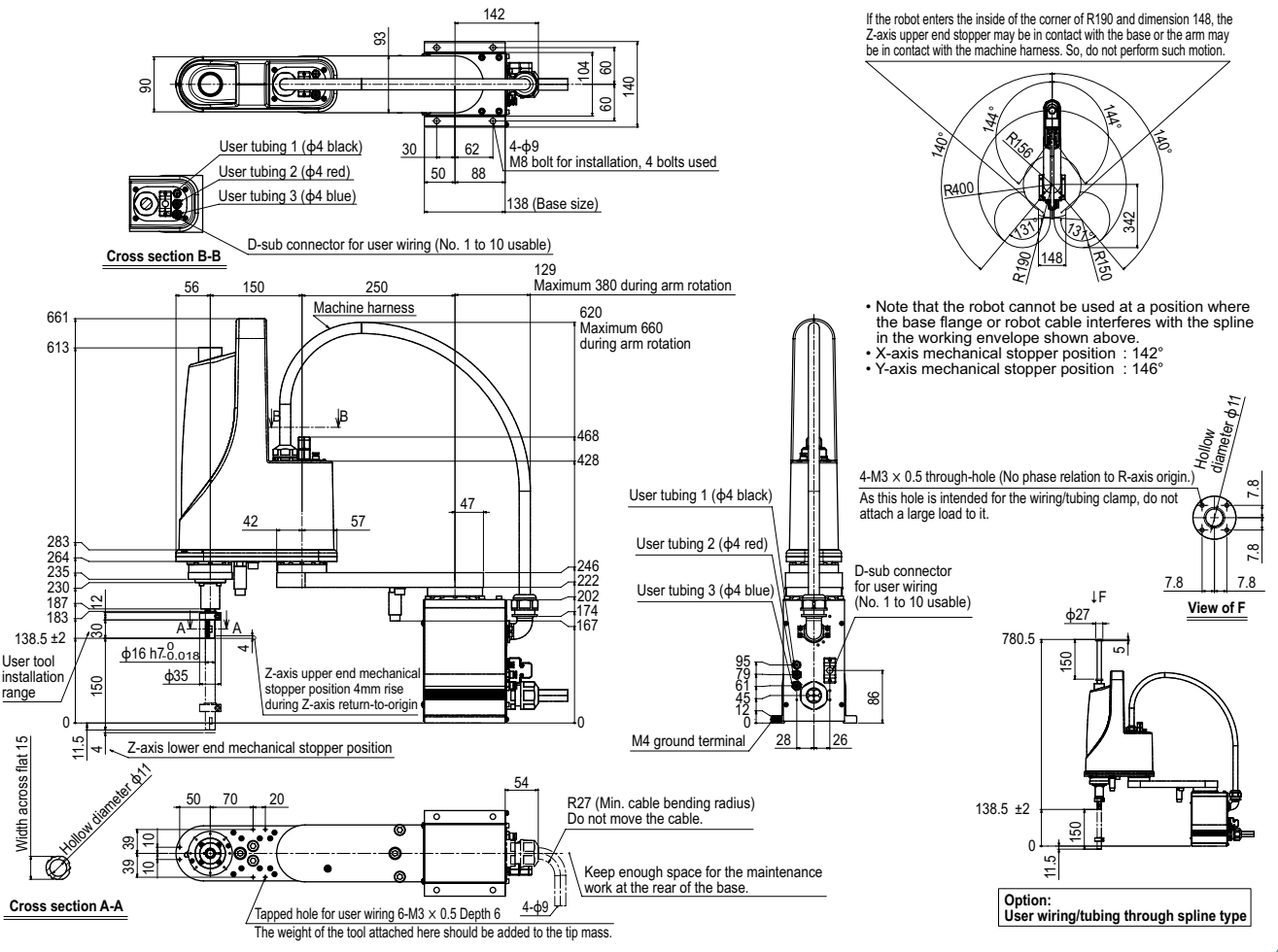

APPLICATION  
 Linear conveyor/ modules  
 LCM100  
 TRANSEURO  
 Compact single-axis robots  
 Single-axis robots  
 FLIP-X  
 Linear motor single-axis robots  
 PHASER  
 Cartesian robots  
 X-Y-X  
 SCARA robots  
 YK-X  
 Pick & place robots  
 YP-X  
 CLEAN  
 CONTROLLER INFORMATION  
 Orbit / T/Tv type  
 Small type  
 Large type  
 Inverse type  
 Walk-mount / Inverse type  
 Dust-proof & drip-proof type

- APPLICATION
- Linear conveyor modules  
LCM100
- Compact single-axis robots  
TRANSEVO
- Single-axis robots  
FLIP-X
- Linear motor single-axis robots  
PHASER
- Cartesian robots  
XY-X
- SCARA robots  
YK-X
- Pick & place robots  
YP-X
- CLEAN
- CONTROLLER INFORMATION
- Orbit/Tiny
- Small type
- Large type
- Wall-mount / Inverse type
- Dust-proof & drip-proof type

## YK400XG Tool flange mount type

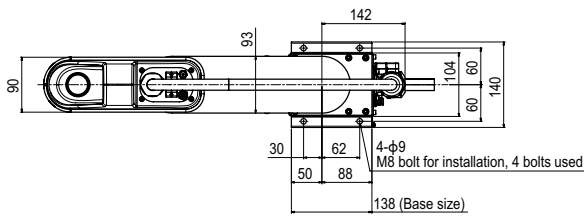

If the robot enters the inside of the corner of R190 and dimension 148, the tool flange may be in contact with the base or the arm may be in contact with the machine harness. So, do not perform such motion.

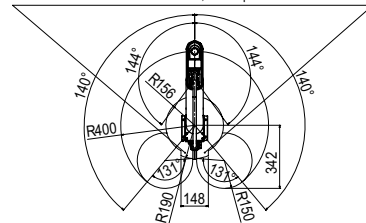

- Note that the robot cannot be used at a position where the base flange or robot cable interferes with the tool flange in the working envelope shown above.
- X-axis mechanical stopper position : 142°
- Y-axis mechanical stopper position : 146°

4-M3 x 0.5 through-hole (No phase relation to R-axis origin.)

As this hole is intended for the wiring/tubing clamp, do not attach a large load to it.

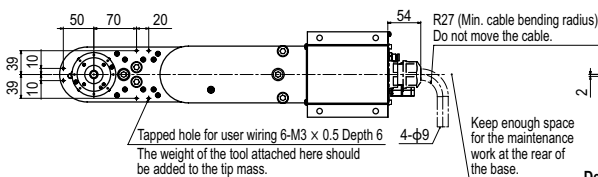
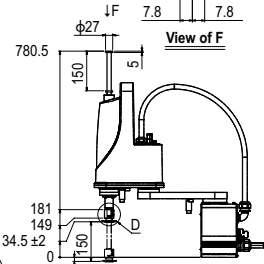
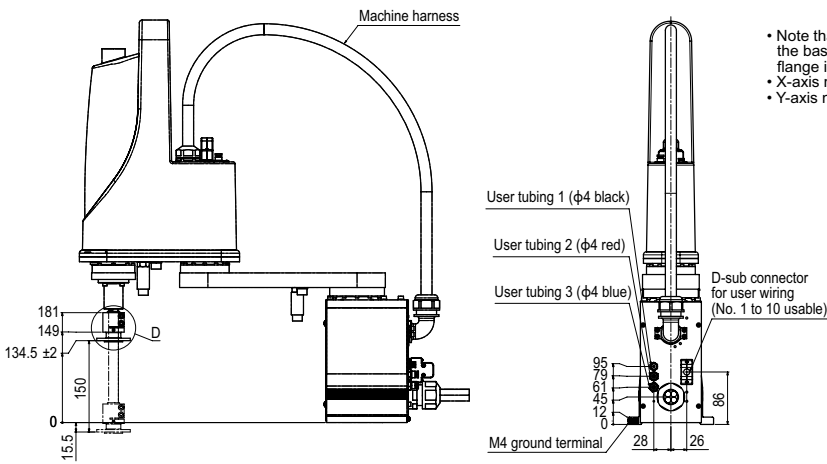
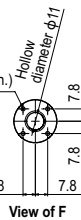

Detailed drawing D

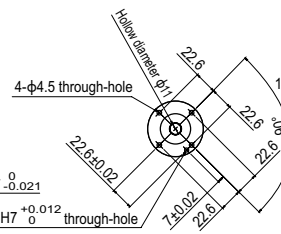

Option:  
User wiring/tubing through spline type

# YK400XR

Standard type: Small type

● LOW COST HIGH PERFORMANCE MODEL

- Arm length 400mm
- Maximum payload 3kg



## Ordering method

<b>YK400XR</b>		<b>150</b>			<b>RCX340-4</b>												
<b>Model</b>	<b>Return-to-origin method</b> S: Sensor T: Stroke end	<b>Z axis stroke</b>	<b>Hollow shaft</b> No entry: None S: With hollow shaft	<b>Cable</b> 3L: 3.5m 5L: 5m 10L: 10m	<b>Controller / Number of controllable axes</b>	<b>Safety standard</b>	<b>Option A (OP.A)</b>	<b>Option B (OP.B)</b>	<b>Option C (OP.C)</b>	<b>Option D (OP.D)</b>	<b>Option E (OP.E)</b>	<b>Absolute battery</b> 4: 4 pcs. 3: 3 pcs. 2: 2 pcs. 1: 1 pc. 0: 0 pc.					

Specify various controller setting items. RCX340 ▶ **P.508**

## Specifications

		X-axis	Y-axis	Z-axis	R-axis
<b>Axis specifications</b>	<b>Arm length</b>	225 mm	175 mm	150 mm	-
	<b>Rotation angle</b>	+/-132 °	+/-150 °	-	+/-360 °
<b>AC servo motor output</b>		200 W	100 W	100 W	100 W
<b>Deceleration mechanism</b>	<b>Speed reducer</b>	Harmonic drive	Harmonic drive	Ball screw	Belt speed reduction
	<b>Transmission method</b>	Direct-coupled		Timing belt	
	<b>Motor to speed reducer</b>	Direct-coupled		Timing belt	
<b>Speed reducer to output</b>	Direct-coupled		Timing belt		
<b>Repeatability</b> <sup>Note 1</sup>		+/-0.01 mm		+/-0.01 mm	+/-0.01 °
<b>Maximum speed</b>		6 m/sec		1.1 m/sec	2600 °/sec
<b>Maximum payload</b>		3 kg (Standard specification), 2 kg (Option specifications <sup>Note 4</sup> )			
<b>Standard cycle time: with 2kg payload</b> <sup>Note 2</sup>		0.45 sec			
<b>R-axis tolerable moment of inertia</b> <sup>Note 3</sup>		0.05 kgm <sup>2</sup> (0.5 kgfcm <sup>2</sup> )			
<b>User wiring</b>		0.2 sq × 10 wires			
<b>User tubing (Outer diameter)</b>		φ 4 × 3			
<b>Travel limit</b>		1. Soft limit 2. Mechanical stopper (X,Y,Z axis)			
<b>Robot cable length</b>		Standard: 3.5 m Option: 5 m, 10 m			
<b>Weight</b>		17 kg			

Note 1. This is the value at a constant ambient temperature. (X,Y axes)

Note 2. When reciprocating 300mm in horizontal and 25mm in vertical directions and performing the coarse positioning arch operation.

Note 3. It is necessary to input the moment of inertia in the actual operating environment.

Note 4. Maximum payload of option specifications (with user wiring/tubing through spline type) is 2kg.

## Controller

Controller	Power capacity (VA)	Operation method
RCX340	1000	Programming / Remote command / Operation using RS-232C communication

Note. "Harmonic" and "Harmonic drive" are the registered trademarks of Harmonic Drive Systems Inc.

Note. The movement range can be restricted by adding the X- and Y-axis mechanical stoppers. (The maximum movement range was set at shipment.)

See our robot manuals (installation manuals) for detailed information.

Note. To set the standard coordinates with high accuracy, use a standard coordinate setting jig (option). Refer to the user's manual (installation manual) for more details.

Our robot manuals (installation manuals) can be downloaded from our website at the address below:  
<http://global.yamaha-motor.com/business/robot/>

## YK400XR

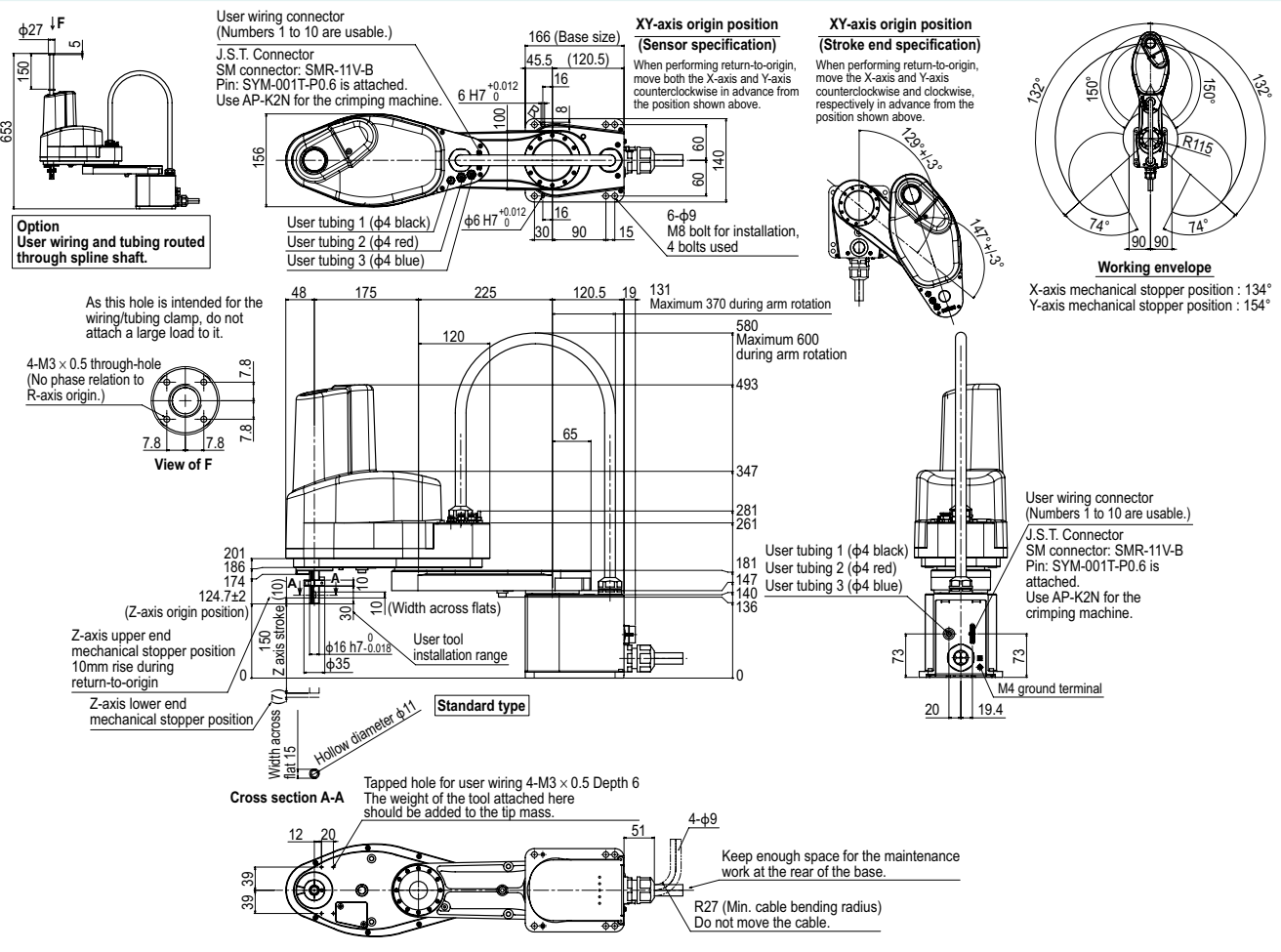

APPLICATION  
Linear conveyor  
modules  
LCM100

TRANSERVO  
Compact  
single-axis robots

FLIP-X  
Single-axis robots

PHASER  
Linear motor  
single-axis robots

XX-X  
Cartesian  
robots

YK-X  
SCARA  
robots

YP-X  
Pick & place  
robots

CLEAN

CONTROLLER INFORMATION

Orbit / Triv  
type

Small type

Large type

Walk-mount /  
inverse type

Dust-proof  
& drip-proof  
type

# YK500XGL

Standard type: Medium type



- Arm length 500mm
- Maximum payload 5kg

## Ordering method

**YK500XGL - 150**

<b>Model</b>	Z axis stroke 150: 150mm	<b>Tool flange</b> No entry: None F: With tool flange	<b>Hollow shaft</b> No entry: None S: With hollow shaft	<b>Cable</b> 3L: 3.5m 5L: 5m 10L: 10m
--------------	-----------------------------	---	---	--

**RCX340-4**

<b>Controller / Number of controllable axes</b>	<b>Safety standard</b>	<b>Option A (OP.A)</b>	<b>Option B (OP.B)</b>	<b>Option C (OP.C)</b>	<b>Option D (OP.D)</b>	<b>Option E (OP.E)</b>	<b>Absolute battery</b>
---	------------------------	------------------------	------------------------	------------------------	------------------------	------------------------	-------------------------

**RCX240S**

<b>Controller</b>	<b>CE Marking</b>	<b>Expansion I/O</b>	<b>Network option</b>	<b>iVY System</b>	<b>Gripper</b>	<b>Battery</b>
-------------------	-------------------	----------------------	-----------------------	-------------------	----------------	----------------

Specify various controller setting items. RCX340 ▶ **P.508**  
Specify various controller setting items. RCX240/RCX240S ▶ **P.495**

## Specifications

Axis specifications	Arm length	X-axis	Y-axis	Z-axis	R-axis
Rotation angle		250 mm	250 mm	150 mm	-
		+/-140 °	+/-144 °	-	+/-360 °
AC servo motor output		200 W	150 W	50 W	100 W
Deceleration mechanism	Speed reducer	Harmonic drive	Harmonic drive	Ball screw	Harmonic drive
	Transmission method	Direct-coupled			
	Motor to speed reducer	Direct-coupled			
	Speed reducer to output	Direct-coupled			
Repeatability <sup>Note 1</sup>		+/-0.01 mm		+/-0.01 mm	+/-0.004 °
Maximum speed		5.1 m/sec		1.1 m/sec	1020 °/sec
Maximum payload		5 kg (Standard specification), 4 kg (Option specifications <sup>Note 4</sup> )			
Standard cycle time: with 2kg payload <sup>Note 2</sup>		0.59 sec			
R-axis tolerable moment of inertia <sup>Note 3</sup>		0.05 kgm <sup>2</sup> (0.5 kgfcm <sup>2</sup> )			
User wiring		0.2 sq x 10 wires			
User tubing (Outer diameter)		φ 4 x 3			
Travel limit		1.Soft limit 2.Mechanical stopper (X,Y,Z axis)			
Robot cable length		Standard: 3.5 m Option: 5 m, 10 m			
Weight		21 kg			

Note 1. This is the value at a constant ambient temperature. (X,Y axes)  
Note 2. When reciprocating 300mm in horizontal and 25mm in vertical directions.  
Note 3. There are limits to acceleration coefficient settings. See P.538.  
Note 4. Maximum payload of option specifications (with tool flange attached or with user wiring and tubing routed through spline shaft) is 4kg.

## Controller

Controller	Power capacity (VA)	Operation method
RCX340 RCX240S	1000	Programming / I/O point trace / Remote command / Operation using RS-232C communication

Note. "Harmonic" and "Harmonic drive" are the registered trademarks of Harmonic Drive Systems Inc.  
Note. The movement range can be limited by changing the positions of X and Y axis mechanical stoppers. (The movement range is set to the maximum at the time of shipment.)  
See our robot manuals (installation manuals) for detailed information.  
Note. To set the standard coordinates with high accuracy, use a standard coordinate setting jig (option). Refer to the user's manual (installation manual) for more details.

Our robot manuals (installation manuals) can be downloaded from our website at the address below:  
<http://global.yamaha-motor.com/business/robot/>

## YK500XGL

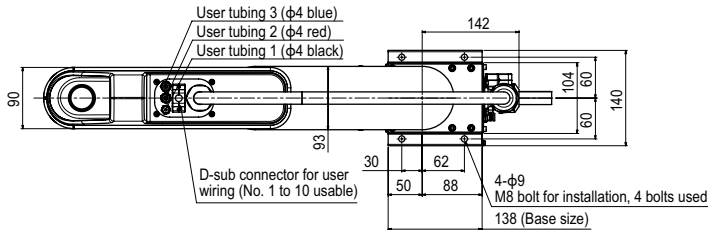

If the robot enters the inside of the corner of R200 and R250, the arm may be in contact with the machine harness. So, do not perform such motion.

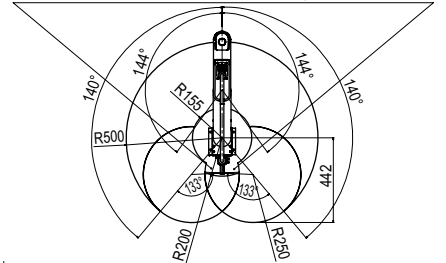

- Note that the robot cannot be used at a position where the base flange or robot cable interferes with the spline in the working envelope shown above.
- X-axis mechanical stopper position : 142°
- Y-axis mechanical stopper position : 146°

4-M3 x 0.5 through-hole (No phase relation to R-axis origin.)  
As this hole is intended for the wiring/tubing clamp, do not attach a large load to it.

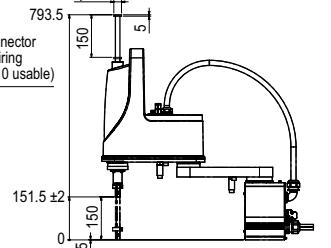
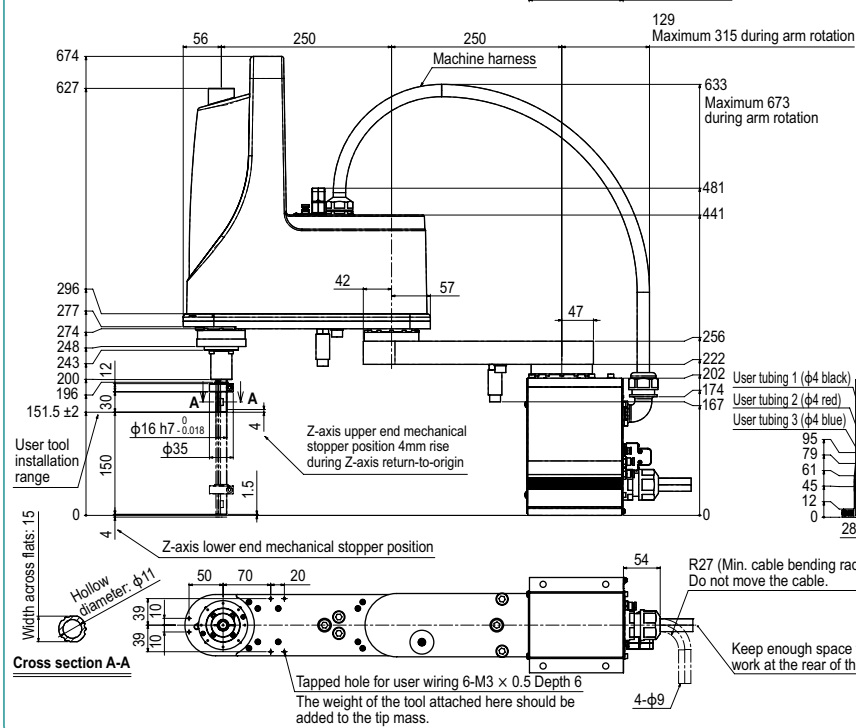
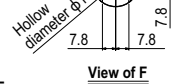

YK500XGL Tool flange mount type

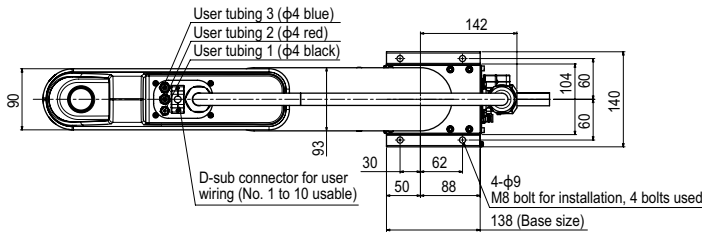

If the robot enters the inside of corners of R200 and R250, the arm may be in contact with the machine harness. So, do not perform such motion.

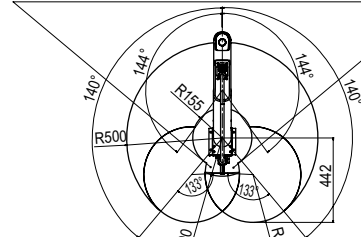

- Note that the robot cannot be used at a position where the base flange or robot cable interferes with the tool flange in the working envelope shown above.
- X-axis mechanical stopper position : 142°
- Y-axis mechanical stopper position : 146°

4-M3 × 0.5 through-hole  
(No phase relation to R-axis origin.)  
As this hole is intended for the wiring/tubing clamp, do not attach a large load to it.

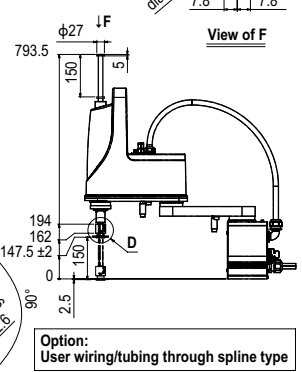
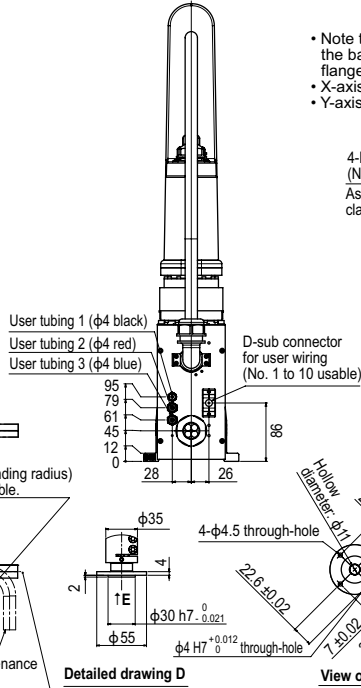
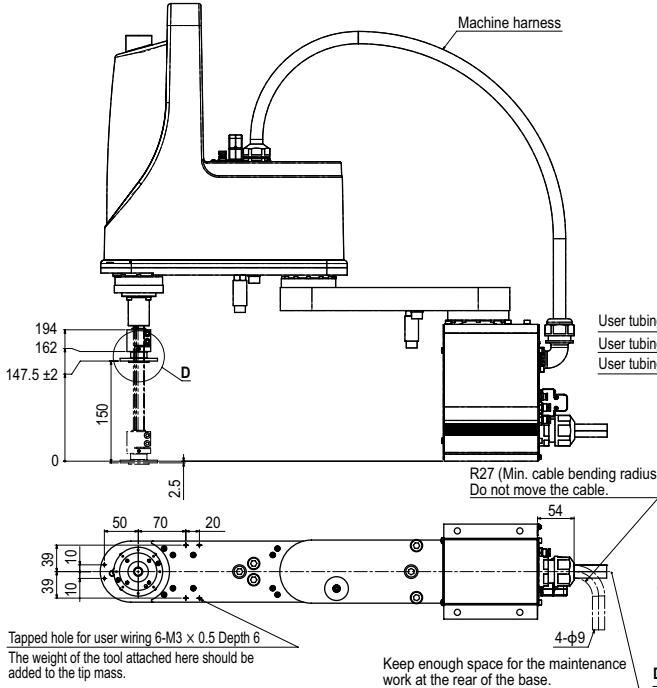
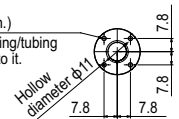

# YK500XG

Standard type: Medium type

- Arm length 500mm
- Maximum payload 10kg

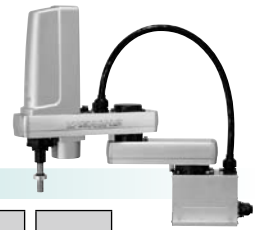

## Ordering method

**YK500XG**

<b>Model</b>	<b>Z axis stroke</b>	<b>Tool flange</b>	<b>Cable</b>
	200: 200mm 300: 300mm	No entry: None F: With tool flange	3L: 3.5m 5L: 5m 10L: 10m

**RCX340-4**

<b>Controller / Number of controllable axes</b>	<b>Safety standard</b>	<b>Option A (OP.A)</b>	<b>Option B (OP.B)</b>	<b>Option C (OP.C)</b>	<b>Option D (OP.D)</b>	<b>Option E (OP.E)</b>	<b>Absolute battery</b>
---	------------------------	------------------------	------------------------	------------------------	------------------------	------------------------	-------------------------

Specify various controller setting items. RCX340 ▶ **P.508**

**RCX240**

<b>Controller</b>	<b>CE Marking</b>	<b>Regenerative unit</b>	<b>Expansion I/O</b>	<b>Network option</b>	<b>IVY System</b>	<b>Gripper</b>	<b>Battery</b>
-------------------	-------------------	--------------------------	----------------------	-----------------------	-------------------	----------------	----------------

Specify various controller setting items. RCX240/RCX240S ▶ **P.495**

## Specifications

		X-axis	Y-axis	Z-axis	R-axis
<b>Axis specifications</b>	<b>Arm length</b>	200 mm	300 mm	200 mm 300 mm	—
	<b>Rotation angle</b>	+/-130 °	+/-145 °	—	+/-360 °
<b>AC servo motor output</b>		400 W	200 W	200 W	200 W
<b>Deceleration mechanism</b>	<b>Speed reducer</b>	Harmonic drive	Harmonic drive	Ball screw	Harmonic drive
	<b>Transmission method</b>	Direct-coupled			
	<b>Motor to speed reducer</b>	Direct-coupled			
	<b>Speed reducer to output</b>	Direct-coupled			
<b>Repeatability</b> <small>Note 1</small>		+/-0.01 mm	+/-0.01 mm	+/-0.01 mm	+/-0.004 °
<b>Maximum speed</b>		7.6 m/sec	2.3 m/sec	1.7 m/sec	1700 °/sec
<b>Maximum payload</b>		10 kg			
<b>Standard cycle time: with 2kg payload</b> <small>Note 2</small>		0.45 sec			
<b>R-axis tolerable moment of inertia</b> <small>Note 3</small>		0.30 kgm <sup>2</sup>			
<b>User wiring</b>		0.2 sq × 20 wires			
<b>User tubing (Outer diameter)</b>		φ 6 × 3			
<b>Travel limit</b>		1.Soft limit 2.Mechanical stopper (X,Y,Z axis)			
<b>Robot cable length</b>		Standard: 3.5 m Option: 5 m, 10 m			
<b>Weight</b>		30 kg			

Note 1. This is the value at a constant ambient temperature. (X,Y axes)  
 Note 2. When reciprocating 300mm in horizontal and 25mm in vertical directions.  
 Note 3. There are limits to acceleration coefficient settings. See P.539.

## Controller

Controller	Power capacity (VA)	Operation method
RCX340 RCX240-R3	1700	Programming / I/O point trace / Remote command / Operation using RS-232C communication

Note. "Harmonic" and "Harmonic drive" are the registered trademarks of Harmonic Drive Systems Inc.

Note. The movement range can be limited by changing the positions of X and Y axis mechanical stoppers. (The movement range is set to the maximum at the time of shipment.)

See our robot manuals (installation manuals) for detailed information.

Note. To set the standard coordinates with high accuracy, use a standard coordinate setting jig (option). Refer to the user's manual (installation manual) for more details.

Our robot manuals (installation manuals) can be downloaded from our website at the address below:  
<http://global.yamaha-motor.com/business/robot/>

## YK500XG

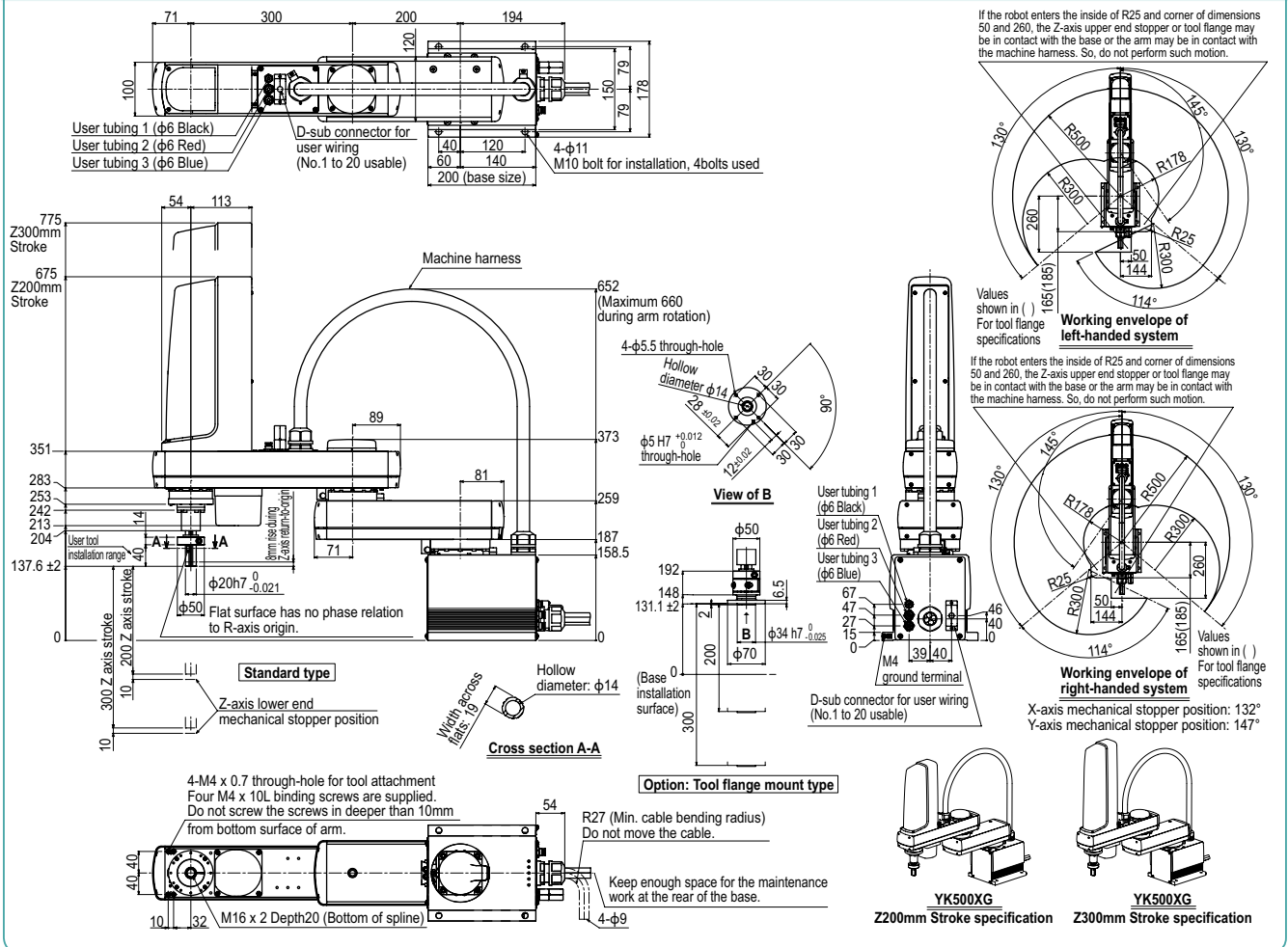

# YK600XGL

Standard type: Medium type

- Arm length 600mm
- Maximum payload 5kg



## Ordering method

**YK600XGL - 150**

<b>Model</b>	<b>Z axis stroke</b> 150: 150mm	<b>Tool flange</b> No entry: None F: With tool flange	<b>Hollow shaft</b> No entry: None S: With hollow shaft	<b>Cable</b> 3L: 3.5m 5L: 5m 10L: 10m
--------------	------------------------------------	---	---	--

**RCX340-4**

<b>Controller / Number of controllable axes</b>	<b>Safety standard</b>	<b>Option A (OP.A)</b>	<b>Option B (OP.B)</b>	<b>Option C (OP.C)</b>	<b>Option D (OP.D)</b>	<b>Option E (OP.E)</b>	<b>Absolute battery</b>
---	------------------------	------------------------	------------------------	------------------------	------------------------	------------------------	-------------------------

Specify various controller setting items. RCX340 ▶ **P.508**

**RCX240S**

<b>Controller</b>	<b>CE Marking</b>	<b>Expansion I/O</b>	<b>Network option</b>	<b>IVY System</b>	<b>Gripper</b>	<b>Battery</b>
-------------------	-------------------	----------------------	-----------------------	-------------------	----------------	----------------

Specify various controller setting items. RCX240/RCX240S ▶ **P.495**

## Specifications

		X-axis	Y-axis	Z-axis	R-axis
<b>Axis specifications</b>	<b>Arm length</b>	350 mm	250 mm	150 mm	-
	<b>Rotation angle</b>	+/-140 °	+/-144 °	-	+/-360 °
<b>AC servo motor output</b>		200 W	150 W	50 W	100 W
<b>Deceleration mechanism</b>	<b>Speed reducer</b>	Harmonic drive	Harmonic drive	Ball screw	Harmonic drive
	<b>Transmission method</b>	Direct-coupled			
	<b>Motor to speed reducer</b> <b>Speed reducer to output</b>	Direct-coupled			
<b>Repeatability</b> <sup>Note 1</sup>	+/-0.01 mm		+/-0.01 mm	+/-0.004 °	
<b>Maximum speed</b>		4.9 m/sec		1.1 m/sec	1020 °/sec
<b>Maximum payload</b>		5 kg (Standard specification), 4 kg (Option specifications <sup>Note 4</sup> )			
<b>Standard cycle time: with 2kg payload</b> <sup>Note 2</sup>		0.63 sec			
<b>R-axis tolerable moment of inertia</b> <sup>Note 3</sup>		0.05 kgm <sup>2</sup> (0.5 kgfcm <sup>2</sup> )			
<b>User wiring</b>		0.2 sq × 10 wires			
<b>User tubing (Outer diameter)</b>		φ 4 × 3			
<b>Travel limit</b>		1. Soft limit 2. Mechanical stopper (X,Y,Z axis)			
<b>Robot cable length</b>		Standard: 3.5 m Option: 5 m, 10 m			
<b>Weight</b>		22 kg			

Note 1. This is the value at a constant ambient temperature. (X,Y axes)  
 Note 2. When reciprocating 300mm in horizontal and 25mm in vertical directions.  
 Note 3. There are limits to acceleration coefficient settings. See P.538.  
 Note 4. Maximum payload of option specifications (with tool flange attached or with user wiring and tubing routed through spline shaft) is 4kg.

## Controller

Controller	Power capacity (VA)	Operation method
RCX340 RCX240S	1000	Programming / I/O point trace / Remote command / Operation using RS-232C communication

Note. "Harmonic" and "Harmonic drive" are the registered trademarks of Harmonic Drive Systems Inc.  
 Note. The movement range can be limited by changing the positions of X and Y axis mechanical stoppers. (The movement range is set to the maximum at the time of shipment.)  
 See our robot manuals (installation manuals) for detailed information.  
 Note. To set the standard coordinates with high accuracy, use a standard coordinate setting jig (option). Refer to the user's manual (installation manual) for more details.

Our robot manuals (installation manuals) can be downloaded from our website at the address below:  
<http://global.yamaha-motor.com/business/robot/>

## YK600XGL

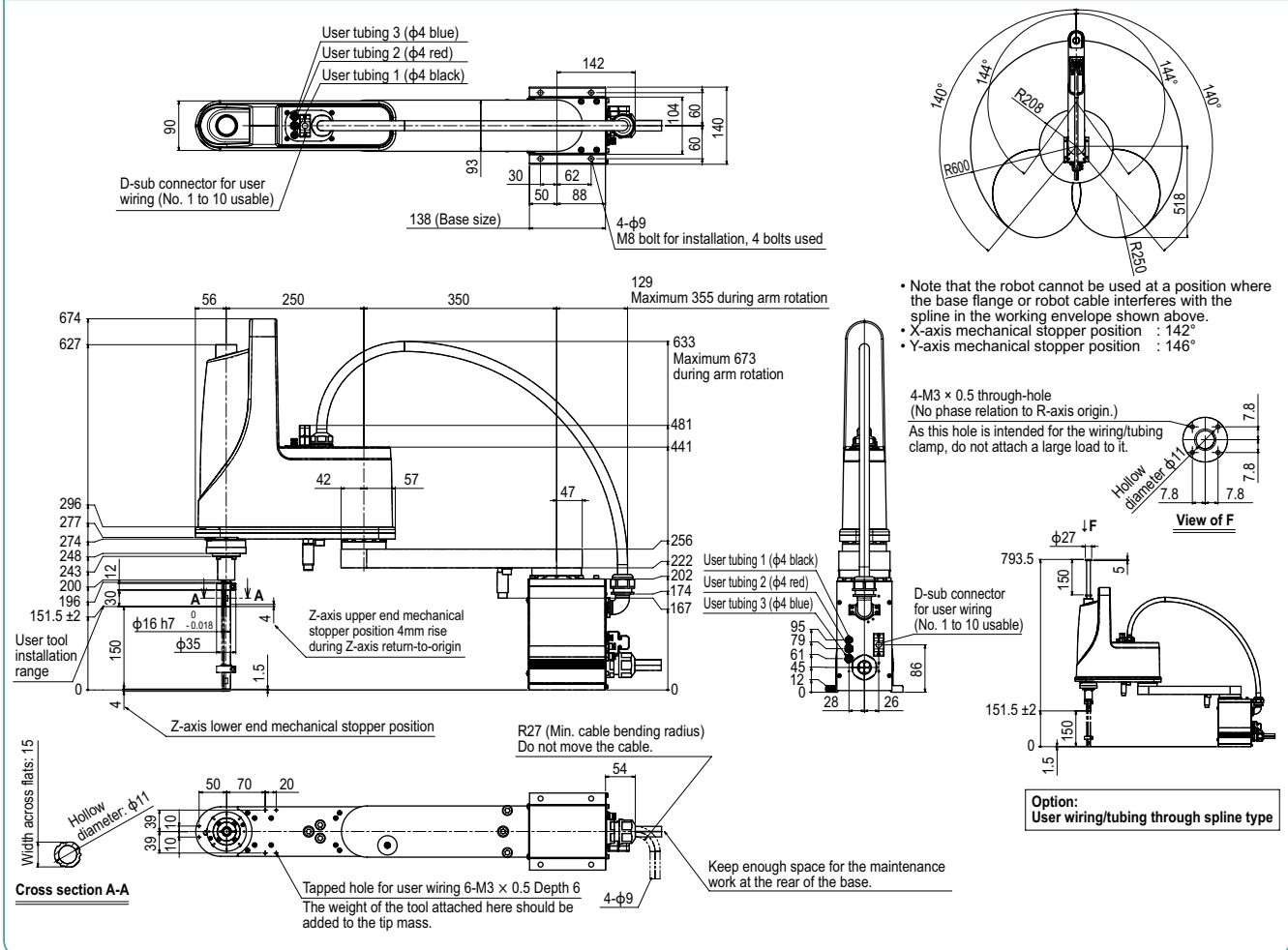

APPLICATION  
 Linear conveyor / modules  
 LCM100  
 TRANSEURO  
 Compact single-axis robots  
 Single-axis robots  
 FLIP-X  
 Linear motor single-axis robots  
 PHASER  
 Cartesian robots  
 XX-X  
 SCARA robots  
 YK-X  
 Pick & place robots  
 YP-X  
 CLEAN  
 CONTROLLER INFORMATION  
 Orbit / T/Try type  
 Medium type  
 Large type  
 Inverse type  
 Dust-proof & drip-proof type



## YK600XGL Tool flange mount type

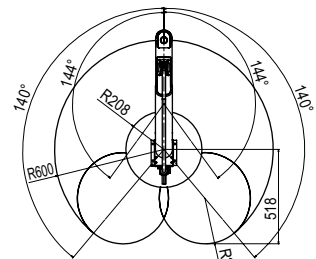
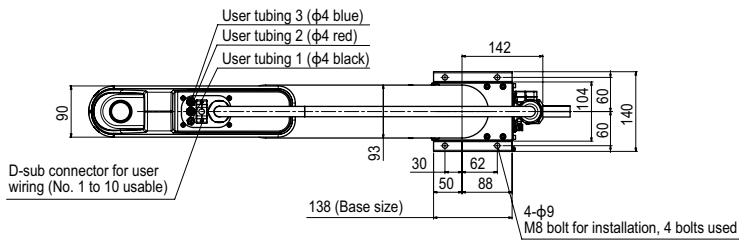

- Note that the robot cannot be used at a position where the base flange or robot cable interferes with the tool flange in the working envelope shown above.
- X-axis mechanical stopper position : 142°
- Y-axis mechanical stopper position : 146°

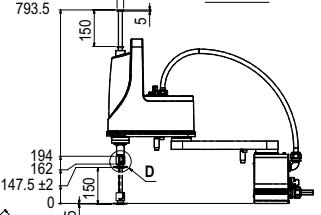
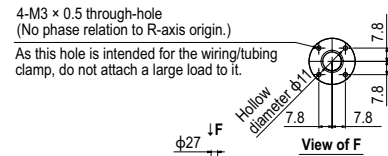
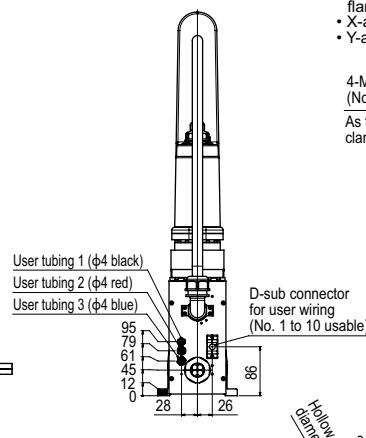
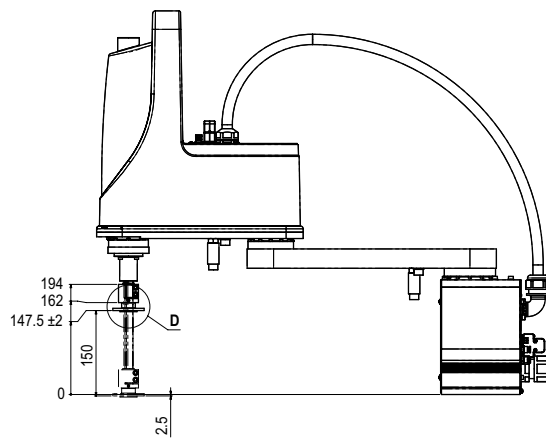

Option:  
User wiring/tubing through spline type

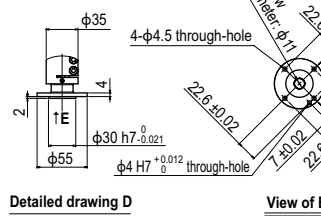
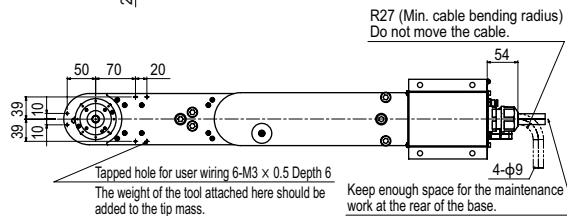

# YK600XG

Standard type: Medium type

- Arm length 600mm
- Maximum payload 10kg



## Ordering method

**YK600XG**

Model	Z axis stroke	Tool flange	Cable
	200: 200mm 300: 300mm	No entry: None F: With tool flange	3L: 3.5m 5L: 5m 10L: 10m

**RCX340-4**

Controller / Number of controllable axes	Safety standard	Option A (OP.A)	Option B (OP.B)	Option C (OP.C)	Option D (OP.D)	Option E (OP.E)	Absolute battery
--	-----------------	-----------------	-----------------	-----------------	-----------------	-----------------	------------------

Specify various controller setting items. RCX340 ▶ **P.508**

**RCX240**

Controller	CE Marking	Regenerative unit	Expansion I/O	Network option	IVY System	Gripper	Battery
------------	------------	-------------------	---------------	----------------	------------	---------	---------

Specify various controller setting items. RCX240/RCX240S ▶ **P.495**

## Specifications

		X-axis	Y-axis	Z-axis	R-axis
Axis specifications	Arm length	300 mm	300 mm	200 mm	300 mm
	Rotation angle	+/-130 °	+/-145 °	-	+/-360 °
AC servo motor output		400 W	200 W	200 W	200 W
Deceleration mechanism	Speed reducer	Harmonic drive	Harmonic drive	Ball screw	Harmonic drive
	Transmission method	Direct-coupled			
	Motor to speed reducer	Direct-coupled			
	Speed reducer to output	Direct-coupled			
Repeatability <sup>Note 1</sup>		+/-0.01 mm		+/-0.01 mm	+/-0.004 °
Maximum speed		8.4 m/sec		2.3 m/sec	1.7 m/sec
Maximum payload		10 kg			
Standard cycle time: with 2kg payload <sup>Note 2</sup>		0.46 sec			
R-axis tolerable moment of inertia <sup>Note 3</sup>		0.30 kgm <sup>2</sup>			
User wiring		0.2 sq x 20 wires			
User tubing (Outer diameter)		φ 6 x 3			
Travel limit		1.Soft limit 2.Mechanical stopper (X,Y,Z axis)			
Robot cable length		Standard: 3.5 m Option: 5 m, 10 m			
Weight		31 kg			

Note 1. This is the value at a constant ambient temperature. (X,Y axes)  
 Note 2. When reciprocating 300mm in horizontal and 25mm in vertical directions.  
 Note 3. There are limits to acceleration coefficient settings. See P.539.

## Controller

Controller	Power capacity (VA)	Operation method
RCX340 RCX240-R3	1700	Programming / I/O point trace / Remote command / Operation using RS-232C communication

Note. "Harmonic" and "Harmonic drive" are the registered trademarks of Harmonic Drive Systems Inc.  
 Note. The movement range can be limited by changing the positions of X and Y axis mechanical stoppers. (The movement range is set to the maximum at the time of shipment.)  
 See our robot manuals (installation manuals) for detailed information.  
 Note. To set the standard coordinates with high accuracy, use a standard coordinate setting jig (option). Refer to the user's manual (installation manual) for more details.

Our robot manuals (installation manuals) can be downloaded from our website at the address below:  
<http://global.yamaha-motor.com/business/robot/>

## YK600XG

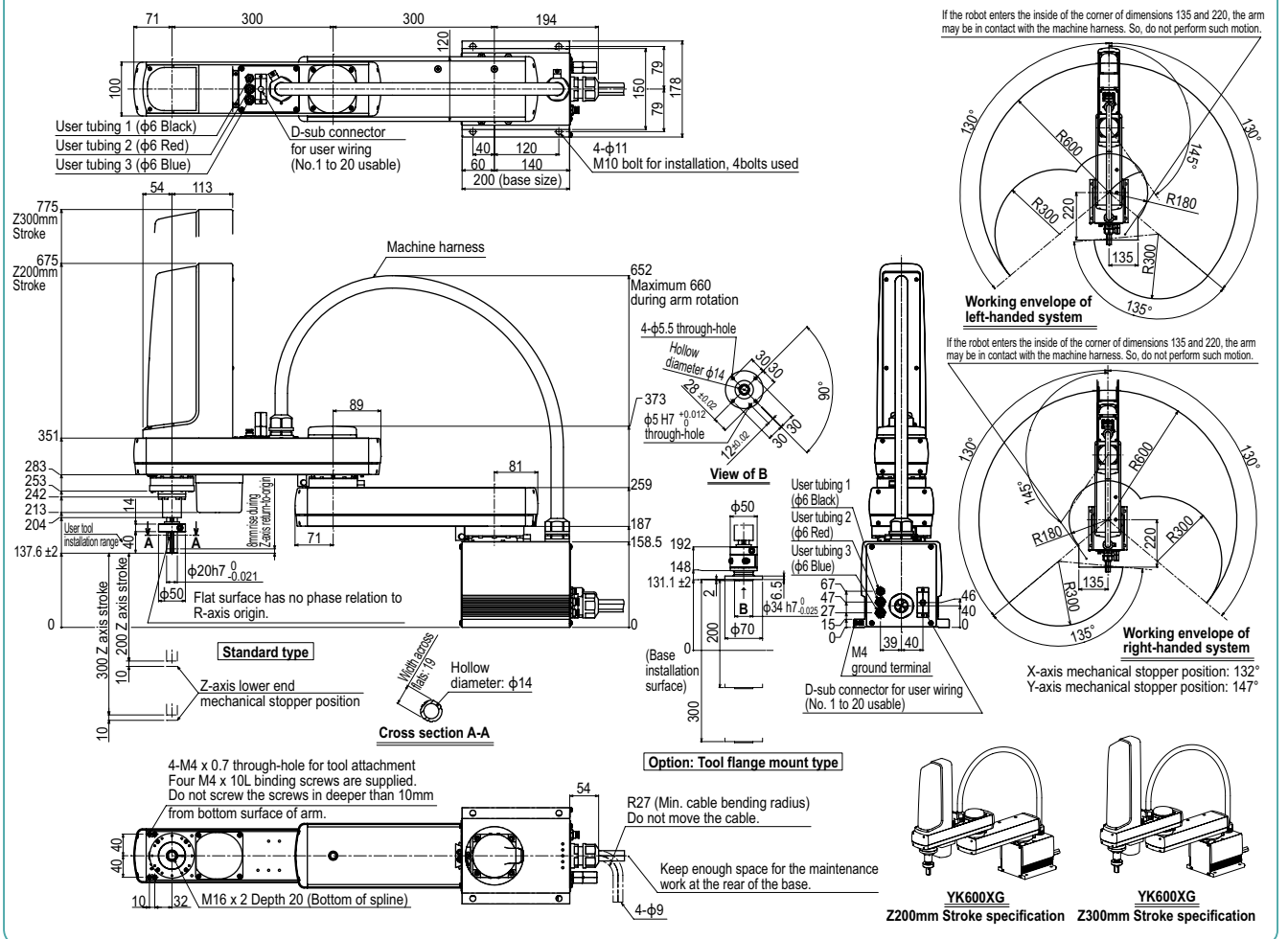

# YK600XGH

Standard type: Medium type

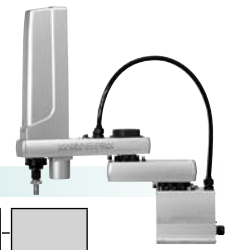

- Arm length 600mm
- Maximum payload 20kg

## Ordering method

**YK600XGH** [ ] [ ] [ ] **RCX340-4** [ ] [ ] [ ] [ ] [ ] [ ] [ ] [ ] [ ]

Model      Z axis stroke  
200: 200mm  
400: 400mm

Tool flange  
No entry: None  
F: With tool flange

Cable  
3L: 3.5m  
5L: 5m  
10L: 10m

Controller / Number of controllable axes      Safety standard      Option A (OP.A)      Option B (OP.B)      Option C (OP.C)      Option D (OP.D)      Option E (OP.E)      Absolute battery

**RCX240** [ ] [ ] [ ] [ ] [ ] [ ] [ ] [ ] [ ] **R3** [ ] [ ] [ ] [ ] [ ] [ ] [ ] [ ] **BB**

Controller      CE Marking      Regenerative unit      Expansion I/O      Network option      IVY System      Gripper      Battery

Specify various controller setting items. RCX340 ▶ **P.508**

Specify various controller setting items. RCX240/RCX240S ▶ **P.495**

## Specifications

		X-axis	Y-axis	Z-axis	R-axis
Axis specifications	Arm length	200 mm	400 mm	200 mm 400 mm	—
	Rotation angle	+/-130 °	+/-150 °	—	+/-360 °
AC servo motor output		750 W	400 W	400 W	200 W
Deceleration mechanism	Speed reducer	Harmonic drive	Harmonic drive	Ball screw	Harmonic drive
	Transmission method	Direct-coupled			
	Motor to speed reducer Speed reducer to output	Direct-coupled			
Repeatability <sup>Note 1</sup>		+/-0.02 mm	+/-0.01 mm	+/-0.01 mm	+/-0.004 °
Maximum speed		7.7 m/sec	2.3 m/sec 1.7 m/sec		920 °/sec
Maximum payload		20 kg			
Standard cycle time: with 2kg payload <sup>Note 2</sup>		0.47 sec			
R-axis tolerable moment of inertia <sup>Note 3</sup>		1.0 kg <sup>2</sup>			
User wiring		0.2 sq × 20 wires			
User tubing (Outer diameter)		φ 6 × 3			
Travel limit		1.Soft limit 2.Mechanical stopper (X,Y,Z axis)			
Robot cable length		Standard: 3.5 m Option: 5 m, 10 m			
Weight		Z axis 200 mm: 48 kg Z axis 400 mm: 50 kg			

Note 1. This is the value at a constant ambient temperature. (X,Y axes)  
 Note 2. When reciprocating 300mm in horizontal and 25mm in vertical directions.  
 Note 3. There are limits to acceleration coefficient settings. See P.539.  
 Note. Please consult YAMAHA when connecting other tubes and cables to the self-supporting machine harness.

## Controller

Controller	Power capacity (VA)	Operation method
RCX340 RCX240-R3	2500	Programming / I/O point trace / Remote command / Operation using RS-232C communication

Note. "Harmonic" and "Harmonic drive" are the registered trademarks of Harmonic Drive Systems Inc.  
 Note. The movement range can be limited by changing the positions of X and Y axis mechanical stoppers. (The movement range is set to the maximum at the time of shipment.)  
 See our robot manuals (installation manuals) for detailed information.  
 Note. To set the standard coordinates with high accuracy, use a standard coordinate setting jig (option). Refer to the user's manual (installation manual) for more details.

Our robot manuals (installation manuals) can be downloaded from our website at the address below:  
<http://global.yamaha-motor.com/business/robot/>

## YK600XGH

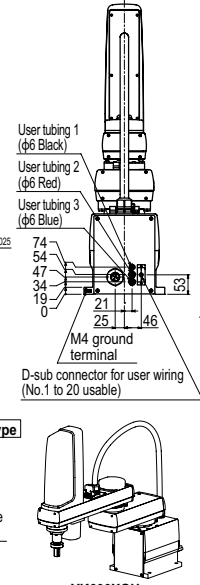
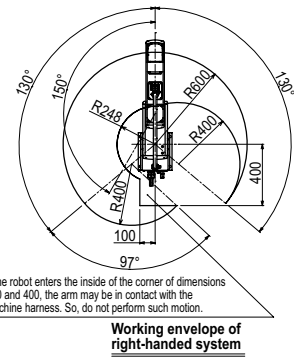
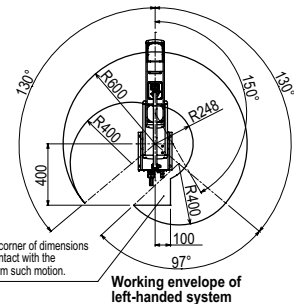
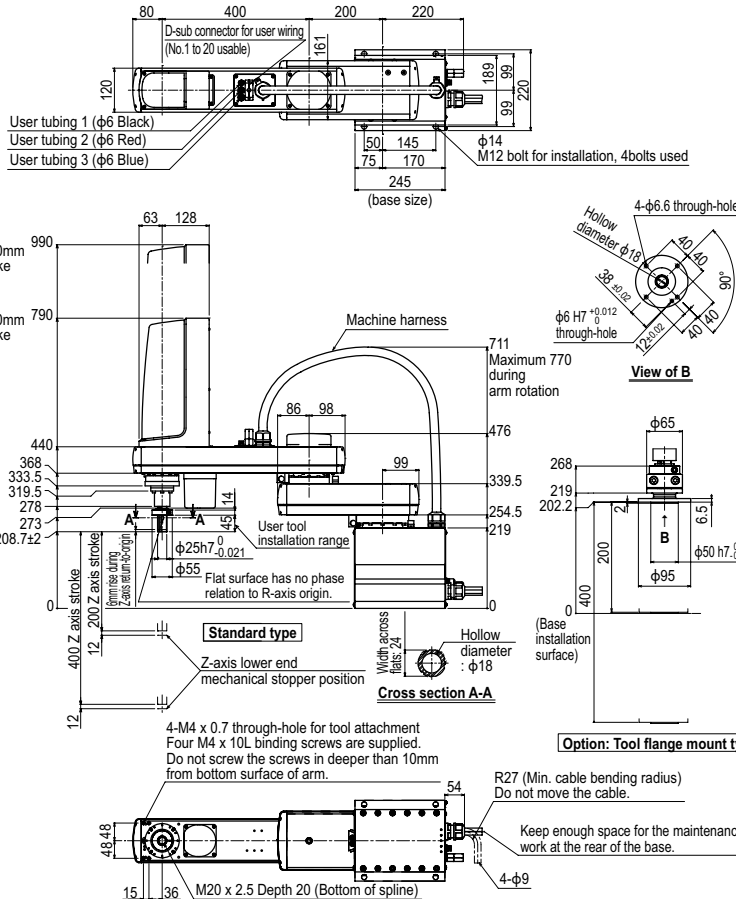

YK600XGH Z200mm Stroke specification      YK600XGH Z400mm Stroke specification

# YK700XGL

Standard type: Large type

- Arm length 700mm
- Maximum payload 10kg

Note. This model is a special order product. Please consult us for delivery time.

## Ordering method

**YK700XGL**       **RCX340-4**                    

Model	Z axis stroke	Tool flange	Cable	Controller / Number of controllable axes	Safety standard	Option A (OP.A)	Option B (OP.B)	Option C (OP.C)	Option D (OP.D)	Option E (OP.E)	Absolute battery
	Z: 200mm 300: 300mm	No entry: None F: With tool flange	3L: 3.5m 5L: 5m 10L: 10m								

Specify various controller setting items. RCX340 ▶ **P.508**

## Specifications

	X-axis	Y-axis	Z-axis	R-axis
<b>Axis specifications</b>				
Arm length	400 mm	300 mm	200 mm / 300 mm	-
Rotation angle	+/-130 °	+/-145 °	-	+/-360 °
<b>AC servo motor output</b>	400 W	200 W	200 W	200 W
<b>Deceleration mechanism</b>	Speed reducer	Harmonic drive	Harmonic drive	Ball screw
	Transmission method	Direct-coupled		
	Motor to speed reducer	Direct-coupled		
	Speed reducer to output	Direct-coupled		
<b>Repeatability</b> <sup>Note 1</sup>	+/-0.01 mm		+/-0.01 mm	+/-0.005 °
<b>Maximum speed</b>	9.2 m/sec		2.3 m/sec / 1.7 m/sec	1700 °/sec
<b>Maximum payload</b>	10 kg (Standard type), 9 kg (Option: Tool flange mount type)			
<b>Standard cycle time: with 2kg payload</b> <sup>Note 2</sup>	0.50 sec			
<b>R-axis tolerable moment of inertia</b> <sup>Note 3</sup>	0.30 kgm <sup>2</sup>			
<b>User wiring</b>	0.2 sq x 20 wires			
<b>User tubing (Outer diameter)</b>	φ6 x 3			
<b>Travel limit</b>	1. Soft limit 2. Mechanical stopper (X,Y,Z axis)			
<b>Robot cable length</b>	Standard: 3.5 m Option: 5, 10 m			
<b>Weight</b>	32 kg			

Note 1. This is the value at a constant ambient temperature. (X,Y axes)  
 Note 2. When reciprocating 300mm in horizontal and 25mm in vertical directions.  
 Note 3. There are limits to acceleration coefficient settings.

## Controller

Controller	Power capacity (VA)	Operation method
RCX340	1700	Programming / I/O point trace / Remote command / Operation using RS-232C communication

Note. "Harmonic" and "Harmonic drive" are the registered trademarks of Harmonic Drive Systems Inc.  
 Note. The movement range can be limited by changing the positions of X and Y axis mechanical stoppers. (The movement range is set to the maximum at the time of shipment.)  
 See our robot manuals (installation manuals) for detailed information.  
 Note. To set the standard coordinates with high accuracy, use a standard coordinate setting jig (option). Refer to the user's manual (installation manual) for more details.

Our robot manuals (installation manuals) can be downloaded from our website at the address below:  
<http://global.yamaha-motor.com/business/robot/>

## YK700XGL

**D-sub connector for user wiring (No.1 to 20 usable)**

71 300 400 194 150 79 178 79 150

User tubing 1 (φ6 Black)  
 User tubing 2 (φ6 Red)  
 User tubing 3 (φ6 Blue)

40 120 60 140 200 (base size) 4-φ11 M10 bolt for installation, 4bolts used

775 300mm Stroke  
 675 220mm Stroke

Machine harness

652 Maximum 710 during arm rotation  
 4-φ5.5 through-hole

Hollow diameter: φ14  
 28<sup>+0.02</sup>  
 φ5 H7<sup>+0.012</sup>  
 through-hole

**View of B**

**Option: Tool flange mount type**

φ50  
 192  
 158.5 148  
 131.1+/-2  
 0  
 200  
 300  
 (Base installation surface)

Width across flats: 19  
 Hollow diameter: φ14

**Cross section A-A**

4-M4 x 0.7 through-hole for tool attachment  
 Four M4 x 10L binding screws are supplied.  
 Do not screw the screws in deeper than 10mm from bottom surface of arm.

Keep enough space for the maintenance work at the rear of the base.

40 40 10 32 M16 x 2 Depth 20 (Bottom of spline)  
 R27 (Min. cable bending radius)  
 Do not move the cable.

4-φ9

**Working envelope of right-handed system**

130° 145° 130°  
 R700 R231 R300

**Working envelope of left-handed system**

130° 145° 130°  
 R700 R231 R300

X-axis mechanical stopper position: 132°  
 Y-axis mechanical stopper position: 147°

User tubing 1 (φ6 Black)  
 User tubing 2 (φ6 Red)  
 User tubing 3 (φ6 Blue)

67 47 27 15 0 39 40 46 40 0  
 M4 ground terminal

D-sub connector for user wiring (No. 1 to 20 usable)

**YK700XGL**  
 Z200mm Stroke specification

**YK700XGL**  
 Z300mm Stroke specification

APPLICATION  
 Linear conveyor / modules  
 LCM100

Compact single-axis robots  
 TRANSERVO

Single-axis robots  
 FLIP-X

Linear motor single-axis robots  
 PHASER

Cartesian robots  
 XX-X

SCARA robots  
 YK-X

Pick & place robots  
 YP-X

CLEAN

CONTROLLER INFORMATION

Orbit / Tiry type

Small / Medium types

Large type

Walk-mount / Inverse type

Dust-proof & drip-proof type

# YK700XG

Standard type: Large type

● Arm length 700mm ● Maximum payload 20kg

## Ordering method

**YK700XG**    **RCX340-4**

Model	Z axis stroke	Tool flange	Cable	Controller / Number of controllable axes	Safety standard	Option A (OP.A)	Option B (OP.B)	Option C (OP.C)	Option D (OP.D)	Option E (OP.E)	Absolute battery
	200: 200mm 400: 400mm	No entry: None F: With tool flange	3L: 3.5m 5L: 5m 10L: 10m								

Specify various controller setting items. RCX340 ▶ **P.508**

**RCX240**  **R3**      **BB**

Controller	CE Marking	Regenerative unit	Expansion I/O	Network option	IVY System	Gripper	Battery

Specify various controller setting items. RCX240/RCX240S ▶ **P.495**

## Specifications

		X-axis	Y-axis	Z-axis	R-axis
Axis specifications	Arm length	300 mm	400 mm	200 mm 400 mm	—
	Rotation angle	+/-130 °	+/-150 °	—	+/-360 °
AC servo motor output		750 W	400 W	400 W	200 W
Deceleration mechanism	Speed reducer	Harmonic drive	Harmonic drive	Ball screw	Harmonic drive
	Transmission method	Direct-coupled			
Motor to speed reducer		Direct-coupled			
Speed reducer to output		Direct-coupled			
Repeatability <sup>Note 1</sup>		+/-0.02 mm	+/-0.01 mm	+/-0.01 mm	+/-0.004 °
Maximum speed		8.4 m/sec	2.3 m/sec	1.7 m/sec	920 °/sec
Maximum payload		20 kg			
Standard cycle time: with 2kg payload <sup>Note 2</sup>		0.42 sec			
R-axis tolerable moment of inertia <sup>Note 3</sup>		1.0 kgm <sup>2</sup>			
User wiring		0.2 sq × 20 wires			
User tubing (Outer diameter)		φ 6 × 3			
Travel limit		1.Soft limit 2.Mechanical stopper (X,Y,Z axis)			
Robot cable length		Standard: 3.5 m Option: 5 m, 10 m			
Weight		Z axis 200 mm: 50 kg Z axis 400 mm: 52 kg			

Note 1. This is the value at a constant ambient temperature. (X,Y axes)  
 Note 2. When reciprocating 300mm in horizontal and 25mm in vertical directions.  
 Note 3. There are limits to acceleration coefficient settings. See P.539.  
 Note. Please consult YAMAHA when connecting other tubes and cables to the self-supporting machine harness.

## Controller

Controller	Power capacity (VA)	Operation method
RCX340 RCX240-R3	2500	Programming / I/O point trace / Remote command / Operation using RS-232C communication

Note. "Harmonic" and "Harmonic drive" are the registered trademarks of Harmonic Drive Systems Inc.  
 Note. The movement range can be limited by changing the positions of X and Y axis mechanical stoppers. (The movement range is set to the maximum at the time of shipment.)  
 See our robot manuals (installation manuals) for detailed information.  
 Note. To set the standard coordinates with high accuracy, use a standard coordinate setting jig (option). Refer to the user's manual (installation manual) for more details.

Our robot manuals (installation manuals) can be downloaded from our website at the address below:  
<http://global.yamaha-motor.com/business/robot/>

## YK700XG

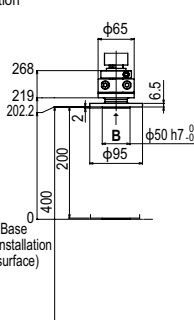
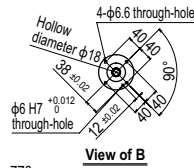
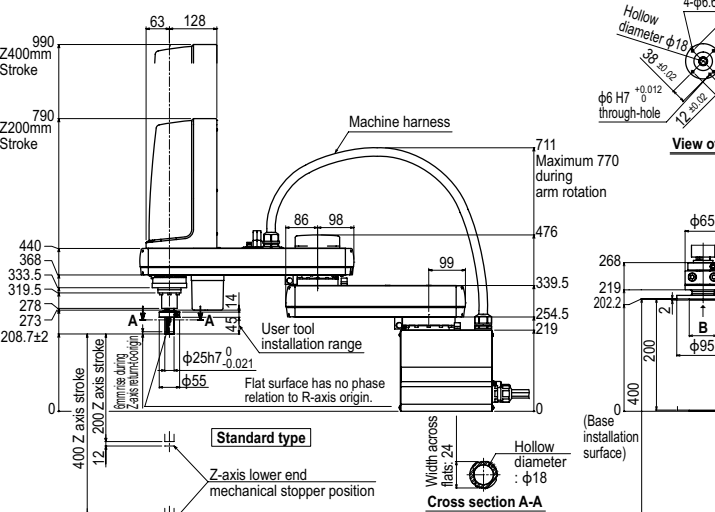
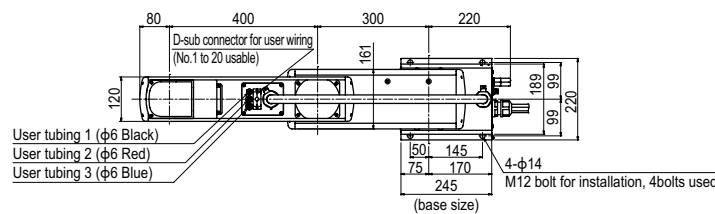

If the robot enters the inside of R30 and corner of dimensions 100 and 300, the Z-axis upper end stopper or tool flange may be in contact with the base or the arm may be in contact with the machine harness. So, do not perform such motion.

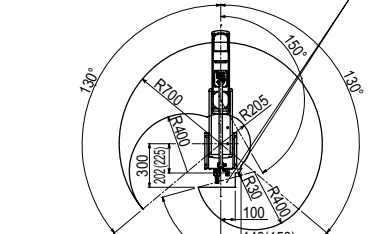

If the robot enters the inside of R30 and corner of dimensions 100 and 300, the Z-axis upper end stopper or tool flange may be in contact with the base or the arm may be in contact with the machine harness. So, do not perform such motion.

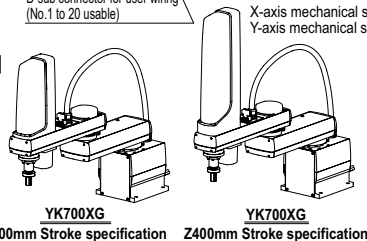
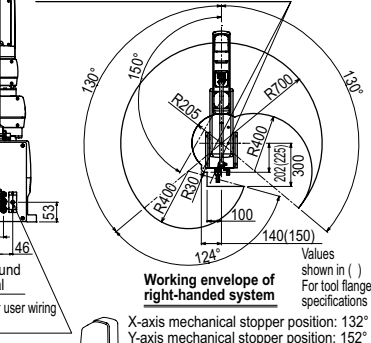

# YK800XG

Standard type: Large type

- Arm length 800mm
- Maximum payload 20kg

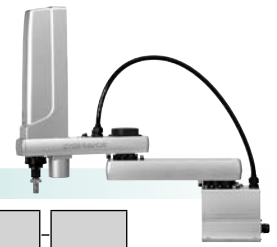

## Ordering method

### YK800XG

Model	Z axis stroke	Tool flange	Cable
	200: 200mm 400: 400mm	No entry: None F: With tool flange	3L: 3.5m 5L: 5m 10L: 10m

### RCX340-4

Controller / Number of controllable axes	Safety standard	Option A (OP.A)	Option B (OP.B)	Option C (OP.C)	Option D (OP.D)	Option E (OP.E)	Absolute battery
--	-----------------	-----------------	-----------------	-----------------	-----------------	-----------------	------------------

Specify various controller setting items. RCX340 ▶ **P.508**

### RCX240

Controller	CE Marking	Regenerative unit	Expansion I/O	Network option	IVY System	Gripper	Battery
------------	------------	-------------------	---------------	----------------	------------	---------	---------

Specify various controller setting items. RCX240/RCX240S ▶ **P.495**

## Specifications

		X-axis	Y-axis	Z-axis	R-axis
Axis specifications	Arm length	400 mm	400 mm	200 mm	400 mm
	Rotation angle	+/-130 °	+/-150 °	-	+/-360 °
AC servo motor output		750 W	400 W	400 W	200 W
Deceleration mechanism	Speed reducer	Harmonic drive	Harmonic drive	Ball screw	Harmonic drive
	Transmission method	Direct-coupled			
	Motor to speed reducer Speed reducer to output	Direct-coupled			
Repeatability <sup>Note 1</sup>		+/-0.02 mm		+/-0.01 mm	+/-0.004 °
Maximum speed		9.2 m/sec		2.3 m/sec	1.7 m/sec
Maximum payload		20 kg			
Standard cycle time: with 2kg payload <sup>Note 2</sup>		0.48 sec			
R-axis tolerable moment of inertia <sup>Note 3</sup>		1.0 kgm <sup>2</sup>			
User wiring		0.2 sq x 20 wires			
User tubing (Outer diameter)		φ 6 x 3			
Travel limit		1.Soft limit 2.Mechanical stopper (X,Y,Z axis)			
Robot cable length		Standard: 3.5 m Option: 5 m, 10 m			
Weight		Z axis 200 mm: 52 kg Z axis 400 mm: 54 kg			

Note 1. This is the value at a constant ambient temperature. (X,Y axes)  
 Note 2. When reciprocating 300mm in horizontal and 25mm in vertical directions.  
 Note 3. There are limits to acceleration coefficient settings. See P.539.  
 Note. Please consult YAMAHA when connecting other tubes and cables to the self-supporting machine harness.

## Controller

Controller	Power capacity (VA)	Operation method
RCX340 RCX240-R3	2500	Programming / I/O point trace / Remote command / Operation using RS-232C communication

Note. "Harmonic" and "Harmonic drive" are the registered trademarks of Harmonic Drive Systems, Inc.  
 Note. The movement range can be limited by changing the positions of X and Y axis mechanical stoppers. (The movement range is set to the maximum at the time of shipment.)  
 See our robot manuals (installation manuals) for detailed information.  
 Note. To set the standard coordinates with high accuracy, use a standard coordinate setting jig (option). Refer to the user's manual (installation manual) for more details.

Our robot manuals (installation manuals) can be downloaded from our website at the address below:  
<http://global.yamaha-motor.com/business/robot/>

## YK800XG

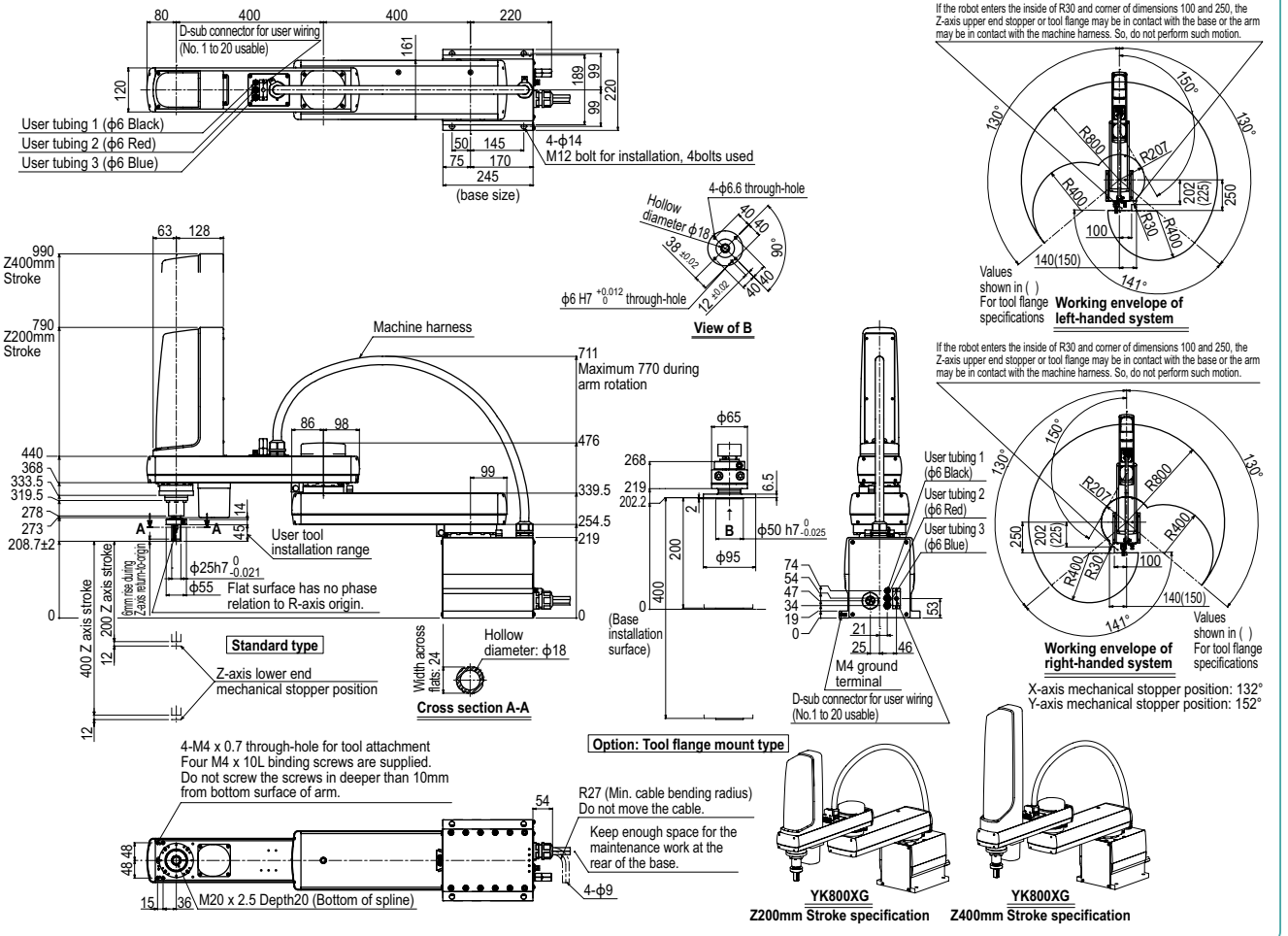

- APPLICATION
- Linear conveyor/ modules
- LCM100
- Compact single-axis robots
- TRANSERVO
- Single-axis robots
- FLIP-X
- Linear motor single-axis robots
- PHASER
- Cartesian robots
- XX-X
- SCARA robots
- YK-X
- Pick & place robots
- YP-X
- CLEAN
- CONTROLLER INFORMATION
- Orbit / T/Try type
- Small / Medium types
- Large type
- Walk-mount / Inverse type
- Dust-proof & drip-proof type

# YK900XG

Standard type: Large type

● Arm length 900mm ● Maximum payload 20kg



### Ordering method

**YK900XG**       **RCX340-4**              

<b>Model</b>	<b>Z axis stroke</b>	<b>Tool flange</b>	<b>Cable</b>	<b>Controller / Number of controllable axes</b>	<b>Safety standard</b>	<b>Option A (OP.A)</b>	<b>Option B (OP.B)</b>	<b>Option C (OP.C)</b>	<b>Option D (OP.D)</b>	<b>Option E (OP.E)</b>	<b>Absolute battery</b>
	200: 200mm 400: 400mm	No entry: None F: With tool flange	3L: 3.5m 5L: 5m 10L: 10m								

**Specify various controller setting items. RCX340 ▶ P.508**

**RCX240**   **R3**         **BB**

**Specify various controller setting items. RCX240/RCX240S ▶ P.495**

### Specifications

		X-axis	Y-axis	Z-axis	R-axis
<b>Axis specifications</b>	<b>Arm length</b>	500 mm	400 mm	200 mm 400 mm	-
	<b>Rotation angle</b>	+/-130 °	+/-150 °	-	+/-360 °
<b>AC servo motor output</b>		750 W	400 W	400 W	200 W
<b>Deceleration mechanism</b>	<b>Speed reducer</b>	Harmonic drive	Harmonic drive	Ball screw	Harmonic drive
	<b>Transmission method</b>	Direct-coupled			
	<b>Motor to speed reducer</b> <b>Speed reducer to output</b>	Direct-coupled			
<b>Repeatability</b> <sup>Note 1</sup>		+/-0.02 mm		+/-0.01 mm	+/-0.004 °
<b>Maximum speed</b>		9.9 m/sec		2.3 m/sec 1.7 m/sec	920 °/sec
<b>Maximum payload</b>				20 kg	
<b>Standard cycle time: with 2kg payload</b> <sup>Note 2</sup>			0.49 sec		
<b>R-axis tolerable moment of inertia</b> <sup>Note 3</sup>				1.0 kg <sup>2</sup>	
<b>User wiring</b>			0.2 sq × 20 wires		
<b>User tubing (Outer diameter)</b>		φ 6 × 3			
<b>Travel limit</b>		1.Soft limit 2.Mechanical stopper (X,Y,Z axis)			
<b>Robot cable length</b>		Standard: 3.5 m Option: 5 m, 10 m			
<b>Weight</b>		Z axis 200 mm: 54 kg Z axis 400 mm: 56 kg			

Note 1. This is the value at a constant ambient temperature. (X,Y axes)  
 Note 2. When reciprocating 300mm in horizontal and 25mm in vertical directions.  
 Note 3. There are limits to acceleration coefficient settings. See P.539.  
 Note. Please consult YAMAHA when connecting other tubes and cables to the self-supporting machine harness.

### Controller

Controller	Power capacity (VA)	Operation method
RCX340 RCX240-R3	2500	Programming / I/O point trace / Remote command / Operation using RS-232C communication

Note. "Harmonic" and "Harmonic drive" are the registered trademarks of Harmonic Drive Systems Inc.  
 Note. The movement range can be limited by changing the positions of X and Y axis mechanical stoppers. (The movement range is set to the maximum at the time of shipment.)  
 See our robot manuals (installation manuals) for detailed information.  
 Note. To set the standard coordinates with high accuracy, use a standard coordinate setting jig (option). Refer to the user's manual (installation manual) for more details.

Our robot manuals (installation manuals) can be downloaded from our website at the address below:  
<http://global.yamaha-motor.com/business/robot/>

### YK900XG

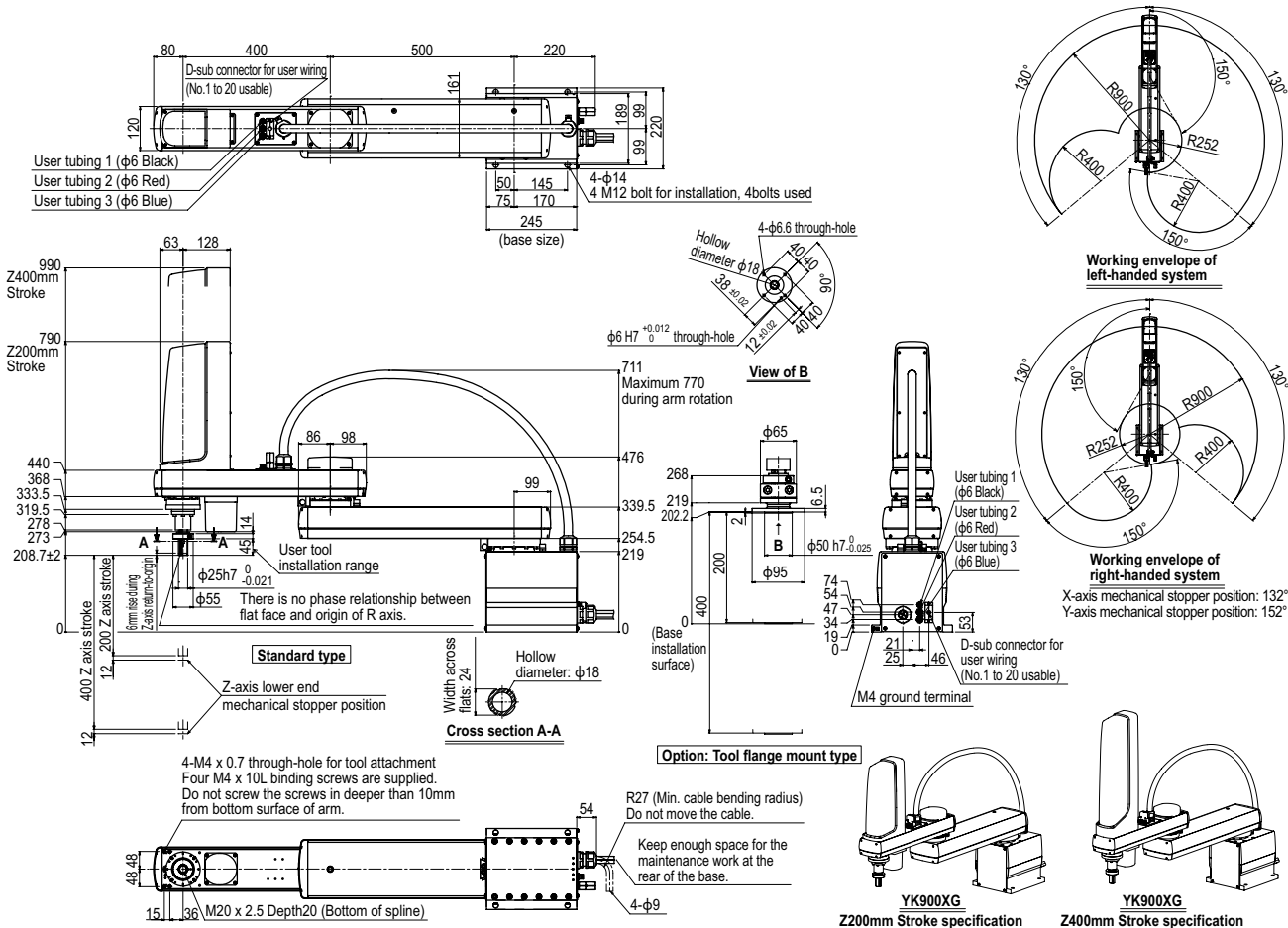

# YK1000XG

Standard type: Large type

- Arm length 1000mm
- Maximum payload 20kg

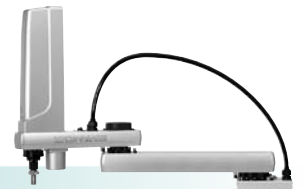

## Ordering method

**YK1000XG**

Model	Z axis stroke	Tool flange	Cable
	200: 200mm 400: 400mm	No entry: None F: With tool flange	3L: 3.5m 5L: 5m 10L: 10m

**RCX340-4**

Controller / Number of controllable axes	Safety standard	Option A (OP.A)	Option B (OP.B)	Option C (OP.C)	Option D (OP.D)	Option E (OP.E)	Absolute battery
--	-----------------	-----------------	-----------------	-----------------	-----------------	-----------------	------------------

Specify various controller setting items. RCX340 ▶ **P.508**

**RCX240**

Controller	CE Marking	Regenerative unit	Expansion I/O	Network option	IVY System	Gripper	Battery
------------	------------	-------------------	---------------	----------------	------------	---------	---------

Specify various controller setting items. RCX240/RCX240S ▶ **P.495**

## Specifications

		X-axis	Y-axis	Z-axis	R-axis
Axis specifications	Arm length	600 mm	400 mm	200 mm	400 mm
	Rotation angle	+/-130 °	+/-150 °	—	+/-360 °
AC servo motor output		750 W	400 W	400 W	200 W
Deceleration mechanism	Speed reducer	Harmonic drive	Harmonic drive	Ball screw	Harmonic drive
	Transmission method	Direct-coupled			
	Motor to speed reducer Speed reducer to output	Direct-coupled			
Repeatability <sup>Note 1</sup>		+/-0.02 mm		+/-0.01 mm	+/-0.004 °
Maximum speed		10.6 m/sec		2.3 m/sec	1.7 m/sec
Maximum payload		20 kg			
Standard cycle time: with 2kg payload <sup>Note 2</sup>		0.49 sec			
R-axis tolerable moment of inertia <sup>Note 3</sup>		1.0 kgm <sup>2</sup>			
User wiring		0.2 sq x 20 wires			
User tubing (Outer diameter)		φ 6 x 3			
Travel limit		1.Soft limit 2.Mechanical stopper (X,Y,Z axis)			
Robot cable length		Standard: 3.5 m Option: 5 m, 10 m			
Weight		Z axis 200 mm: 56 kg Z axis 400 mm: 58 kg			

Note 1. This is the value at a constant ambient temperature. (X,Y axes)  
 Note 2. When reciprocating 300mm in horizontal and 25mm in vertical directions.  
 Note 3. There are limits to acceleration coefficient settings. See P.539.  
 Note. Please consult YAMAHA when connecting other tubes and cables to the self-supporting machine harness.

## Controller

Controller	Power capacity (VA)	Operation method
RCX340 RCX240-R3	2500	Programming / I/O point trace / Remote command / Operation using RS-232C communication

Note. "Harmonic" and "Harmonic drive" are the registered trademarks of Harmonic Drive Systems, Inc.  
 Note. The movement range can be limited by changing the positions of X and Y axis mechanical stoppers. (The movement range is set to the maximum at the time of shipment.)  
 See our robot manuals (installation manuals) for detailed information.  
 Note. To set the standard coordinates with high accuracy, use a standard coordinate setting jig (option). Refer to the user's manual (installation manual) for more details.

Our robot manuals (installation manuals) can be downloaded from our website at the address below:  
<http://global.yamaha-motor.com/business/robot/>

## YK1000XG

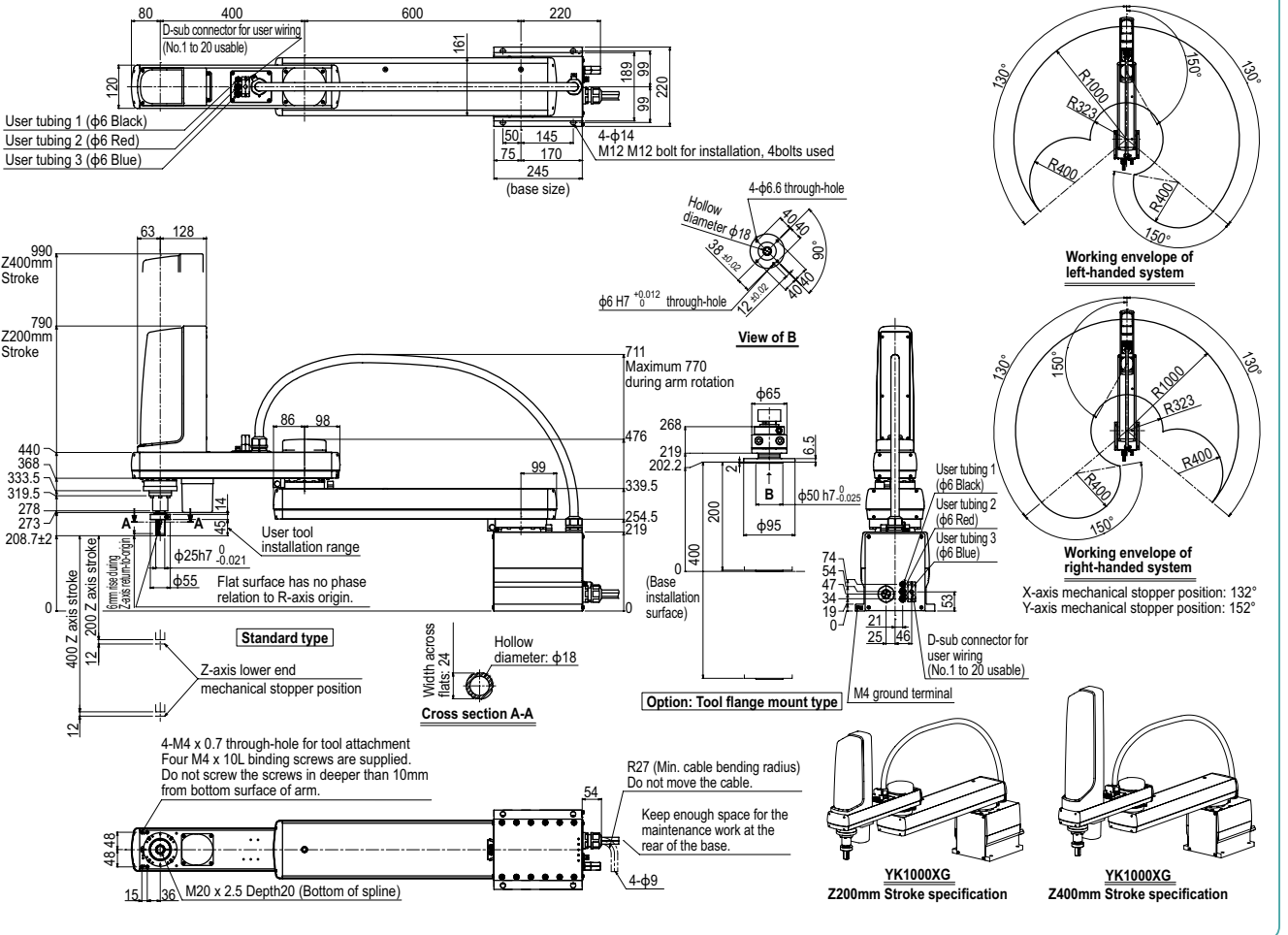



# YK1200X

Standard type: Large type



- Arm length 1200mm
- Maximum payload 50kg

## Ordering method

**YK1200X - 400**

Model	Z axis stroke	Cable
		3L: 3.5m
		5L: 5m
		10L: 10m

**RCX340-4**

Controller / Number of controllable axes	Safety standard	Option A (OP.A)	Option B (OP.B)	Option C (OP.C)	Option D (OP.D)	Option E (OP.E)	Absolute battery
--	-----------------	-----------------	-----------------	-----------------	-----------------	-----------------	------------------

Specify various controller setting items. RCX340 ▶ **P.508**

**RCX240**

Controller	CE Marking	Regenerative unit	Expansion I/O	Network option	IVY System	Gripper	Battery
------------	------------	-------------------	---------------	----------------	------------	---------	---------

Specify various controller setting items. RCX240/RCX240S ▶ **P.495**

## Specifications

		X-axis	Y-axis	Z-axis	R-axis
Axis specifications	Arm length	600 mm	600 mm	400 mm	-
	Rotation angle	+/-125 °	+/-150 °	-	+/-360 °
AC servo motor output		900 W	800 W	600 W	400 W
Deceleration mechanism	Speed reducer	Planetary gear	Planetary gear	Ball screw	Harmonic drive
	Transmission method	Motor to speed reducer	Direct-coupled	Timing belt transmission	Timing belt transmission
		Speed reducer to output	Direct-coupled	Direct-coupled	Direct-coupled
Repeatability <sup>Note 1</sup>		+/-0.05 mm	+/-0.02 mm	+/-0.005 °	
Maximum speed		7.4 m/sec	0.75 m/sec	600 °/sec	
Maximum payload		50 kg			
Standard cycle time: with 2kg payload <sup>Note 2</sup>		0.91 sec			
R-axis tolerable moment of inertia <sup>Note 3</sup>		2.45 kgm <sup>2</sup>			
User wiring		0.2 sq × 20 wires			
User tubing (Outer diameter)		φ 6 × 3			
Travel limit		1.Soft limit 2.Mechanical stopper (X,Y,Z axis)			
Robot cable length		Standard: 3.5 m Option: 5 m, 10 m			
Weight		124 kg			

Note 1. This is the value at a constant ambient temperature. (X,Y axes)  
 Note 2. When reciprocating 300mm in horizontal and 25mm in vertical directions.  
 Note 3. There are limits to acceleration coefficient settings. See P.540.

## Controller

Controller	Power capacity (VA)	Operation method
RCX340 RCX240-R	2500	Programming / I/O point trace / Remote command / Operation using RS-232C communication

Note. "Harmonic" and "Harmonic drive" are the registered trademarks of Harmonic Drive Systems Inc.  
 Note. The movement range can be limited by changing the positions of X and Y axis mechanical stoppers. (The movement range is set to the maximum at the time of shipment.)  
 See our robot manuals (installation manuals) for detailed information.

Our robot manuals (installation manuals) can be downloaded from our website at the address below:  
<http://global.yamaha-motor.com/business/robot/>

## YK1200X

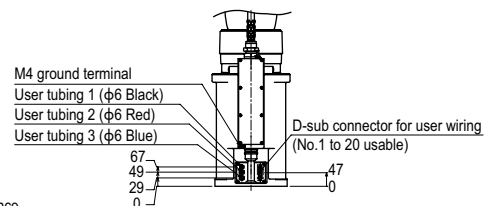
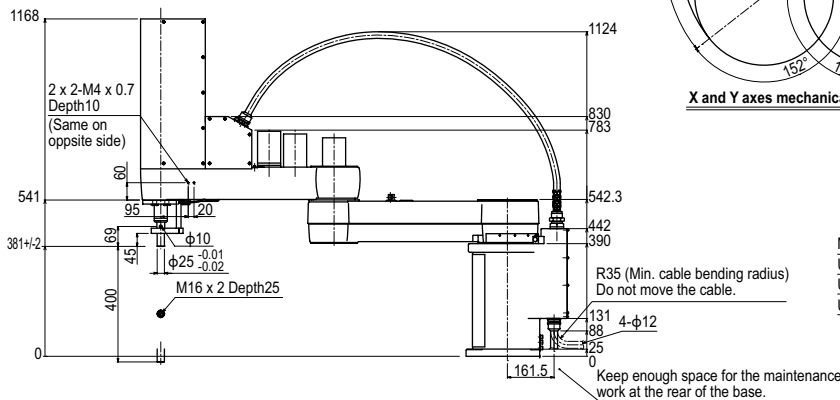
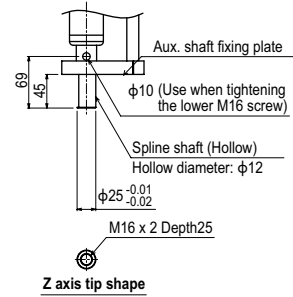
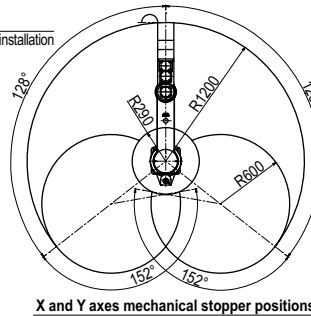
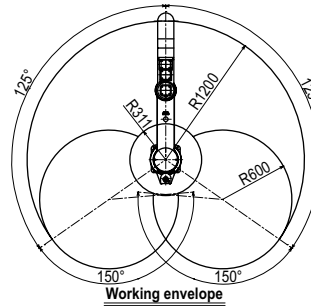
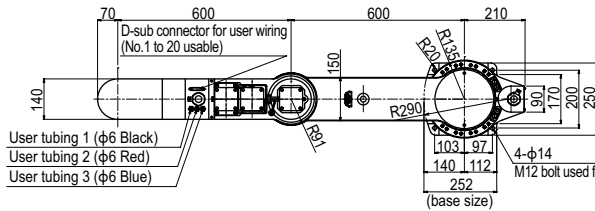

# YK300XGS

Wall-mount / inverse type

● Arm length 300mm ● Maximum payload 5kg

Note. Built-to-order product.  
Contact us for the delivery period.

## Ordering method

**YK300XGS** **150** **RCX340-4** **BB**

**Model** - **Installation method** <sup>Note1</sup> - **Z axis stroke** - **Tool flange** - **Hollow shaft** - **Cable**

W: Wall-mount (same as per external view)  
U: Inverse wall-mount (upside down)

No entry: None  
F: With tool flange

No entry: None  
S: With hollow shaft

3L: 3.5m  
5L: 5m  
10L: 10m

**Controller / Number of controllable axes** - **Safety standard** - **Option A (OP.A)** - **Option B (OP.B)** - **Option C (OP.C)** - **Option D (OP.D)** - **Option E (OP.E)** - **Absolute battery**

**Specify various controller setting items. RCX340 ▶ P.508**

**RCX240S** **BB**

**Controller** - **CE Marking** - **Expansion I/O** - **Network option** - **IVY System** - **Gripper** - **Battery**

**Specify various controller setting items. RCX240/RCX240S ▶ P.495**

Note 1. When installing the robot, always follow the specifications.  
Do not install the ceiling-mount robot upside down or do not install the inverse type robot to a ceiling.  
Incorrect installation can cause trouble or malfunction.

## Specifications

		X-axis	Y-axis	Z-axis	R-axis
<b>Axis specifications</b>	<b>Arm length</b>	150 mm	150 mm	150 mm	-
	<b>Rotation angle</b>	+/-120 °	+/-130 °	-	+/-360 °
<b>AC servo motor output</b>		200 W	150 W	50 W	100 W
<b>Deceleration mechanism</b>	<b>Speed reducer</b>	Harmonic drive	Harmonic drive	Ball screw	Harmonic drive
	<b>Transmission method</b>	Direct-coupled			
	<b>Motor to speed reducer</b>	Direct-coupled			
	<b>Speed reducer to output</b>	Direct-coupled			
<b>Repeatability</b> <sup>Note 1</sup>		+/-0.01 mm	+/-0.01 mm	+/-0.01 mm	+/-0.004 °
<b>Maximum speed</b>		4.4 m/sec	1.0 m/sec	1020 °/sec (wall-mount) 720 °/sec (inverse wall-mount)	
<b>Maximum payload</b>		5 kg (Standard specification), 4 kg (Option specifications <sup>Note 4</sup> )			
<b>Standard cycle time: with 2kg payload</b> <sup>Note 2</sup>		0.49 sec			
<b>R-axis tolerable moment of inertia</b> <sup>Note 3</sup>		0.05 kgm <sup>2</sup>			
<b>User wiring</b>		0.2 sq x 10 wires			
<b>User tubing (Outer diameter)</b>		φ 4 x 3			
<b>Travel limit</b>		1.Soft limit 2.Mechanical stopper (X,Y,Z axis)			
<b>Robot cable length</b>		Standard: 3.5 m Option: 5 m, 10 m			
<b>Weight</b>		19.5 kg			

Note 1. This is the value at a constant ambient temperature.  
Note 2. When reciprocating 25mm horizontally and 300mm horizontally (with a 2kg payload in rough-positioning arch motion).  
Note 3. There are limits to acceleration coefficient settings. See P.537.  
Note 4. Maximum payload of option specifications (with tool flange attached or with user wiring and tubing routed through spline shaft) is 4kg.

## Controller

Controller	Power capacity (VA)	Operation method
RCX340 RCX240S	1000	Programming / I/O point trace / Remote command / Operation using RS-232C communication

Note. "Harmonic" and "Harmonic drive" are the registered trademarks of Harmonic Drive Systems Inc.  
Note. The movement range can be limited by changing the position of Y axis mechanical stopper. (The movement range is set to the maximum at the time of shipment.)  
See our robot manuals (installation manuals) for detailed information.

Our robot manuals (installation manuals) can be downloaded from our website at the address below:  
<http://global.yamaha-motor.com/business/robot/>

## YK300XGS

**D-sub connector for user wiring (No. 1 to 10 usable)**

**Working envelope**  
X-axis mechanical stopper position: 122°  
Y-axis mechanical stopper position: 132°

**(Option)**

- Additional Z-axis upper limit stopper: Allows changing the Z-axis origin position to a point 12mm, 15mm or 18mm (in 3mm steps) lower than the standard position.
- Additional Z-axis lower limit stopper: Allows changing the Z-axis stopper position to a point 17mm or more higher than the standard position. (Lower limit of working envelope: 4mm from additional stopper) (Cannot be used when user wiring and tubing are set through spline shaft.)

**Option: User wiring/tubing through spline type**  
Note. Inverse type is installed upside down.

APPLICATION  
Linear conveyor modules  
LCM100

TRANSERVO  
Compact single-axis robots

FLIP-X  
Single-axis robots

PHASER  
Linear motor single-axis robots

XY-X  
Cartesian robots

YK-X  
SCARA robots

YP-X  
Pick & place robots

CLEAN  
CLEAN

CONTROLLER INFORMATION  
Orbit / TriV type  
Small / Medium type  
Large type  
Wall-mount / Inverse type  
Dust-proof & drip-proof type

## YK300XGS Tool flange mount type

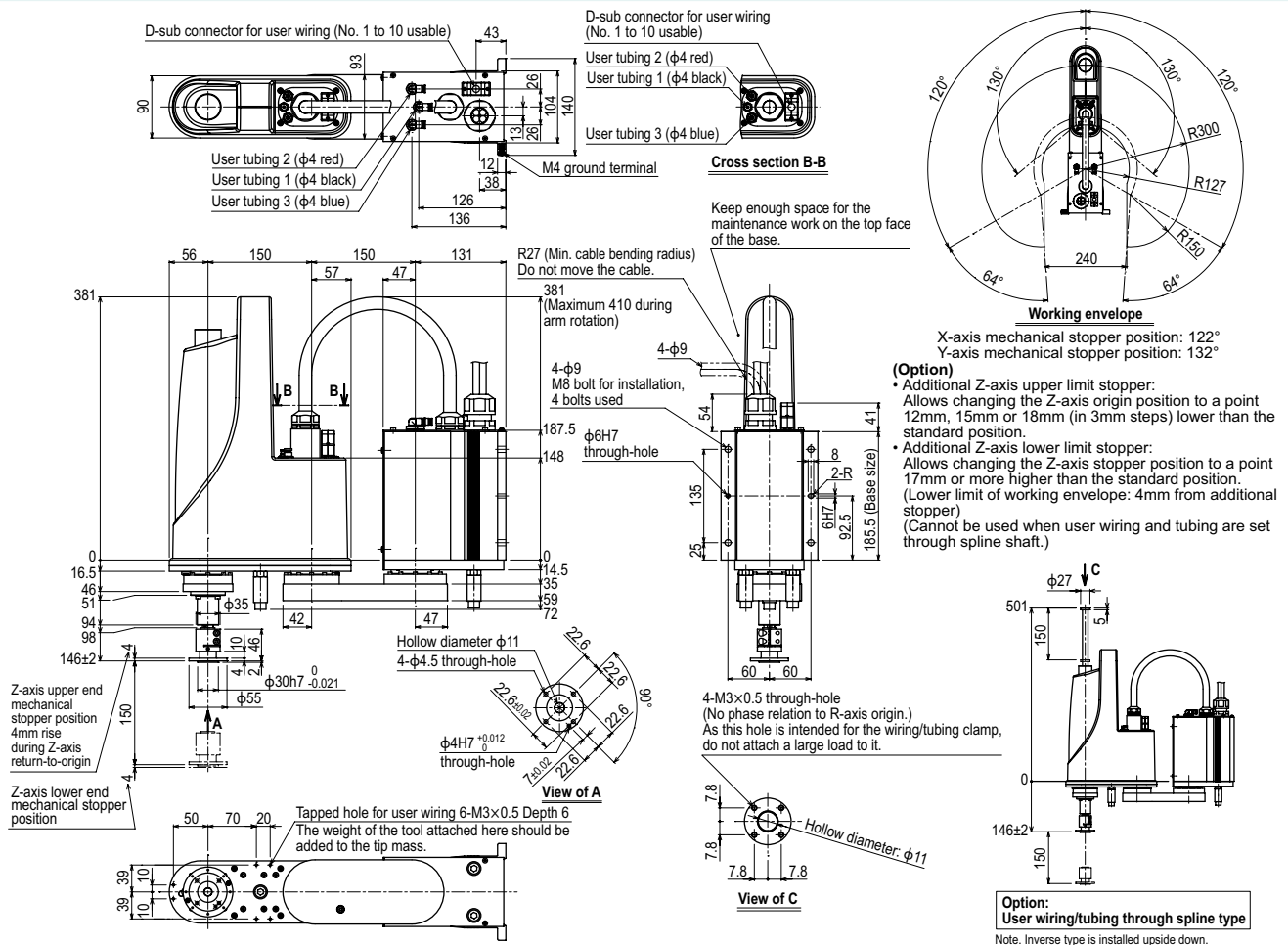

# YK400XGS

Wall-mount / inverse type

- Arm length 400mm
- Maximum payload 5kg

Note. Built-to-order product.  
Contact us for the delivery period.

## Ordering method

**YK400XGS** **150** **RCX340-4** **RCX240S**

**Model** **Installation method** **Z axis stroke** **Tool flange** **Hollow shaft** **Cable** **Controller / Number of controllable axes** **Safety standard** **Option A (OP.A)** **Option B (OP.B)** **Option C (OP.C)** **Option D (OP.D)** **Option E (OP.E)** **Absolute battery**

W: Wall-mount (same as per external view)  
U: Inverse wall-mount (upside down)

No entry: None  
F: With tool flange  
No entry: None  
S: With hollow shaft

3L: 3.5m  
5L: 5m  
10L: 10m

Specify various controller setting items. RCX340 ▶ **P.508**

Specify various controller setting items. RCX240/RCX240S ▶ **P.495**

**BB** **Controller** **CE Marking** **Expansion I/O** **Network option** **IVY System** **Gripper** **Battery**

Note 1. When installing the robot, always follow the specifications.  
Do not install the ceiling-mount robot upside down or do not install the inverse type robot to a ceiling.  
Incorrect installation can cause trouble or malfunction.

## Specifications

	X-axis	Y-axis	Z-axis	R-axis
<b>Axis specifications</b>	250 mm	150 mm	150 mm	-
<b>Rotation angle</b>	+/-125 °	+/-144 °	-	+/-360 °
<b>AC servo motor output</b>	200 W	150 W	50 W	100 W
<b>Deceleration mechanism</b>	Harmonic drive	Harmonic drive	Ball screw	Harmonic drive
<b>Speed reducer</b>	Direct-coupled			
<b>Transmission method</b>	Direct-coupled			
<b>Motor to speed reducer</b>	Direct-coupled			
<b>Speed reducer to output</b>	Direct-coupled			
<b>Repeatability</b>	+/-0.01 mm	+/-0.01 mm	+/-0.004 °	
<b>Maximum speed</b>	6.1 m/sec	1.1 m/sec	1020 °/sec (wall-mount) 720 °/sec (inverse wall-mount)	
<b>Maximum payload</b>	5 kg (Standard specification), 4 kg (Option specifications)			
<b>Standard cycle time: with 2kg payload</b>	0.49 sec			
<b>R-axis tolerable moment of inertia</b>	0.05 kgm <sup>2</sup>			
<b>User wiring</b>	0.2 sq x 10 wires			
<b>User tubing (Outer diameter)</b>	φ 4 x 3			
<b>Travel limit</b>	1.Soft limit 2.Mechanical stopper (X,Y,Z axis)			
<b>Robot cable length</b>	Standard: 3.5 m Option: 5 m, 10 m			
<b>Weight</b>	20 kg			

Note 1. This is the value at a constant ambient temperature.  
Note 2. When reciprocating 25mm horizontally and 300mm horizontally (with a 2kg payload in rough-positioning arch motion).  
Note 3. There are limits to acceleration coefficient settings. See P.538.  
Note 4. Maximum payload of option specifications (with tool flange attached or with user wiring and tubing routed through spline shaft) is 4kg.

## Controller

Controller	Power capacity (VA)	Operation method
RCX340 RCX240S	1000	Programming / I/O point trace / Remote command / Operation using RS-232C communication

Note. "Harmonic" and "Harmonic drive" are the registered trademarks of Harmonic Drive Systems Inc.  
Note. The movement range can be limited by changing the position of Y axis mechanical stopper. (The movement range is set to the maximum at the time of shipment.)  
See our robot manuals (installation manuals) for detailed information.

Our robot manuals (installation manuals) can be downloaded from our website at the address below:  
<http://global.yamaha-motor.com/business/robot/>

## YK400XGS

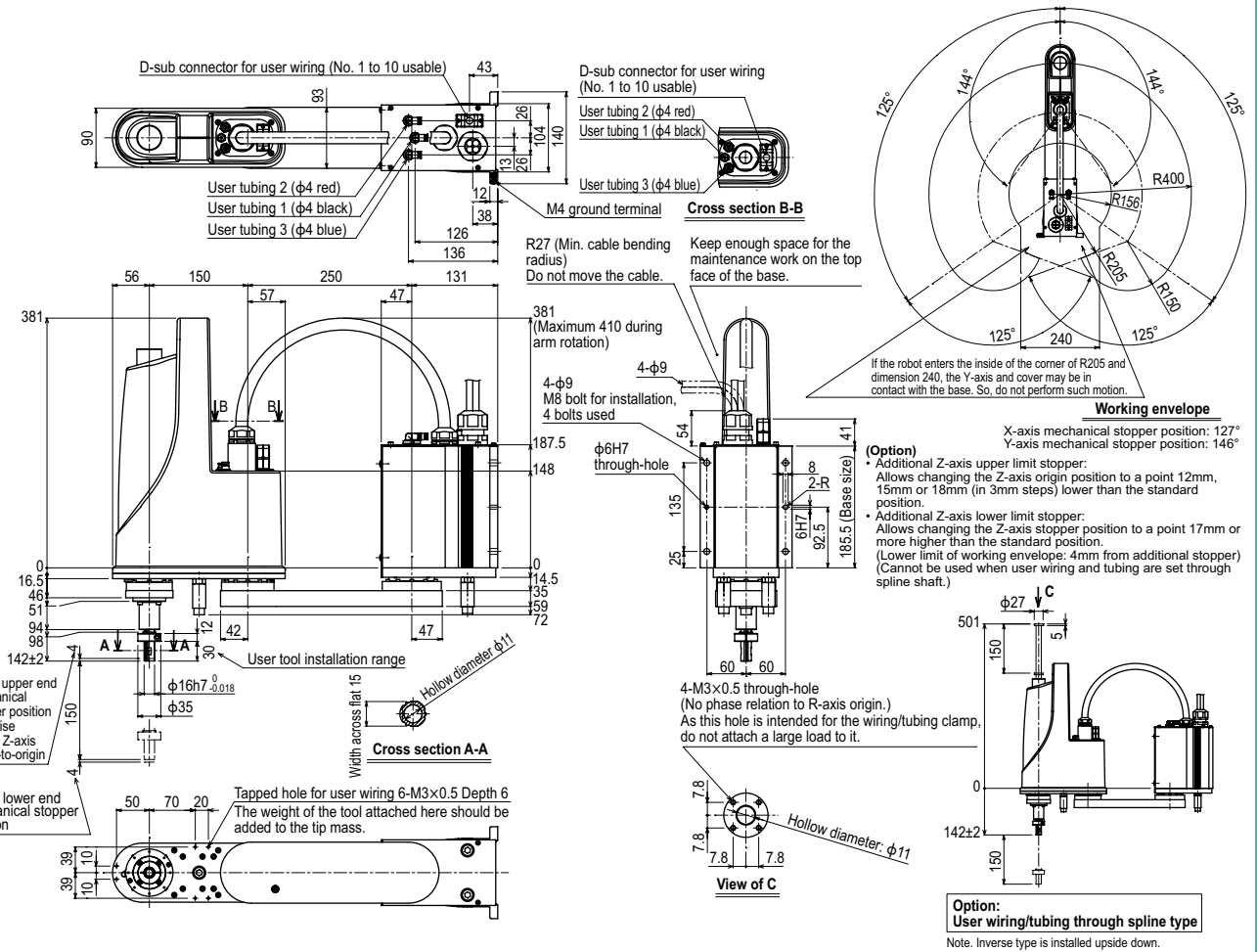

APPLICATION  
LCM100  
TRANSEURO  
FLIP-X  
PHASER  
XY-X  
YK-X  
YP-X  
CLEAN  
CONTROLLER INFORMATION  
Orbit / TriV type  
Small / Medium type  
Large type  
Wall-mount / Inverse type  
Dust-proof & drip-proof type

## YK400XGS Tool flange mount type

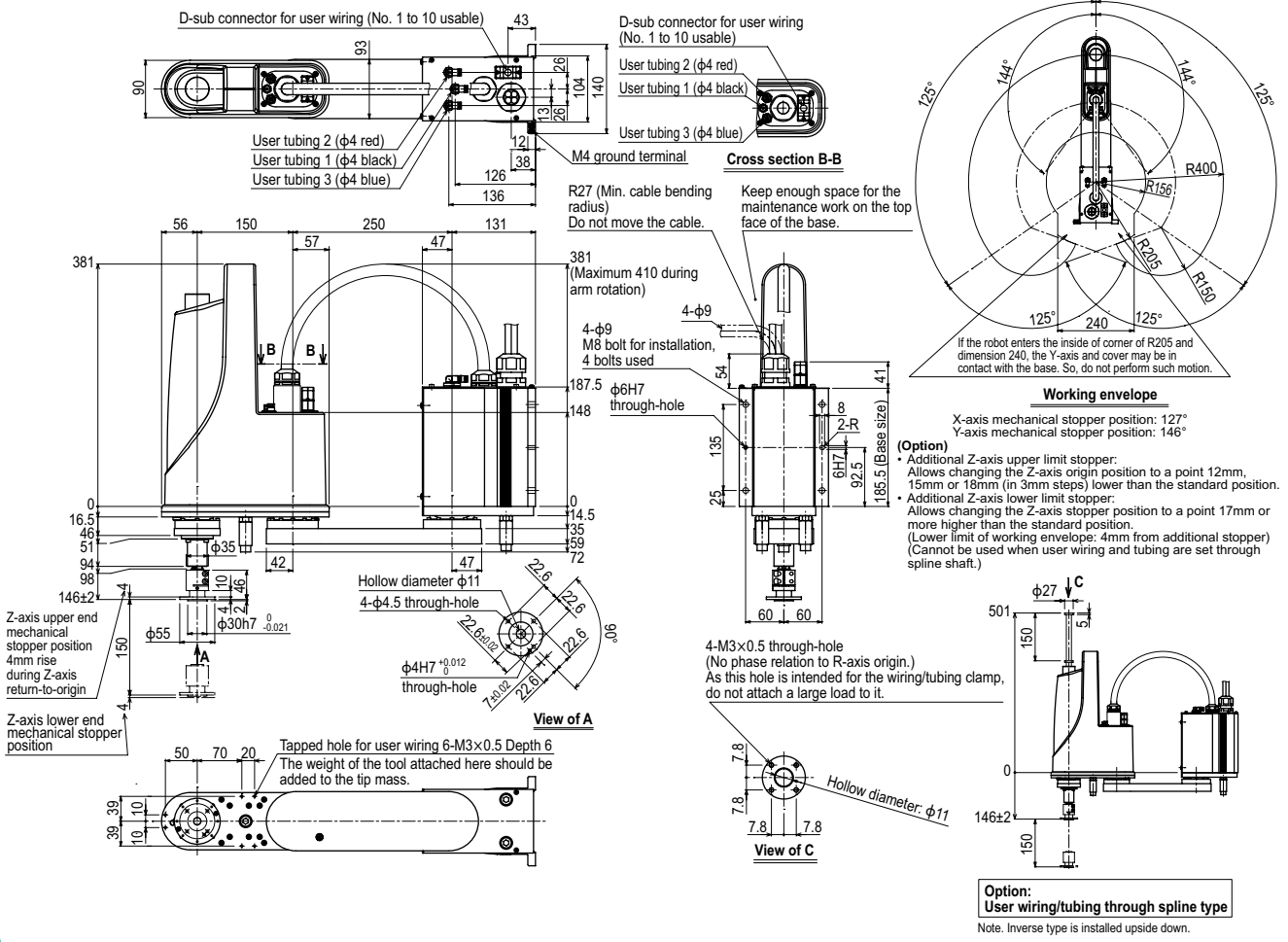

# YK500XGS

Wall-mount / inverse type

- Arm length 500mm
- Maximum payload 10kg

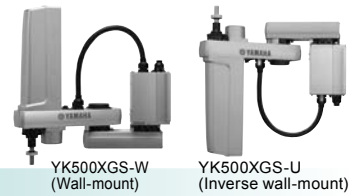

## Ordering method

### YK500XGS

Model	Installation method <sup>Note 1</sup>	Z axis stroke	Tool flange	Cable
	W: Wall-mount (same as per external view) U: Inverse wall-mount (upside down)	200: 200mm 300: 300mm	No entry: None F: With tool flange	3L: 3.5m 5L: 5m 10L: 10m

### RCX340-4

Controller / Number of controllable axes	Safety standard	Option A (OP.A)	Option B (OP.B)	Option C (OP.C)	Option D (OP.D)	Option E (OP.E)	Absolute battery
--	-----------------	-----------------	-----------------	-----------------	-----------------	-----------------	------------------

Specify various controller setting items. RCX340 ▶ **P.508**

### RCX240

Controller	CE Marking	Regenerative unit	Expansion I/O	Network option	IVY System	Gripper	Battery
------------	------------	-------------------	---------------	----------------	------------	---------	---------

Specify various controller setting items. RCX240/RCX240S ▶ **P.495**

Note 1. When installing the robot, always follow the specifications.  
Do not install the ceiling-mount robot upside down or do not install the inverse type robot to a ceiling.  
Incorrect installation can cause trouble or malfunction.

## Specifications

		X-axis	Y-axis	Z-axis	R-axis
Axis specifications	Arm length	200 mm	300 mm	200 mm/300 mm	-
	Rotation angle	+/-105 °	+/-125 °	-	+/-360 °
AC servo motor output		400 W	200 W	200 W	200 W
Deceleration mechanism	Speed reducer	Harmonic drive	Harmonic drive	Ball screw	Harmonic drive
	Transmission method	Direct-coupled			
		Speed reducer to output			
Repeatability <sup>Note 1</sup>		+/-0.01 mm	+/-0.01 mm	+/-0.004 °	
Maximum speed		7.6 m/sec	2.3 m/sec	1.7 m/sec	1700 °/sec (wall-mount) 800 °/sec (inverse wall-mount)
Maximum payload		10 kg (Standard specification), 9 kg (Option specifications)			
Standard cycle time: with 2kg payload <sup>Note 2</sup>		0.45 sec			
R-axis tolerable moment of inertia <sup>Note 3</sup>		0.30 kgm <sup>2</sup>			
User wiring		0.2 sq × 20 wires			
User tubing (Outer diameter)		φ 6 × 3			
Travel limit		1. Soft limit 2. Mechanical stopper (X,Y,Z axis)			
Robot cable length		Standard: 3.5 m Option: 5 m, 10 m			
Weight		30 kg			

Note 1. This is the value at a constant ambient temperature. (X,Y axes)  
Note 2. When reciprocating 300mm in horizontal and 25mm in vertical directions.  
Note 3. There are limits to acceleration coefficient settings. See P.539.  
Note. Please consult YAMAHA when connecting other tubes and cables to the self-supporting machine harness.

## Controller

Controller	Power capacity (VA)	Operation method
RCX340 RCX240-R3	1700	Programming / I/O point trace / Remote command / Operation using RS-232C communication

Note. "Harmonic" and "Harmonic drive" are the registered trademarks of Harmonic Drive Systems Inc.  
Note. The movement range can be limited by changing the positions of X and Y axis mechanical stoppers. (The movement range is set to the maximum at the time of shipment.)  
See our robot manuals (installation manuals) for detailed information.

Our robot manuals (installation manuals) can be downloaded from our website at the address below:  
<http://global.yamaha-motor.com/business/robot/>

## YK500XGS

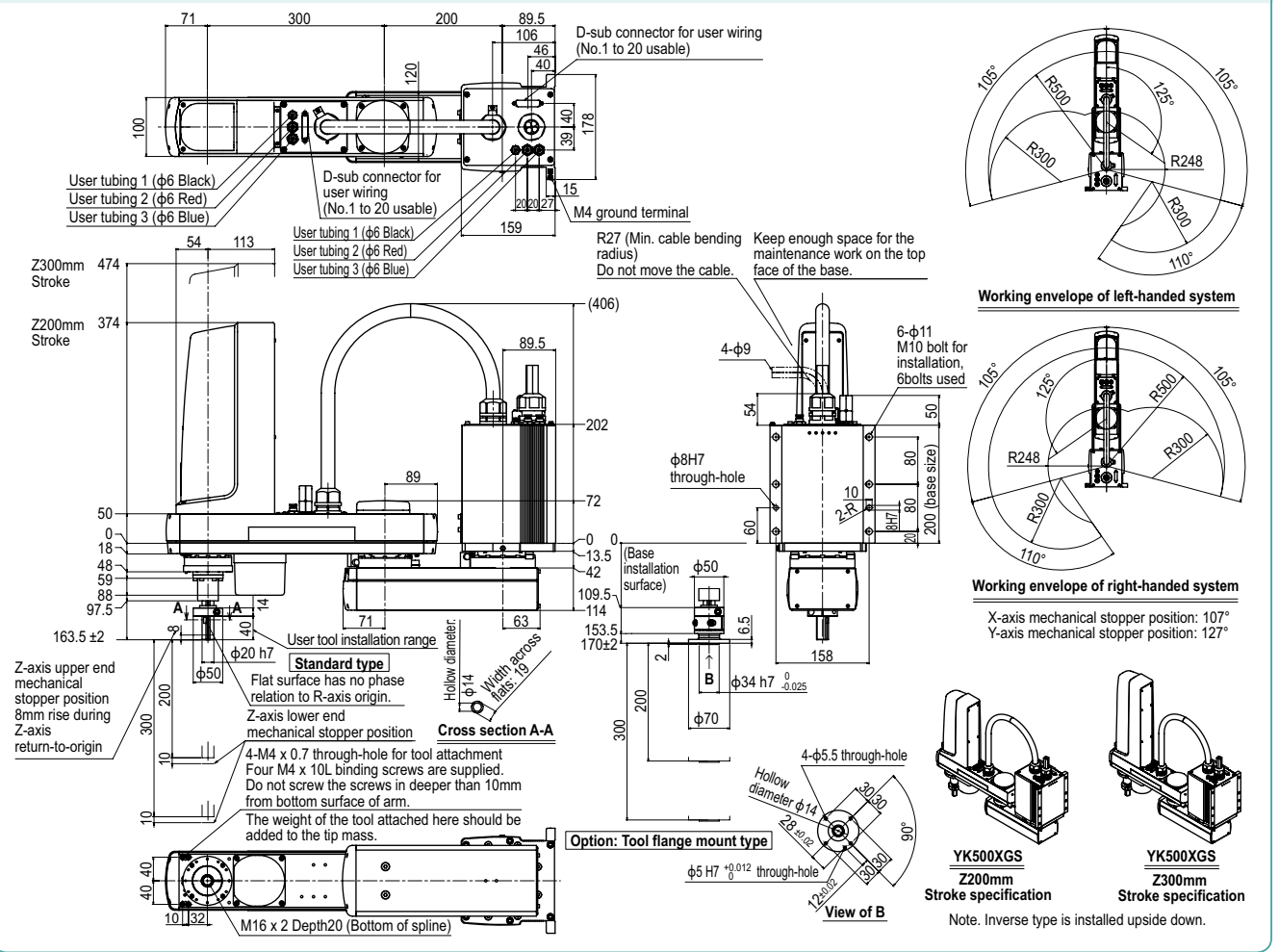

# YK600XGS

Wall-mount / inverse type

- Arm length 600mm
- Maximum payload 10kg



## Ordering method

### YK600XGS

Model	Installation method <sup>Note 1</sup>	Z axis stroke	Tool flange	Cable
	W: Wall-mount (same as per external view) U: Inverse wall-mount (upside down)	200: 200mm 300: 300mm	No entry: None F: With tool flange	3L: 3.5m 5L: 5m 10L: 10m

### RCX340-4

Controller / Number of controllable axes	Safety standard	Option A (OP.A)	Option B (OP.B)	Option C (OP.C)	Option D (OP.D)	Option E (OP.E)	Absolute battery
--	-----------------	-----------------	-----------------	-----------------	-----------------	-----------------	------------------

Specify various controller setting items. RCX340 ▶ P.508

### RCX240

Controller	CE Marking	Regenerative unit	Expansion I/O	Network option	IVY System	Gripper	Battery
------------	------------	-------------------	---------------	----------------	------------	---------	---------

Specify various controller setting items. RCX240/RCX240S ▶ P.495

Note 1. When installing the robot, always follow the specifications.  
Do not install the ceiling-mount robot upside down or do not install the inverse type robot to a ceiling.  
Incorrect installation can cause trouble or malfunction.

## Specifications

Axis specifications	Arm length	X-axis	Y-axis	Z-axis	R-axis
	300 mm	300 mm	200 mm	300 mm	-
	Rotation angle	+/-130°	+/-145°	-	+/-360°
AC servo motor output		400 W	200 W	200 W	200 W
Deceleration mechanism	Speed reducer	Harmonic drive	Harmonic drive	Ball screw	Harmonic drive
	Transmission method	Direct-coupled			
	Motor to speed reducer	Direct-coupled			
	Speed reducer to output	Direct-coupled			
Repeatability <sup>Note 1</sup>		+/-0.01 mm	+/-0.01 mm	+/-0.004°	
Maximum speed		8.4 m/sec	2.3 m/sec	1.7 m/sec	1700°/sec (wall-mount) 800°/sec (inverse wall-mount)
Maximum payload		10 kg (Standard specification), 9 kg (Option specifications)			
Standard cycle time: with 2kg payload <sup>Note 2</sup>		0.46 sec			
R-axis tolerable moment of inertia <sup>Note 3</sup>		0.30 kgm <sup>2</sup>			
User wiring		0.2 sq × 20 wires			
User tubing (Outer diameter)		φ 6 × 3			
Travel limit		1. Soft limit 2. Mechanical stopper (X,Y,Z axis)			
Robot cable length		Standard: 3.5 m Option: 5 m, 10 m			
Weight		31 kg			

Note 1. This is the value at a constant ambient temperature. (X,Y axes)  
Note 2. When reciprocating 300mm in horizontal and 25mm in vertical directions.  
Note 3. There are limits to acceleration coefficient settings. See P.539.  
Note. Please consult YAMAHA when connecting other tubes and cables to the self-supporting machine harness.

## Controller

Controller	Power capacity (VA)	Operation method
RCX340 RCX240-R3	1700	Programming / I/O point trace / Remote command / Operation using RS-232C communication

Note. "Harmonic" and "Harmonic drive" are the registered trademarks of Harmonic Drive Systems Inc.  
Note. The movement range can be limited by changing the positions of X and Y axis mechanical stoppers. (The movement range is set to the maximum at the time of shipment.)  
See our robot manuals (installation manuals) for detailed information.

Our robot manuals (installation manuals) can be downloaded from our website at the address below:  
<http://global.yamaha-motor.com/business/robot/>

## YK600XGS

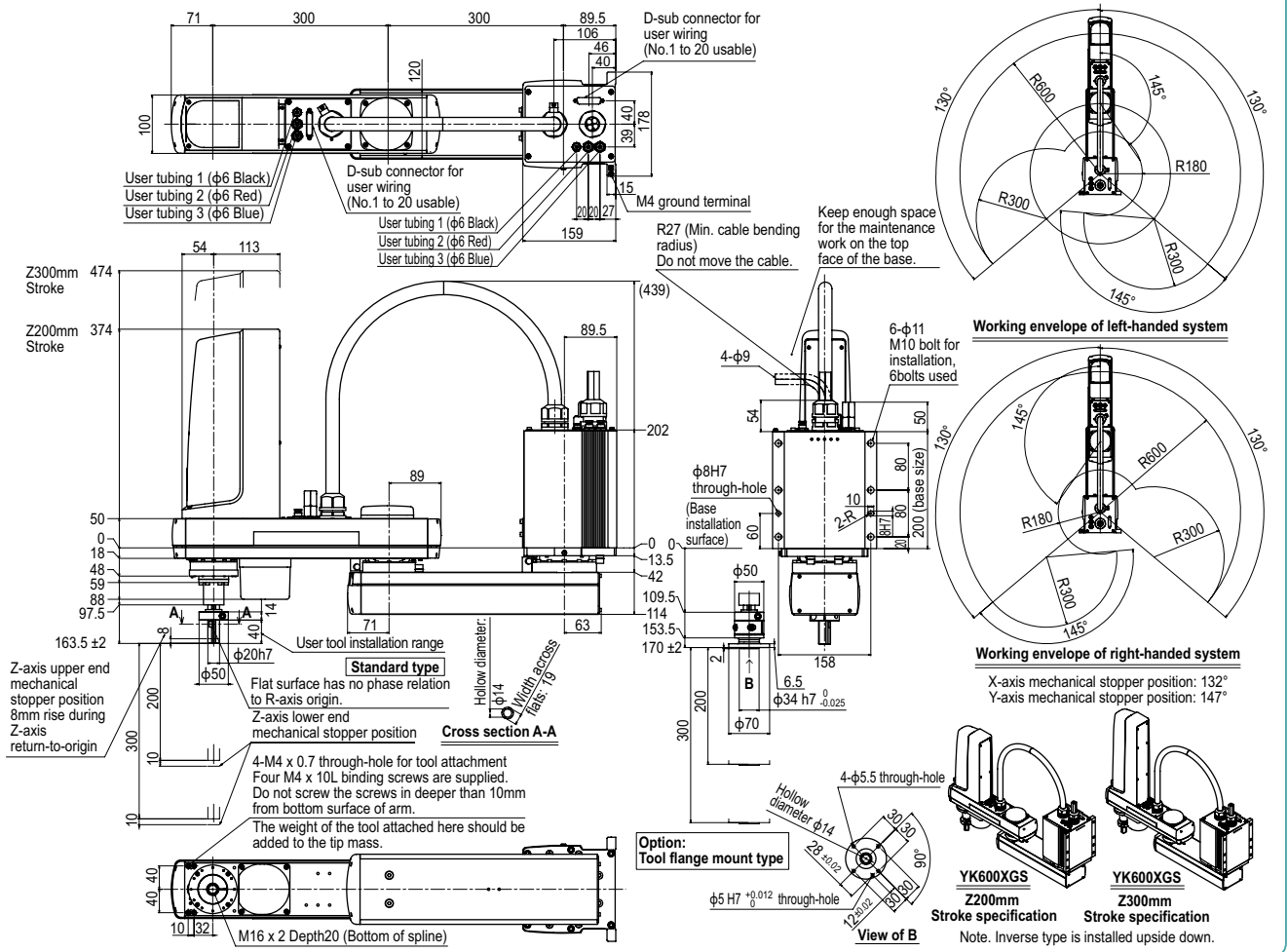

# YK700XGS

Wall-mount / inverse type

- Arm length 700mm
- Maximum payload 20kg

## Ordering method

### YK700XGS

Model	Installation method <sup>Note 1</sup>	Z axis stroke	Tool flange	Cable
	W: Wall-mount (same as per external view) I: Inverse wall-mount (upside down)	200: 200mm 400: 400mm	No entry: None F: With tool flange	3L: 3.5m 5L: 5m 10L: 10m

### RCX340-4

Controller / Number of controllable axes	Safety standard	Option A (OP.A)	Option B (OP.B)	Option C (OP.C)	Option D (OP.D)	Option E (OP.E)	Absolute battery
--	-----------------	-----------------	-----------------	-----------------	-----------------	-----------------	------------------

Specify various controller setting items. RCX340 ▶ P.508

### RCX240

Controller	CE Marking	Regenerative unit	Expansion I/O	Network option	IVY System	Gripper	Battery
------------	------------	-------------------	---------------	----------------	------------	---------	---------

Specify various controller setting items. RCX240/RCX240S ▶ P.495

Note 1. When installing the robot, always follow the specifications.  
Do not install the ceiling-mount robot upside down or do not install the inverse type robot to a ceiling.  
Incorrect installation can cause trouble or malfunction.

## Specifications

		X-axis	Y-axis	Z-axis	R-axis
Axis specifications	Arm length	300 mm	400 mm	200 mm/400 mm	—
	Rotation angle	+/-130 °	+/-130 °	—	+/-360 °
AC servo motor output		750 W	400 W	400 W	200 W
Deceleration mechanism	Speed reducer	Harmonic drive	Harmonic drive	Ball screw	Harmonic drive
	Transmission	Direct-coupled			
	Motor to speed reducer Speed reducer to output	Direct-coupled			
Repeatability <sup>Note 1</sup>		+/-0.02 mm	+/-0.01 mm	+/-0.004 °	
Maximum speed		8.4 m/sec	2.3 m/sec	1.7 m/sec	920 °/sec (wall-mount) 480 °/sec (inverse wall-mount)
Maximum payload		20 kg (Standard specification), 19 kg (Option specifications)			
Standard cycle time: with 2kg payload <sup>Note 2</sup>		0.42 sec			
R-axis tolerable moment of inertia <sup>Note 3</sup>		1.0 kgm <sup>2</sup>			
User wiring		0.2 sq × 20 wires			
User tubing (Outer diameter)		φ 6 × 3			
Travel limit		1. Soft limit 2. Mechanical stopper (X,Y,Z axis)			
Robot cable length		Standard: 3.5 m Option: 5 m, 10 m			
Weight		Z axis 200 mm: 50 kg Z axis 400 mm: 52 kg			

Note 1. This is the value at a constant ambient temperature. (X,Y axes)  
Note 2. When reciprocating 300mm in horizontal and 25mm in vertical directions.  
Note 3. There are limits to acceleration coefficient settings. See P.539.  
Note. Please consult YAMAHA when connecting other tubes and cables to the self-supporting machine harness.

## Controller

Controller	Power capacity (VA)	Operation method
RCX340 RCX240-R3	2500	Programming / I/O point trace / Remote command / Operation using RS-232C communication

Note. "Harmonic" and "Harmonic drive" are the registered trademarks of Harmonic Drive Systems Inc.  
Note. The movement range can be limited by changing the positions of X and Y axis mechanical stoppers. (The movement range is set to the maximum at the time of shipment.)  
See our robot manuals (installation manuals) for detailed information.

Our robot manuals (installation manuals) can be downloaded from our website at the address below:  
<http://global.yamaha-motor.com/business/robot/>

## YK700XGS

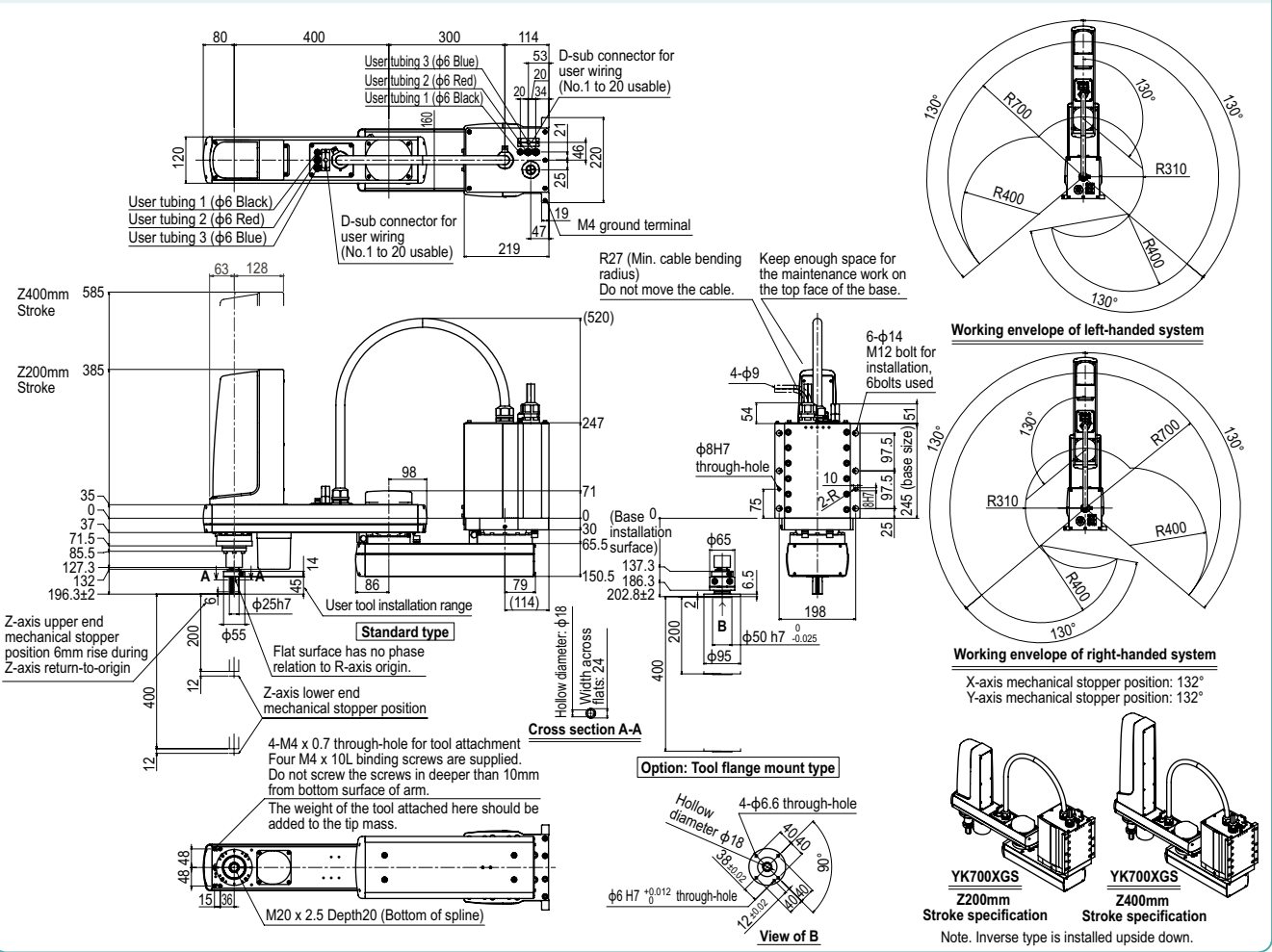



# YK800XGS

Wall-mount / inverse type

- Arm length 800mm
- Maximum payload 20kg

## Ordering method

### YK800XGS

Model	Installation method <sup>Note 1</sup>	Z axis stroke	Tool flange	Cable
	W: Wall-mount (same as per external view) U: Inverse wall-mount (upside down)	200: 200mm 400: 400mm	No entry: None F: With tool flange	3L: 3.5m 5L: 5m 10L: 10m

### RCX340-4

Controller / Number of controllable axes	Safety standard	Option A (OP.A)	Option B (OP.B)	Option C (OP.C)	Option D (OP.D)	Option E (OP.E)	Absolute battery
--	-----------------	-----------------	-----------------	-----------------	-----------------	-----------------	------------------

Specify various controller setting items. RCX340 ▶ P.508

### RCX240

Controller	CE Marking	Regenerative unit	Expansion I/O	Network option	IVY System	Gripper	Battery
------------	------------	-------------------	---------------	----------------	------------	---------	---------

Specify various controller setting items. RCX240/RCX240S ▶ P.495

Note 1. When installing the robot, always follow the specifications.  
Do not install the ceiling-mount robot upside down or do not install the inverse type robot to a ceiling.  
Incorrect installation can cause trouble or malfunction.

## Specifications

Axis specifications	Arm length	X-axis	Y-axis	Z-axis	R-axis
	Rotation angle	400 mm	400 mm	200 mm/400 mm	-
	AC servo motor output	+/-130 °	+/-145 °	-	+/-360 °
	Speed reducer	750 W	400 W	400 W	200 W
Deceleration mechanism	Transmission method	Harmonic drive	Harmonic drive	Ball screw	Harmonic drive
	Motor to speed reducer	Direct-coupled			
	Speed reducer to output	Direct-coupled			
Repeatability <sup>Note 1</sup>		+/-0.02 mm	+/-0.01 mm	+/-0.004 °	
Maximum speed		9.2 m/sec	2.3 m/sec	1.7 m/sec	920 °/sec (wall-mount) 480 °/sec (inverse wall-mount)
Maximum payload		20 kg (Standard specification), 19 kg (Option specifications)			
Standard cycle time: with 2kg payload <sup>Note 2</sup>		0.48 sec			
R-axis tolerable moment of inertia <sup>Note 3</sup>		1.0 kgm <sup>2</sup>			
User wiring		0.2 sq × 20 wires			
User tubing (Outer diameter)		φ 6 × 3			
Travel limit		1. Soft limit 2. Mechanical stopper (X,Y,Z axis)			
Robot cable length		Standard: 3.5 m Option: 5 m, 10 m			
Weight		Z axis 200 mm: 52 kg Z axis 400 mm: 54 kg			

Note 1. This is the value at a constant ambient temperature. (X,Y axes)  
Note 2. When reciprocating 300mm in horizontal and 25mm in vertical directions.  
Note 3. There are limits to acceleration coefficient settings. See P.539.  
Note. Please consult YAMAHA when connecting other tubes and cables to the self-supporting machine harness.

## Controller

Controller	Power capacity (VA)	Operation method
RCX340 RCX240-R3	2500	Programming / I/O point trace / Remote command / Operation using RS-232C communication

Note. "Harmonic" and "Harmonic drive" are the registered trademarks of Harmonic Drive Systems Inc.  
Note. The movement range can be limited by changing the positions of X and Y axis mechanical stoppers. (The movement range is set to the maximum at the time of shipment.)  
See our robot manuals (installation manuals) for detailed information.

Our robot manuals (installation manuals) can be downloaded from our website at the address below:  
<http://global.yamaha-motor.com/business/robot/>

## YK800XGS

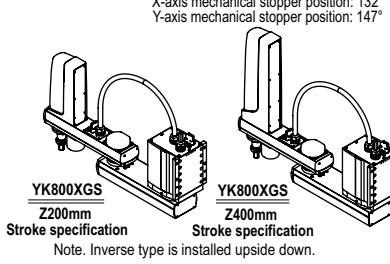
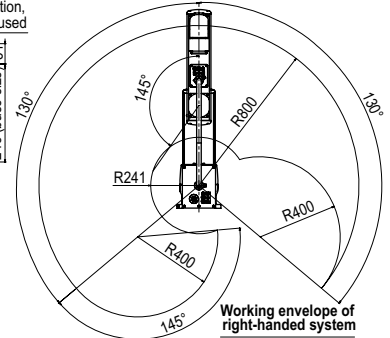
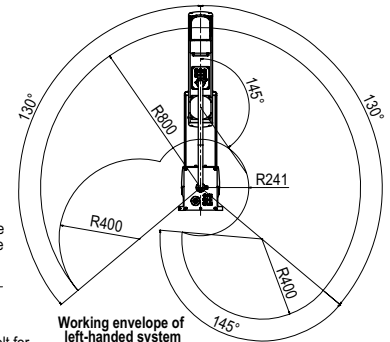
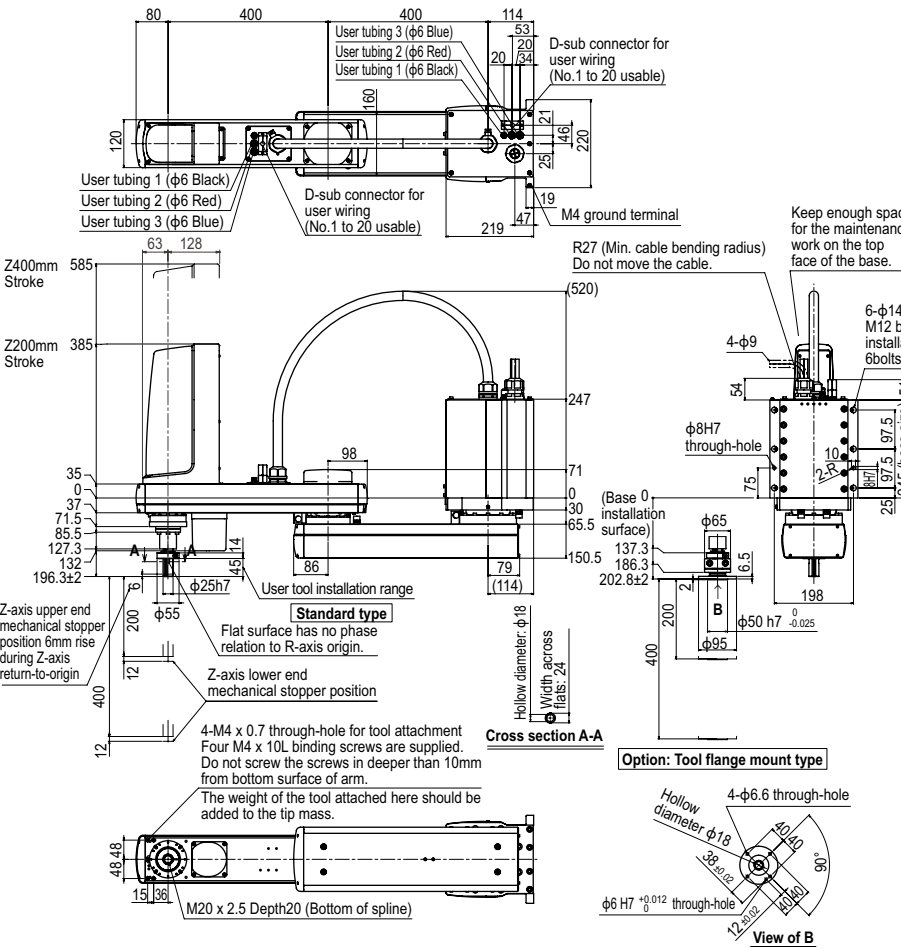

# YK900XGS

Wall-mount / inverse type

- Arm length 900mm
- Maximum payload 20kg

## Ordering method

**YK900XGS**

<b>Model</b>	<b>Installation method</b> W: Wall-mount (same as per external view) U: Inverse wall-mount (upside down)	<b>Z axis stroke</b> 200: 200mm 400: 400mm	<b>Tool flange</b> No entry: None F: With tool flange	<b>Cable</b> 3L: 3.5m 5L: 5m 10L: 10m
--------------	--	--	---	--

**RCX340-4**

<b>Controller / Number of controllable axes</b>	<b>Safety standard</b>	<b>Option A (OP.A)</b>	<b>Option B (OP.B)</b>	<b>Option C (OP.C)</b>	<b>Option D (OP.D)</b>	<b>Option E (OP.E)</b>	<b>Absolute battery</b>
---	------------------------	------------------------	------------------------	------------------------	------------------------	------------------------	-------------------------

**Specify various controller setting items. RCX340 ▶ P.508**

**RCX240**

<b>Controller</b>	<b>CE Marking</b>	<b>Regenerative unit</b>	<b>Expansion I/O</b>	<b>Network option</b>	<b>IVY System</b>	<b>Gripper</b>	<b>Battery</b>
-------------------	-------------------	--------------------------	----------------------	-----------------------	-------------------	----------------	----------------

**Specify various controller setting items. RCX240/RCX240S ▶ P.495**

Note 1. When installing the robot, always follow the specifications.  
Do not install the ceiling-mount robot upside down or do not install the inverse type robot to a ceiling.  
Incorrect installation can cause trouble or malfunction.

## Specifications

Axis specifications	Arm length	X-axis	Y-axis	Z-axis	R-axis
<b>Rotation angle</b>		500 mm	400 mm	200 mm/400 mm	-
<b>AC servo motor output</b>		+/-130 °	+/-150 °	-	+/-360 °
<b>Deceleration mechanism</b>	<b>Speed reducer</b>	750 W	400 W	400 W	200 W
	<b>Transmission method</b>	Harmonic drive	Harmonic drive	Ball screw	Harmonic drive
	<b>Motor to speed reducer</b>			Direct-coupled	
	<b>Speed reducer to output</b>			Direct-coupled	
<b>Repeatability</b> <sup>Note 1</sup>		+/-0.02 mm	+/-0.01 mm		+/-0.004 °
<b>Maximum speed</b>		9.9 m/sec	2.3 m/sec	1.7 m/sec	920 °/sec (wall-mount) 480 °/sec (inverse wall-mount)
<b>Maximum payload</b>		20 kg (Standard specification), 19 kg (Option specifications)			
<b>Standard cycle time: with 2kg payload</b> <sup>Note 2</sup>		0.49 sec			
<b>R-axis tolerable moment of inertia</b> <sup>Note 3</sup>		1.0 kgm <sup>2</sup>			
<b>User wiring</b>		0.2 sq × 20 wires			
<b>User tubing (Outer diameter)</b>		φ 6 × 3			
<b>Travel limit</b>		1. Soft limit 2. Mechanical stopper (X,Y,Z axis)			
<b>Robot cable length</b>		Standard: 3.5 m Option: 5 m, 10 m			
<b>Weight</b>		Z axis 200 mm: 54 kg Z axis 400 mm: 56 kg			

Note 1. This is the value at a constant ambient temperature. (X,Y axes)  
Note 2. When reciprocating 300mm in horizontal and 25mm in vertical directions.  
Note 3. There are limits to acceleration coefficient settings. See P.539.  
Note. Please consult YAMAHA when connecting other tubes and cables to the self-supporting machine harness.

## Controller

Controller	Power capacity (VA)	Operation method
RCX340 RCX240-R3	2500	Programming / I/O point trace / Remote command / Operation using RS-232C communication

Note. "Harmonic" and "Harmonic drive" are the registered trademarks of Harmonic Drive Systems Inc.  
Note. The movement range can be limited by changing the positions of X and Y axis mechanical stoppers. (The movement range is set to the maximum at the time of shipment.)  
See our robot manuals (installation manuals) for detailed information.

Our robot manuals (installation manuals) can be downloaded from our website at the address below:  
<http://global.yamaha-motor.com/business/robot/>

## YK900XGS

**Standard type**

80 400 500 114 53 20 20 34 20 21 46 220 25 19 147 219

User tubing 3 (φ6 Blue)  
User tubing 2 (φ6 Red)  
User tubing 1 (φ6 Black)

D-sub connector for user wiring (No.1 to 20 usable)

User tubing 1 (φ6 Black)  
User tubing 2 (φ6 Red)  
User tubing 3 (φ6 Blue)

D-sub connector for user wiring (No.1 to 20 usable)

M4 ground terminal

R27 (Min. cable bending radius) Do not move the cable.

Keep enough space for the maintenance work on the top face of the base.

6-φ14 M12 bolt for installation, 6bolts used

4-φ9

φ8H7 through-hole

75 10 2 197.5 197.5 245 (base size) 51 25

φ65

φ95

φ50 h7 0 -0.025

400

Option: Tool flange mount type

Hollow diameter: φ18 40/10 38/6/2 90

φ6 H7 +0.012 through-hole

View of B

Working envelope of left-handed system

Working envelope of right-handed system

X-axis mechanical stopper position: 132°  
Y-axis mechanical stopper position: 152°

YK900XGS Z200mm Stroke specification  
YK900XGS Z400mm Stroke specification  
Note. Inverse type is installed upside down.

APPLICATION  
Linear conveyor modules  
LCM100

TRANSERVO  
Compact single-axis robots

FLIP-X  
Single-axis robots

PHASER  
Linear motor single-axis robots

XY-X  
Cartesian robots

YK-X  
SCARA robots

YP-X  
Pick & place robots

CLEAN  
CONTROLLER INFORMATION

Orbit / T/Ty type

Small / Medium type

Large type

Wall-mount / Inverse type

Dust-proof & drip-proof type

# YK1000XGS

Wall-mount / inverse type

- Arm length 1000mm
- Maximum payload 20kg

## Ordering method

**YK1000XGS**

Model	Installation method <sup>Note 1</sup>	Z axis stroke	Tool flange	Cable
	W: Wall-mount (same as per external view) U: Inverse wall-mount (upside down)	200: 200mm 400: 400mm	No entry: None F: With tool flange	3L: 3.5m 5L: 5m 10L: 10m

**RCX340-4**

Controller / Number of controllable axes	Safety standard	Option A (OP.A)	Option B (OP.B)	Option C (OP.C)	Option D (OP.D)	Option E (OP.E)	Absolute battery

Specify various controller setting items. RCX340 ▶ **P.508**

**RCX240**

Controller	CE Marking	Regenerative unit	Expansion I/O	Network option	IVY System	Gripper	Battery

Specify various controller setting items. RCX240/RCX240S ▶ **P.495**

Note 1. When installing the robot, always follow the specifications.  
Do not install the ceiling-mount robot upside down or do not install the inverse type robot to a ceiling.  
Incorrect installation can cause trouble or malfunction.

## Specifications

Axis specifications	Arm length	X-axis	Y-axis	Z-axis	R-axis
	600 mm	600 mm	400 mm	200 mm/400 mm	-
	Rotation angle	+/-130 °	+/-150 °	-	+/-360 °
AC servo motor output		750 W	400 W	400 W	200 W
Deceleration mechanism	Speed reducer	Harmonic drive	Harmonic drive	Ball screw	Harmonic drive
	Transmission method	Direct-coupled			
	Motor to speed reducer	Direct-coupled			
	Speed reducer to output	Direct-coupled			
Repeatability <sup>Note 1</sup>		+/-0.02 mm	+/-0.01 mm	+/-0.004 °	
Maximum speed		10.6 m/sec	2.3 m/sec	1.7 m/sec	920 °/sec (wall-mount) 480 °/sec (inverse wall-mount)
Maximum payload		20 kg (Standard specification), 19 kg (Option specifications)			
Standard cycle time: with 2kg payload <sup>Note 2</sup>		0.49 sec			
R-axis tolerable moment of inertia <sup>Note 3</sup>		1.0 kgm <sup>2</sup>			
User wiring		0.2 sq x 20 wires			
User tubing (Outer diameter)		φ 6 x 3			
Travel limit		1. Soft limit 2. Mechanical stopper (X,Y,Z axis)			
Robot cable length		Standard: 3.5 m Option: 5 m, 10 m			
Weight		Z axis 200 mm: 56 kg Z axis 400 mm: 58 kg			

Note 1. This is the value at a constant ambient temperature. (X,Y axes)  
Note 2. When reciprocating 300mm in horizontal and 25mm in vertical directions.  
Note 3. There are limits to acceleration coefficient settings. See P.539.  
Note. Please consult YAMAHA when connecting other tubes and cables to the self-supporting machine harness.

## Controller

Controller	Power capacity (VA)	Operation method
RCX340 RCX240-R3	2500	Programming / I/O point trace / Remote command / Operation using RS-232C communication

Note. "Harmonic" and "Harmonic drive" are the registered trademarks of Harmonic Drive Systems Inc.  
Note. The movement range can be limited by changing the positions of X and Y axis mechanical stoppers. (The movement range is set to the maximum at the time of shipment.)  
See our robot manuals (installation manuals) for detailed information.

Our robot manuals (installation manuals) can be downloaded from our website at the address below:  
<http://global.yamaha-motor.com/business/robot/>

## YK1000XGS

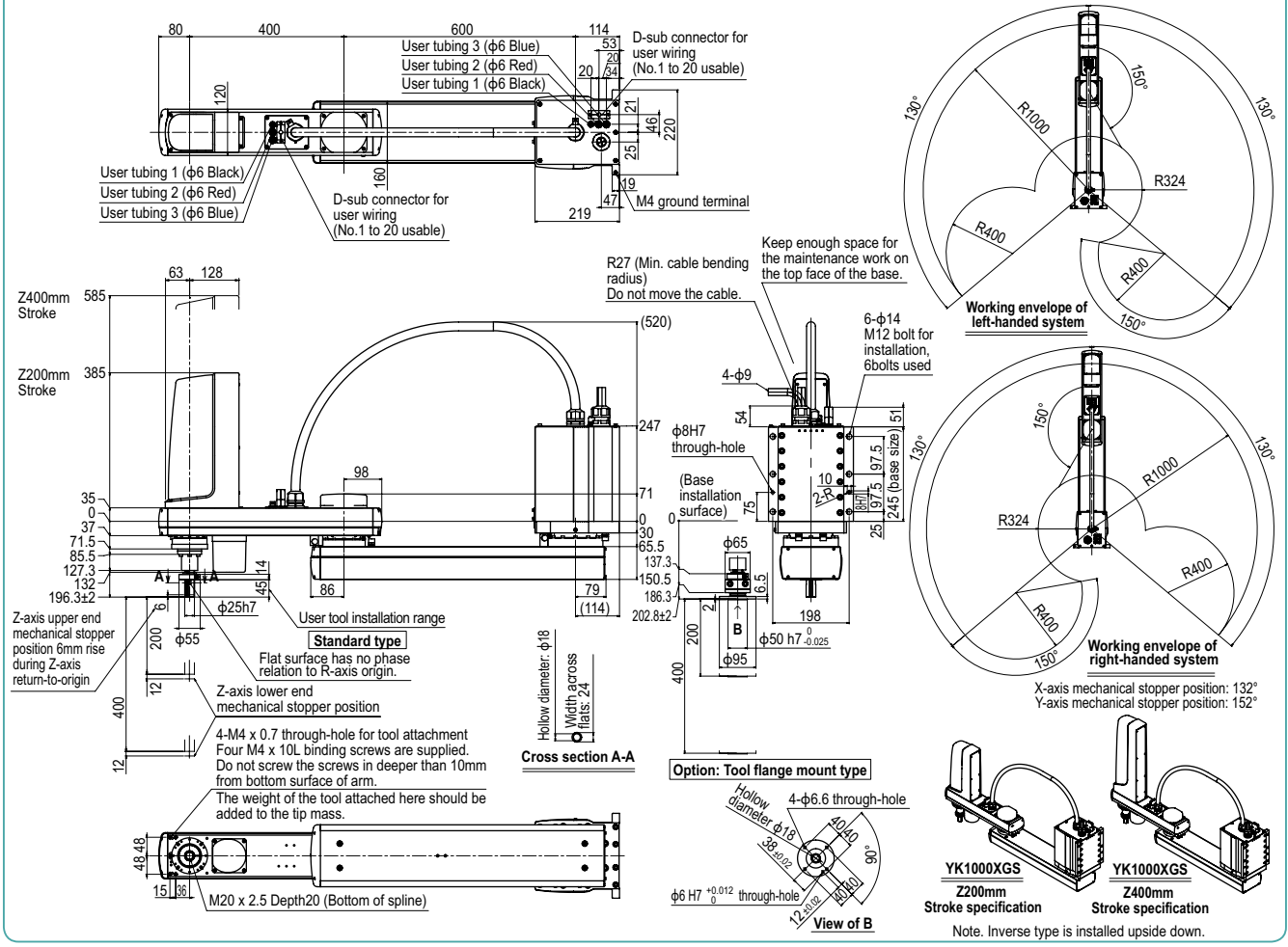

# YK250XGP

Dust-proof & drip-proof type

- Arm length 250mm
- Maximum payload 4kg

## Ordering method

**YK250XGP - 150**

**S**

**Cable**

**RCX340-4**

**Model**  
Z axis stroke  
150: 150mm

**Tool flange**  
No entry: None  
F: With tool flange

**Hollow shaft**  
S: With hollow shaft

**Cable**  
3L: 3.5m  
5L: 5m  
10L: 10m

**Controller / Number of controllable axes**

**Safety standard**

**Option A (OP.A)**

**Option B (OP.B)**

**Option C (OP.C)**

**Option D (OP.D)**

**Option E (OP.E)**

**Absolute battery**

Specify various controller setting items. RCX340 ▶ **P.508**

**RCX240S**

**Controller**

**CE Marking**

**Expansion I/O**

**Network option**

**IVY System**

**Gripper**

**Battery**

Specify various controller setting items. RCX240/RCX240S ▶ **P.495**



## Specifications

		X-axis	Y-axis	Z-axis	R-axis
<b>Axis specifications</b>	<b>Arm length</b>	100 mm	150 mm	150 mm	-
	<b>Rotation angle</b>	+/-129 °	+/-134 °	-	+/-360 °
<b>AC servo motor output (W)</b>		200	150	50	100
<b>Deceleration mechanism</b>	<b>Speed reducer</b>	Harmonic drive	Harmonic drive	Ball screw	Harmonic drive
	<b>Transmission method</b>	Direct-coupled			
	<b>Motor to speed reducer</b> <b>Speed reducer to output</b>	Direct-coupled			
<b>Repeatability</b> <sup>Note 1</sup>		+/-0.01 mm	+/-0.01 mm	+/-0.01 mm	+/-0.004 °
<b>Maximum speed</b>		4.5 m/sec	1.1 m/sec		1020 °/sec
<b>Maximum payload</b>		4 kg			
<b>Standard cycle time: with 2kg payload</b> <sup>Note 2</sup>		0.57 sec			
<b>R-axis tolerable moment of inertia</b> <sup>Note 3</sup>		0.05 kgm <sup>2</sup>			
<b>Protection class</b> <sup>Note 4</sup>		Equivalent to IP65 (IEC 60529)			
<b>User wiring</b>		0.2 sq × 10 wires			
<b>User tubing (Outer diameter)</b>		φ 4 × 4			
<b>Travel limit</b>		1.Soft limit 2.Mechanical stopper (X,Y,Z axis)			
<b>Robot cable length</b>		Standard: 3.5 m Option: 5 m, 10 m			
<b>Weight</b>		21.5 kg			

- Note 1. This is the value at a constant ambient temperature. (X,Y axes)  
 Note 2. When reciprocating 25mm in vertical direction and 300mm in horizontal direction (rough-positioning arch motion).  
 Note 3. There are limits to acceleration coefficient settings. See P.537.  
 Note 4. Do not use robots where the bellows section is directly exposed to water jet. Contact our distributor for information on drip-proof structure preventing liquid other than water.

## Controller

Controller	Power capacity (VA)	Operation method
RCX340 RCX240S	1000	Programming / I/O point trace / Remote command / Operation using RS-232C communication

- Note. "Harmonic" and "Harmonic drive" are the registered trademarks of Harmonic Drive Systems Inc.  
 Note. The movement range can be limited by changing the positions of X and Y axis mechanical stoppers. (The movement range is set to the maximum at the time of shipment.)  
 See our robot manuals (installation manuals) for detailed information.  
 Note. To set the standard coordinates with high accuracy, use a standard coordinate setting jig (option). Refer to the user's manual (installation manual) for more details.

Our robot manuals (installation manuals) can be downloaded from our website at the address below:  
<http://global.yamaha-motor.com/business/robot/>

## YK250XGP

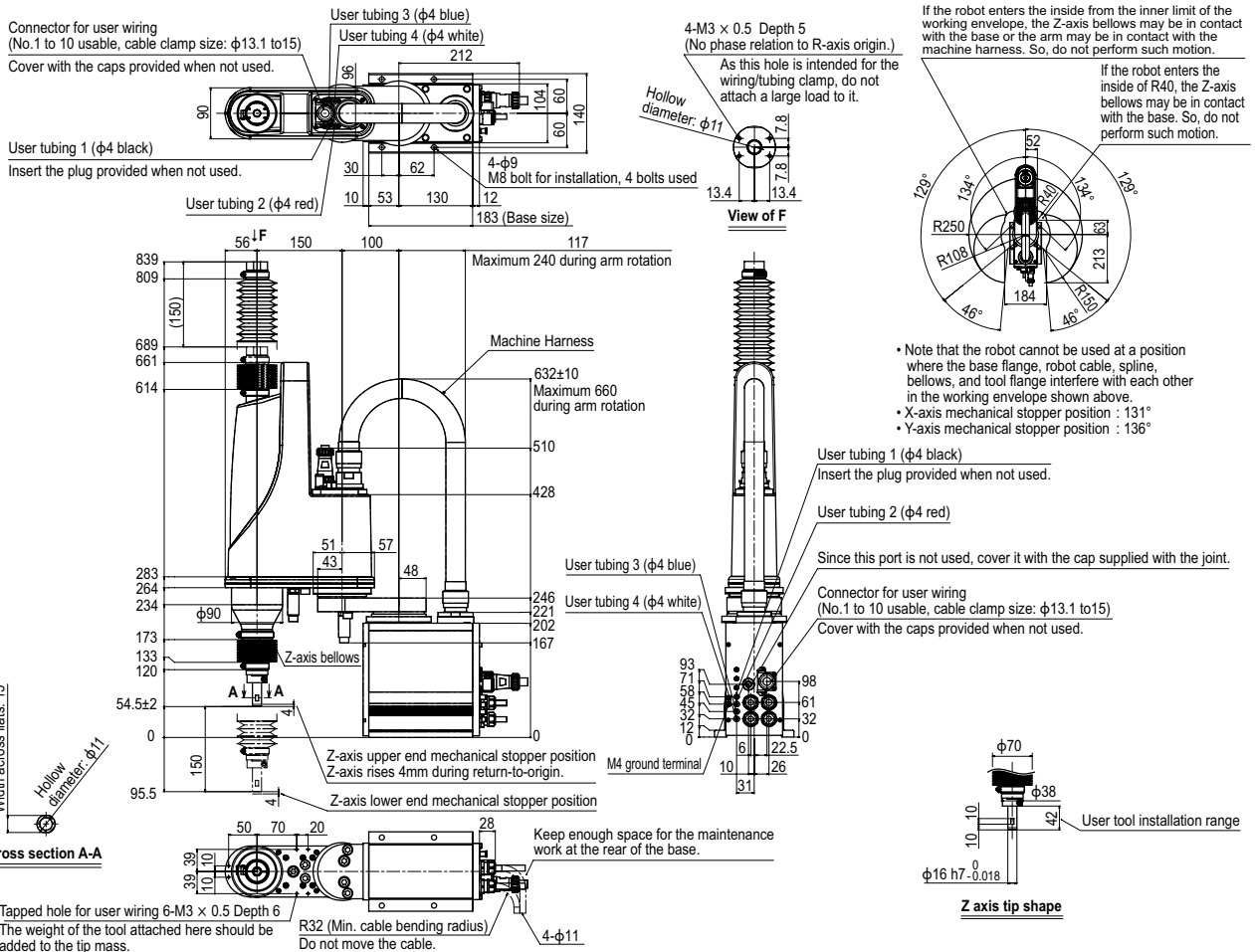

APPLICATION  
 Linear conveyor modules  
 LCM100

TRANSERVO  
 Compact single-axis robots

FLIP-X  
 Single-axis robots

PHASER  
 Linear motor single-axis robots

XX-X  
 Cartesian robots

YK-X  
 SCARA robots

YP-X  
 Pick & place robots

CLEAN  
 CLEAN

CONTROLLER INFORMATION

Orbit / TriV type

Small / Medium type

Large type

Inverse type

Walk-mount / Inverse type

Dust-proof & drip-proof type

## YK250XGP Tool flange mount type

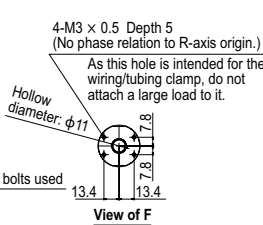
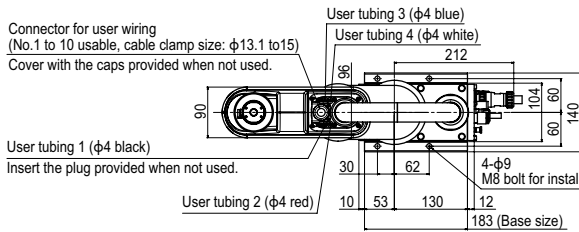

If the robot enters the inside from the inner limit of the working envelope, the Z-axis bellows may be in contact with the base or the arm may be in contact with the machine harness. So, do not perform such motion.

If the robot enters the inside of R40, the Z-axis bellows may be in contact with the base. So, do not perform such motion.

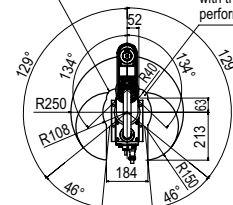

- Note that the robot cannot be used at a position where the base flange, robot cable, spline, bellows, and tool flange interfere with each other in the working envelope shown above.
- X-axis mechanical stopper position : 131°
- Y-axis mechanical stopper position : 136°

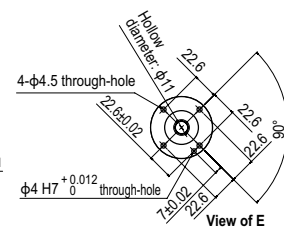
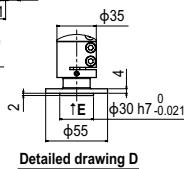
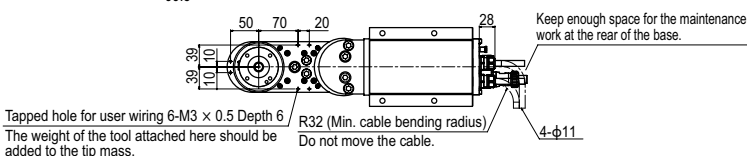
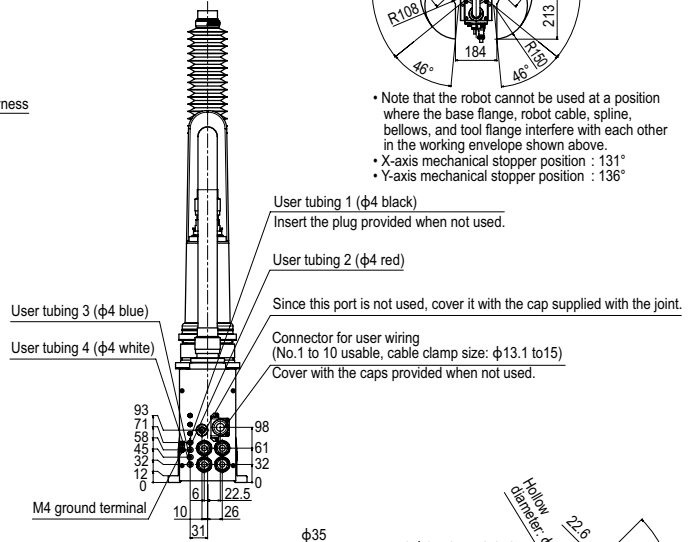
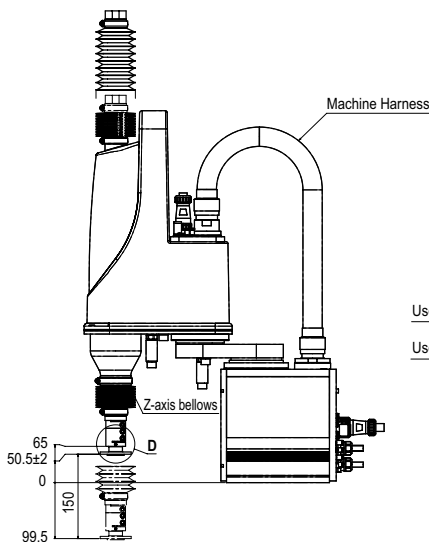

# YK350XGP

**Dust-proof & drip-proof type**

- Arm length 350mm
- Maximum payload 4kg

## Ordering method

**YK350XGP - 150**

<b>Model</b>	<b>Z axis stroke</b>	<b>Tool flange</b>	<b>Hollow shaft</b>	<b>Cable</b>
	150: 150mm	No entry: None F: With tool flange	S: With hollow shaft	3L: 3.5m 5L: 5m 10L: 10m

<b>RCX340-4</b>							
<b>Controller / Number of controllable axes</b>	<b>Safety standard</b>	<b>Option A (OP.A)</b>	<b>Option B (OP.B)</b>	<b>Option C (OP.C)</b>	<b>Option D (OP.D)</b>	<b>Option E (OP.E)</b>	<b>Absolute battery</b>

Specify various controller setting items. RCX340 ▶ **P.508**

<b>RCX240S</b>						<b>BB</b>
<b>Controller</b>	<b>CE Marking</b>	<b>Expansion I/O</b>	<b>Network option</b>	<b>iVY System</b>	<b>Gripper</b>	<b>Battery</b>

Specify various controller setting items. RCX240/RCX240S ▶ **P.495**

## Specifications

		X-axis	Y-axis	Z-axis	R-axis
<b>Axis specifications</b>	<b>Arm length</b>	200 mm	150 mm	150 mm	-
	<b>Rotation angle</b>	+/-129 °	+/-134 °	-	+/-360 °
<b>AC servo motor output</b>		200 W	150 W	50 W	100 W
<b>Deceleration mechanism</b>	<b>Speed reducer</b>	Harmonic drive	Harmonic drive	Ball screw	Harmonic drive
	<b>Transmission method</b>	Direct-coupled			
	<b>Motor to speed reducer / Speed reducer to output</b>	Direct-coupled			
<b>Repeatability</b> <small>Note 1</small>		+/-0.01 mm	+/-0.01 mm	+/-0.004 mm	+/-0.004 °
<b>Maximum speed</b>		5.6 m/sec	1.1 m/sec		1020 °/sec
<b>Maximum payload</b>		4 kg			
<b>Standard cycle time: with 2kg payload</b> <small>Note 2</small>		0.57 sec			
<b>R-axis tolerable moment of inertia</b> <small>Note 3</small>		0.05 kgm <sup>2</sup>			
<b>Protection class</b> <small>Note 4</small>		Equivalent to IP65 (IEC 60529)			
<b>User wiring</b>		0.2 sq × 10 wires			
<b>User tubing (Outer diameter)</b>		φ 4 × 4			
<b>Travel limit</b>		1. Soft limit 2. Mechanical stopper (X,Y,Z axis)			
<b>Robot cable length</b>		Standard: 3.5 m Option: 5 m, 10 m			
<b>Weight</b>		22 kg			

Note 1. This is the value at a constant ambient temperature. (X,Y axes)  
 Note 2. When reciprocating 25mm in vertical direction and 300mm in horizontal direction (rough-positioning arch motion).  
 Note 3. There are limits to acceleration coefficient settings. See P.537.  
 Note 4. Do not use robots where the bellows section is directly exposed to water jet. Contact our distributor for information on drip-proof structure preventing liquid other than water.

## Controller

Controller	Power capacity (VA)	Operation method
RCX340 RCX240S	1000	Programming / I/O point trace / Remote command / Operation using RS-232C communication

Note. "Harmonic" and "Harmonic drive" are the registered trademarks of Harmonic Drive Systems Inc.  
 Note. The movement range can be limited by changing the positions of X and Y axis mechanical stoppers. (The movement range is set to the maximum at the time of shipment.)  
 See our robot manuals (installation manuals) for detailed information.  
 Note. To set the standard coordinates with high accuracy, use a standard coordinate setting jig (option). Refer to the user's manual (installation manual) for more details.

Our robot manuals (installation manuals) can be downloaded from our website at the address below:  
<http://global.yamaha-motor.com/business/robot/>

## YK350XGP

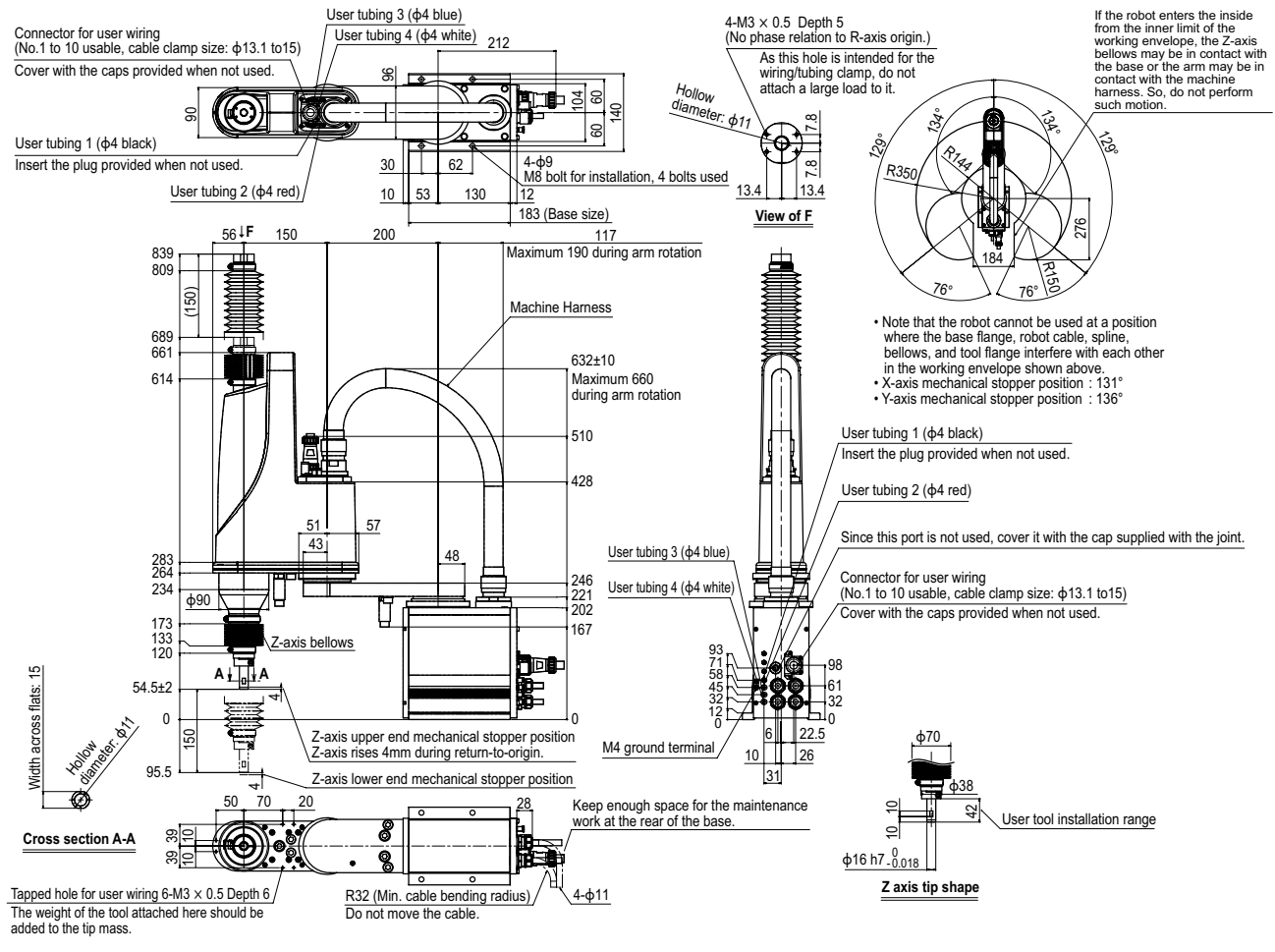

APPLICATION  
 Linear conveyor  
 modules  
 LCM100  
 TRANSEURO  
 Compact  
 single-axis robots  
 FLIP-X  
 Single-axis robots  
 PHASER  
 Linear motor  
 single-axis robots  
 Cartesian  
 robots  
 XX-X  
 SCARA  
 robots  
 YK-X  
 Pick & place  
 robots  
 YP-X  
 CLEAN  
 CONTROLLER INFORMATION  
 Orbit / Triv  
 type  
 Small /  
 Medium type  
 Large type  
 Inverse type  
 Walk-mount /  
 Inverse type  
 Dust-proof  
 & drip-proof  
 type

## YK350XGP Tool flange mount type

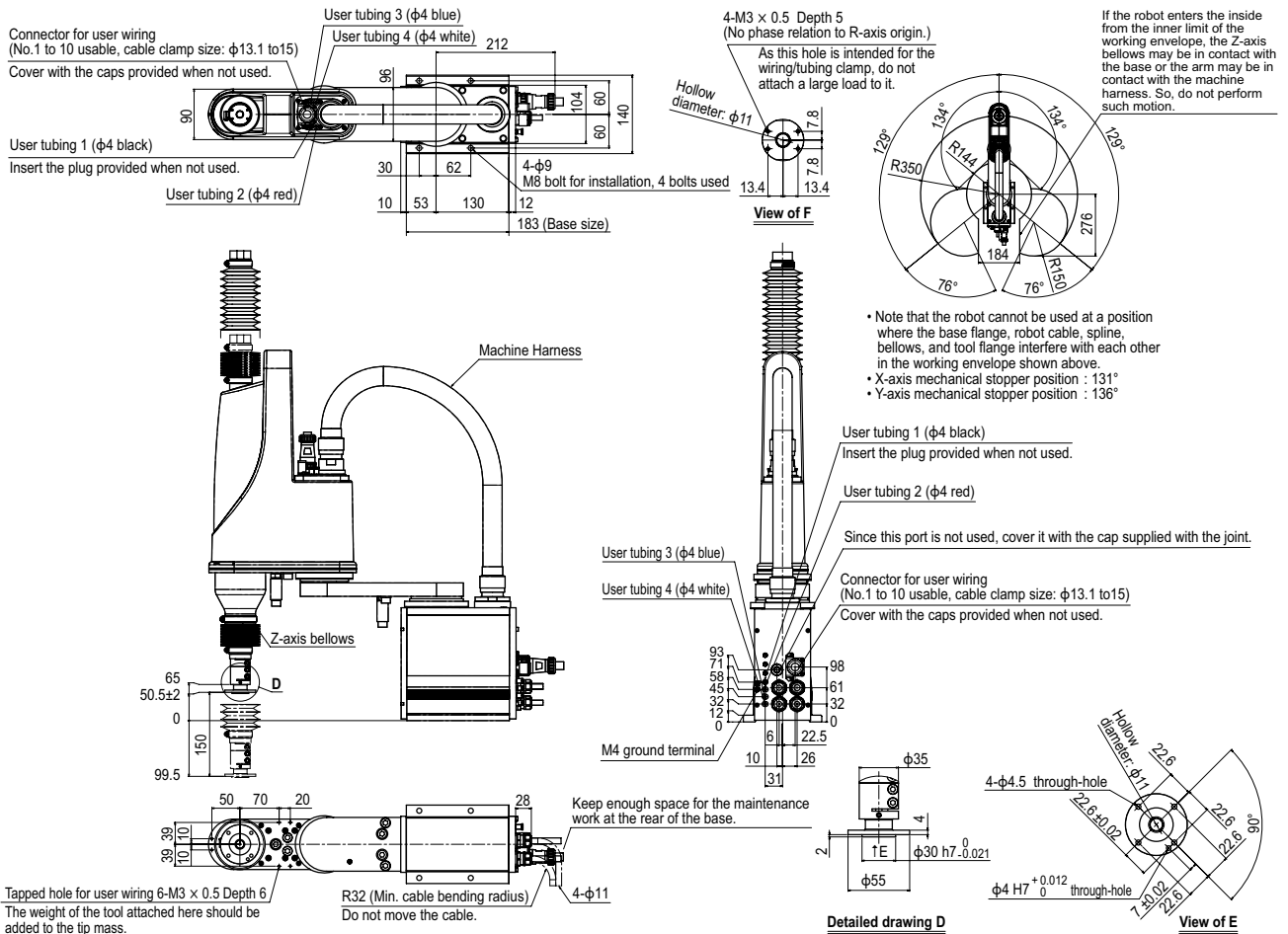

# YK400XGP

Dust-proof & drip-proof type

- Arm length 400mm
- Maximum payload 4kg

## Ordering method

**YK400XGP - 150**

<b>Model</b>	<b>Z axis stroke</b> 150: 150mm	<b>Tool flange</b> No entry: None F: With tool flange	<b>Hollow shaft</b> S: With hollow shaft	<b>Cable</b> 3L: 3.5m 5L: 5m 10L: 10m
--------------	------------------------------------	---	---	--

**S**

**RCX340-4**

<b>Controller / Number of controllable axes</b>	<b>Safety standard</b>	<b>Option A (OP.A)</b>	<b>Option B (OP.B)</b>	<b>Option C (OP.C)</b>	<b>Option D (OP.D)</b>	<b>Option E (OP.E)</b>	<b>Absolute battery</b>
---	------------------------	------------------------	------------------------	------------------------	------------------------	------------------------	-------------------------

Specify various controller setting items. RCX340 ▶ **P.508**

**RCX240S**

<b>Controller</b>	<b>CE Marking</b>	<b>Expansion I/O</b>	<b>Network option</b>	<b>IVY System</b>	<b>Gripper</b>	<b>Battery</b>
-------------------	-------------------	----------------------	-----------------------	-------------------	----------------	----------------

Specify various controller setting items. RCX240/RCX240S ▶ **P.495**

## Specifications

		X-axis	Y-axis	Z-axis	R-axis
<b>Axis specifications</b>	<b>Arm length</b>	250 mm	150 mm	150 mm	-
	<b>Rotation angle</b>	+/-129 °	+/-144 °	-	+/-360 °
<b>AC servo motor output</b>		200 W	150 W	50 W	100 W
<b>Deceleration mechanism</b>	<b>Speed reducer</b>	Harmonic drive	Harmonic drive	Ball screw	Harmonic drive
	<b>Transmission method</b>	Direct-coupled			
	<b>Motor to speed reducer</b> <b>Speed reducer to output</b>	Direct-coupled			
<b>Repeatability</b> <small>Note 1</small>	+/-0.01 mm		+/-0.01 mm	+/-0.004 °	
<b>Maximum speed</b>		6.1 m/sec	1.1 m/sec	1020 °/sec	
<b>Maximum payload</b>		4 kg			
<b>Standard cycle time: with 2kg payload</b> <small>Note 2</small>		0.57 sec			
<b>R-axis tolerable moment of inertia</b> <small>Note 3</small>		0.05 kgm <sup>2</sup>			
<b>Protection class</b> <small>Note 4</small>		Equivalent to IP65 (IEC 60529)			
<b>User wiring</b>		0.2 sq × 10 wires			
<b>User tubing (Outer diameter)</b>		φ 4 × 4			
<b>Travel limit</b>		1. Soft limit 2. Mechanical stopper (X,Y,Z axis)			
<b>Robot cable length</b>		Standard: 3.5 m Option: 5 m, 10 m			
<b>Weight</b>		22.5 kg			

Note 1. This is the value at a constant ambient temperature. (X,Y axes)  
 Note 2. When reciprocating 25mm in vertical direction and 300mm in horizontal direction (rough-positioning arch motion).  
 Note 3. There are limits to acceleration coefficient settings. See P.538.  
 Note 4. Do not use robots where the bellows section is directly exposed to water jet. Contact our distributor for information on drip-proof structure preventing liquid other than water.

## Controller

Controller	Power capacity (VA)	Operation method
RCX340 RCX240S	1000	Programming / I/O point trace / Remote command / Operation using RS-232C communication

Note. "Harmonic" and "Harmonic drive" are the registered trademarks of Harmonic Drive Systems Inc.  
 Note. The movement range can be limited by changing the positions of X and Y axis mechanical stoppers. (The movement range is set to the maximum at the time of shipment.)  
 See our robot manuals (installation manuals) for detailed information.  
 Note. To set the standard coordinates with high accuracy, use a standard coordinate setting jig (option). Refer to the user's manual (installation manual) for more details.

Our robot manuals (installation manuals) can be downloaded from our website at the address below:  
<http://global.yamaha-motor.com/business/robot/>

## YK400XGP

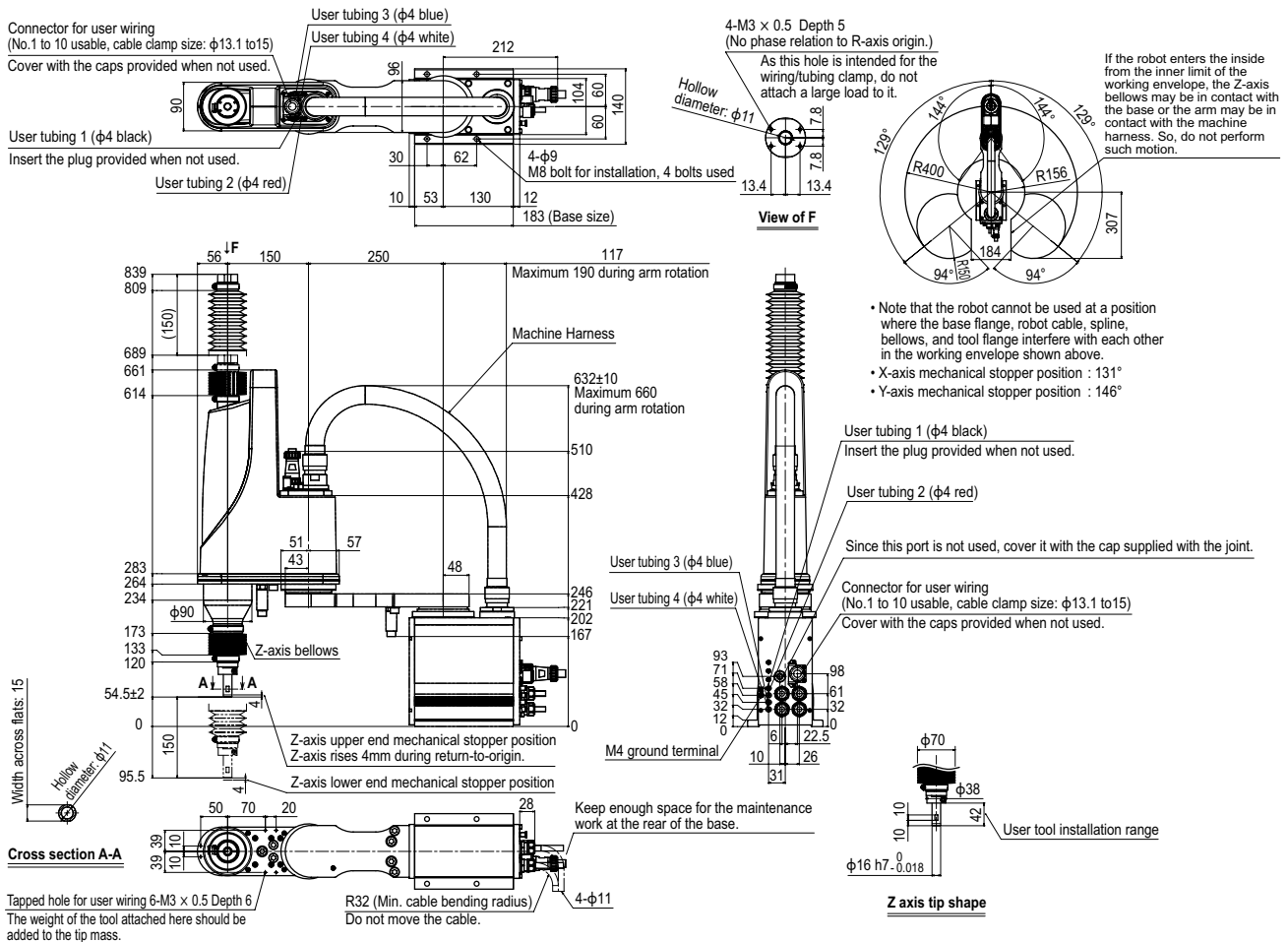



## YK400XGP Tool flange mount type

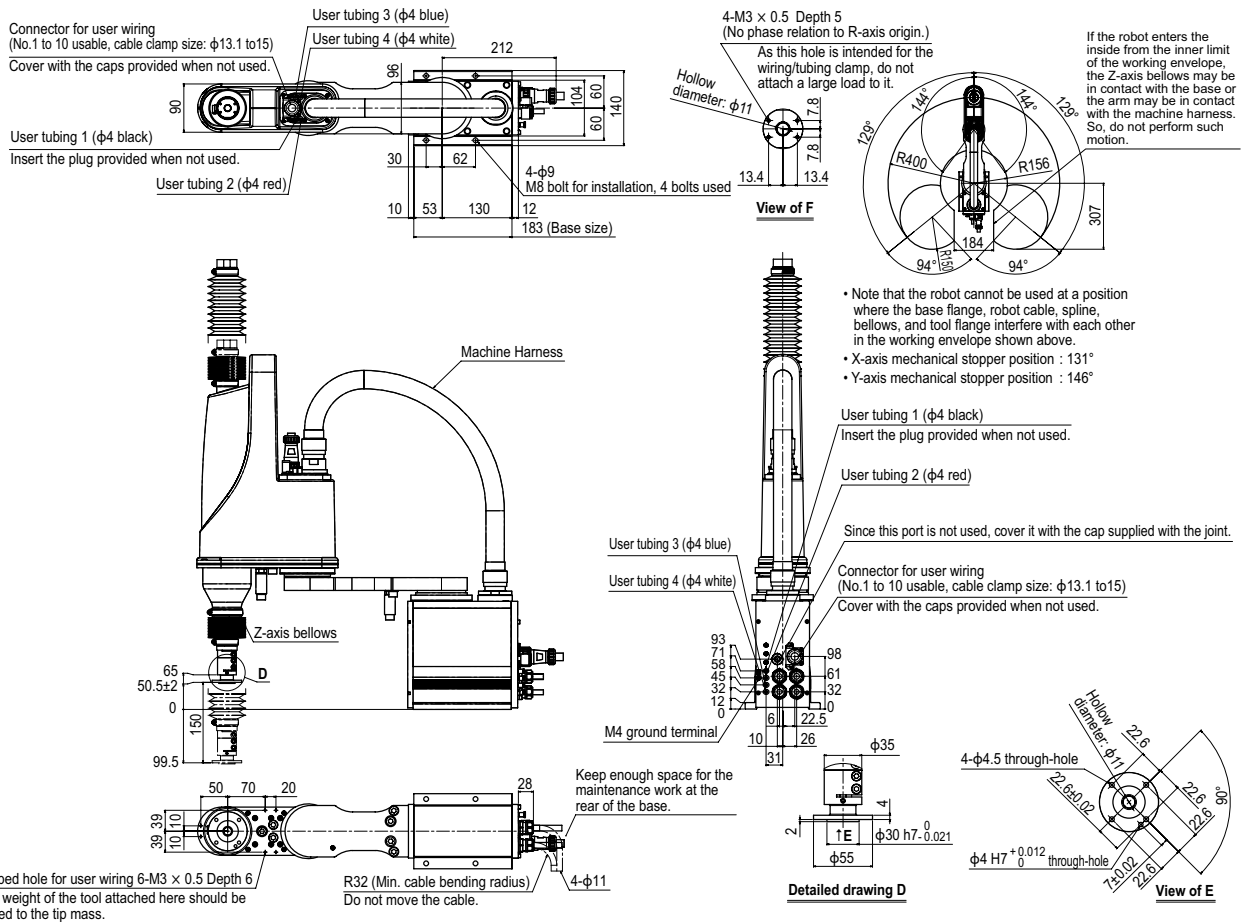

# YK500XGLP

Dust-proof & drip-proof type

- Arm length 500mm
- Maximum payload 4kg

## Ordering method

**YK500XGLP-150** **S** **RCX340-4**

Model      Z axis stroke: 150: 150mm      Tool flange: No entry: None, F: With tool flange      Hollow shaft: S: With hollow shaft      Cable: 3L: 3.5m, 5L: 5m, 10L: 10m

Controller / Number of controllable axes: RCX340-4      Safety standard      Option A (OP.A)      Option B (OP.B)      Option C (OP.C)      Option D (OP.D)      Option E (OP.E)      Absolute battery

Specify various controller setting items. RCX340 ▶ **P.508**

**RCX240S**      CE Marking      Expansion I/O      Network option      IVY System      Gripper      Battery **BB**

Controller      CE Marking      Expansion I/O      Network option      IVY System      Gripper      Battery

Specify various controller setting items. RCX240/RCX240S ▶ **P.495**

## Specifications

		X-axis	Y-axis	Z-axis	R-axis
Axis specifications	Arm length	250 mm	250 mm	150 mm	-
	Rotation angle	+/-129 °	+/-144 °	-	+/-360 °
AC servo motor output		200 W	150 W	50 W	100 W
Deceleration mechanism	Speed reducer	Harmonic drive	Harmonic drive	Ball screw	Harmonic drive
	Transmission method	Direct-coupled			
	Motor to speed reducer / Speed reducer to output	Direct-coupled			
Repeatability <sup>Note 1</sup>		+/-0.01 mm	+/-0.01 mm	+/-0.01 mm	+/-0.004 °
Maximum speed		5.1 m/sec		1.1 m/sec	1020 °/sec
Maximum payload		4 kg			
Standard cycle time: with 2kg payload <sup>Note 2</sup>		0.74 sec			
R-axis tolerable moment of inertia <sup>Note 3</sup>		0.05 kgm <sup>2</sup>			
Protection class <sup>Note 4</sup>		Equivalent to IP65 (IEC 60529)			
User wiring		0.2 sq × 10 wires			
User tubing (Outer diameter)		φ 4 × 4			
Travel limit		1.Soft limit 2.Mechanical stopper (X,Y,Z axis)			
Robot cable length		Standard: 3.5 m Option: 5 m, 10 m			
Weight		25 kg			

- Note 1. This is the value at a constant ambient temperature. (X,Y axes)  
 Note 2. When reciprocating 25mm in vertical direction and 300mm in horizontal direction (rough-positioning arch motion).  
 Note 3. There are limits to acceleration coefficient settings. See P.538.  
 Note 4. Do not use robots where the bellows section is directly exposed to water jet. Contact our distributor for information on drip-proof structure preventing liquid other than water.

## Controller

Controller	Power capacity (VA)	Operation method
RCX340 RCX240S	1000	Programming / I/O point trace / Remote command / Operation using RS-232C communication

- Note. "Harmonic" and "Harmonic drive" are the registered trademarks of Harmonic Drive Systems Inc.  
 Note. The movement range can be limited by changing the positions of X and Y axis mechanical stoppers. (The movement range is set to the maximum at the time of shipment.)  
 See our robot manuals (installation manuals) for detailed information.  
 Note. To set the standard coordinates with high accuracy, use a standard coordinate setting jig (option). Refer to the user's manual (installation manual) for more details.

Our robot manuals (installation manuals) can be downloaded from our website at the address below:  
<http://global.yamaha-motor.com/business/robot/>

## YK500XGLP

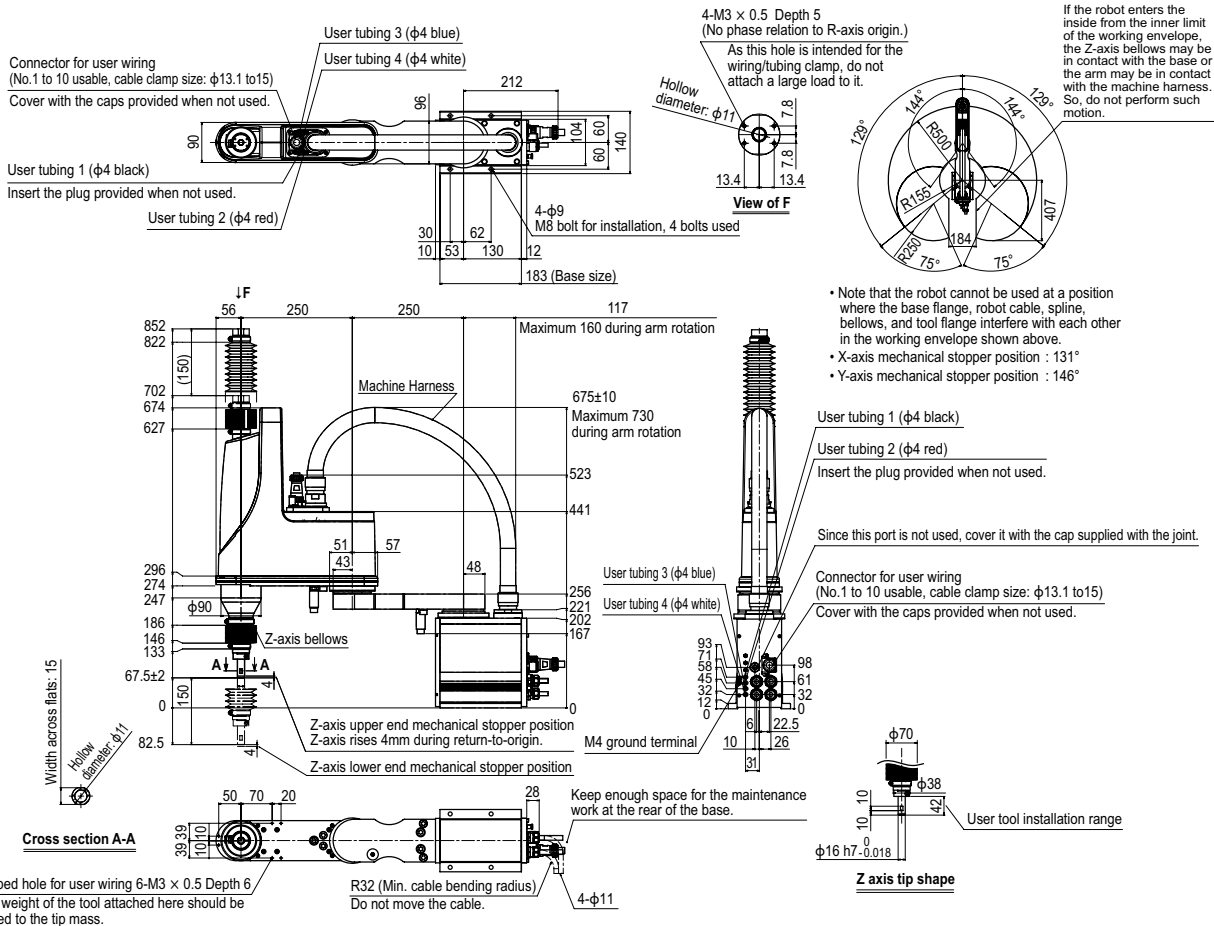

APPLICATION  
 Linear conveyor / modules  
 LCM100  
 Compact single-axis robots  
 TRANSERVO  
 Single-axis robots  
 FLIP-X  
 Linear motor single-axis robots  
 PHASER  
 Cartesian robots  
 XX-X  
 SCARA robots  
 YK-X  
 Pick & place robots  
 YP-X  
 CLEAN  
 CONTROLLER INFORMATION  
 Orbit / T/Try type  
 Small / Medium type  
 Large type  
 Inverse type  
 Walk-mount / Inverse type  
 Dust-proof & drip-proof type

## YK500XGLP Tool flange mount type

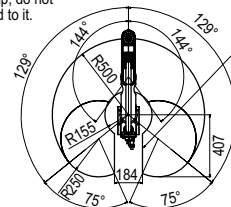
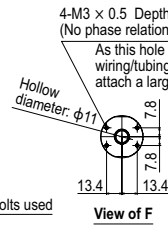
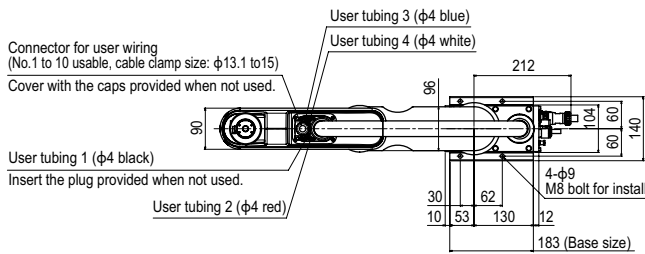

If the robot enters the inside from the inner limit of the working envelope, the Z-axis bellows may be in contact with the base or the arm may be in contact with the machine harness. So, do not perform such motion.

- Note that the robot cannot be used at a position where the base flange, robot cable, spline, bellows, and tool flange interfere with each other in the working envelope shown above.
- X-axis mechanical stopper position : 131°
- Y-axis mechanical stopper position : 146°

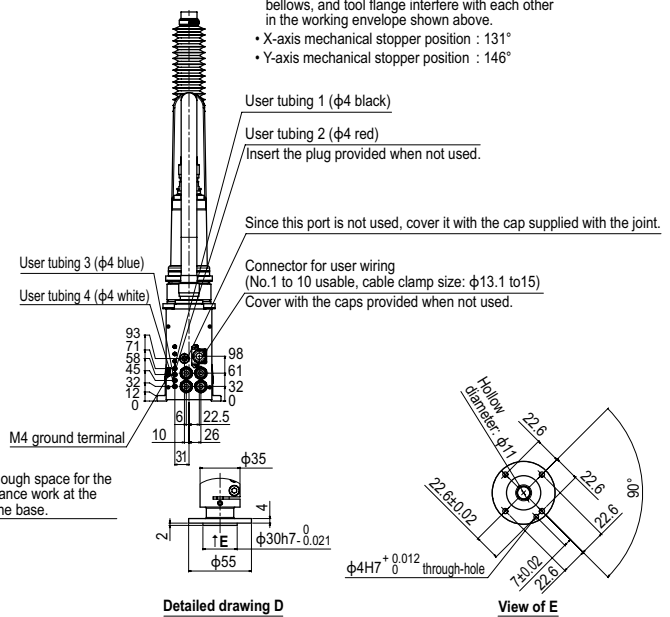
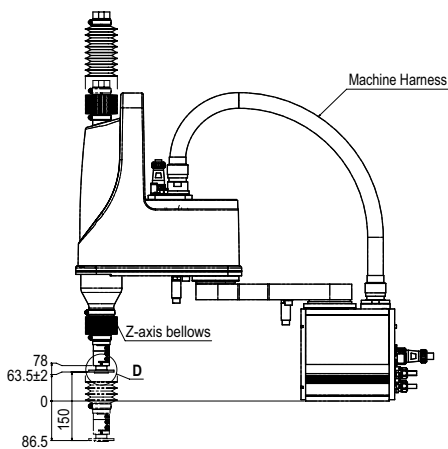

Tapped hole for user wiring 6-M3 x 0.5 Depth 6  
The weight of the tool attached here should be added to the tip mass.

R32 (Min. cable bending radius)  
Do not move the cable.

4- $\phi 11$

# YK500XGP

Dust-proof & drip-proof type

- Arm length 500mm
- Maximum payload 8kg

## Ordering method

**YK500XGP** **F** **RCX340-4**

<b>Model</b>	<b>Z axis stroke</b>	<b>Tool flange</b>	<b>Cable</b>	<b>Controller / Number of controllable axes</b>	<b>Safety standard</b>	<b>Option A (OP.A)</b>	<b>Option B (OP.B)</b>	<b>Option C (OP.C)</b>	<b>Option D (OP.D)</b>	<b>Option E (OP.E)</b>	<b>Absolute battery</b>
	200: 200mm 300: 300mm	F: With tool flange	3L: 3.5m 5L: 5m 10L: 10m	<b>Specify various controller setting items. RCX340 ▶ P.508</b>							

**RCX240** **R3** **BB**

<b>Controller</b>	<b>CE Marking</b>	<b>Regenerative unit</b>	<b>Expansion I/O</b>	<b>Network option</b>	<b>iVY System</b>	<b>Gripper</b>	<b>Battery</b>
<b>Specify various controller setting items. RCX240/RCX240S ▶ P.495</b>							

## Specifications

		X-axis	Y-axis	Z-axis	R-axis
<b>Axis specifications</b>	<b>Arm length</b>	200 mm	300 mm	200 mm/300 mm	—
	<b>Rotation angle</b>	+/-130 °	+/-145 °	—	+/-360 °
<b>AC servo motor output</b>		400 W	200 W	200 W	200 W
<b>Deceleration mechanism</b>	<b>Speed reducer</b>	Harmonic drive	Harmonic drive	Ball screw	Harmonic drive
	<b>Transmission method</b>	Direct-coupled			
	<b>Motor to speed reducer</b>	Direct-coupled			
	<b>Speed reducer to output</b>	Direct-coupled			
<b>Repeatability</b> <small>Note 1</small>		+/-0.01 mm	+/-0.01 mm	+/-0.01 mm	+/-0.004 °
<b>Maximum speed</b>		7.6 m/sec	2.3 m/sec	1.7 m/sec	1700 °/sec
<b>Maximum payload</b>		8 kg			
<b>Standard cycle time: with 2kg payload</b> <small>Note 2</small>		0.55 sec			
<b>R-axis tolerable moment of inertia</b> <small>Note 3</small>		0.3 kgm <sup>2</sup>			
<b>Protection class</b> <small>Note 4</small>		Equivalent to IP65 (IEC 60529)			
<b>User wiring</b>		0.2 sq × 20 wires			
<b>User tubing (Outer diameter)</b>		φ 6 × 3			
<b>Travel limit</b>		1.Soft limit 2.Mechanical stopper (X,Y,Z axis)			
<b>Robot cable length</b>		Standard: 3.5 m Option: 5 m, 10 m			
<b>Weight</b>		Z axis 200 mm: 32 kg Z axis 300 mm: 33 kg			

Note 1. This is the value at a constant ambient temperature. (X,Y axes)  
 Note 2. When reciprocating 25mm in vertical direction and 300mm in horizontal direction (rough-positioning arch motion).  
 Note 3. There are limits to acceleration coefficient settings. See P.539.  
 Note 4. Do not use robots where the bellows section is directly exposed to water jet. Contact our distributor for information on drip-proof structure preventing liquid other than water.

## Controller

Controller	Power capacity (VA)	Operation method
RCX340 RCX240-R3	1700	Programming / I/O point trace / Remote command / Operation using RS-232C communication

Note. "Harmonic" and "Harmonic drive" are the registered trademarks of Harmonic Drive Systems Inc.

Note. The movement range can be limited by changing the positions of X and Y axis mechanical stoppers. (The movement range is set to the maximum at the time of shipment.) See our robot manuals (installation manuals) for detailed information.

Note. To set the standard coordinates with high accuracy, use a standard coordinate setting jig (option). Refer to the user's manual (installation manual) for more details.

Our robot manuals (installation manuals) can be downloaded from our website at the address below:  
<http://global.yamaha-motor.com/business/robot/>

## YK500XGP

Connector for user wiring (No.1 to 20 usable, cable clamp size: φ16 to 18)

Cover with the caps provided when not used.

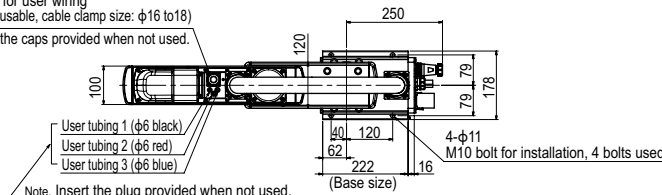

Note. Insert the plug provided when not used.

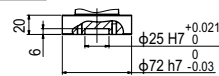
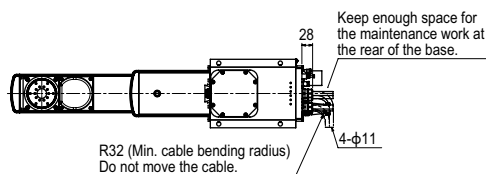
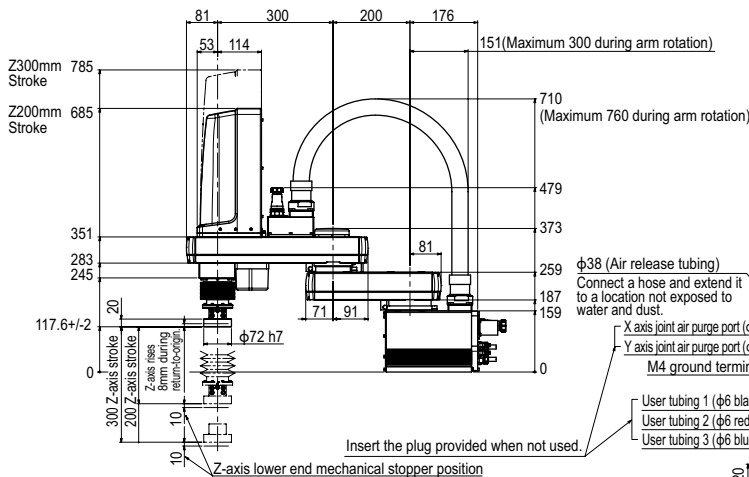

Z axis tip shape

If the robot enters the inside of the corner of dimensions 135 and 292, the Z-axis tip flange may be in contact with the base or the arm may be in contact with the machine harness. So, do not perform such motion.

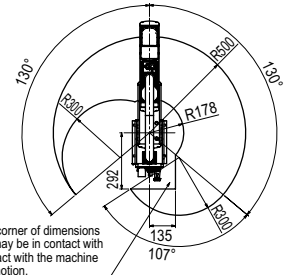

Working envelope of left-handed system

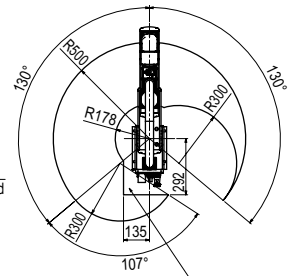

Working envelope of right-handed system

• Note that the robot cannot be used at a position where the base flange, robot cable, spline, and bellows interfere with each other in the working envelope shown above.

- X-axis mechanical stopper position : 132°
- Y-axis mechanical stopper position : 147°

\* There is no phase relation between each position of M5 tapped holes and R-axis origin position.

# YK600XGLP

Dust-proof & drip-proof type

- Arm length 600mm
- Maximum payload 4kg

## Ordering method

**YK600XGLP-150**

**S**

**RCX340-4**

Model	Z axis stroke	Tool flange	Hollow shaft	Cable
	150: 150mm	No entry: None F: With tool flange	S: With hollow shaft	3L: 3.5m 5L: 5m 10L: 10m

Controller / Number of controllable axes	Safety standard	Option A (OP.A)	Option B (OP.B)	Option C (OP.C)	Option D (OP.D)	Option E (OP.E)	Absolute battery

Controller	CE Marking	Expansion I/O	Network option	IVY System	Gripper	Battery
<b>RCX240S</b>						<b>BB</b>

Specify various controller setting items. RCX340 ▶ **P.508**

Specify various controller setting items. RCX240/RCX240S ▶ **P.495**

## Specifications

		X-axis	Y-axis	Z-axis	R-axis
Axis specifications	Arm length	350 mm	250 mm	150 mm	-
	Rotation angle	+/-129 °	+/-144 °	-	+/-360 °
AC servo motor output		200 W	150 W	50 W	100 W
Deceleration mechanism	Speed reducer	Harmonic drive	Harmonic drive	Ball screw	Harmonic drive
	Transmission method	Direct-coupled			
	Motor to speed reducer	Direct-coupled			
	Speed reducer to output	Direct-coupled			
Repeatability <sup>Note 1</sup>		+/-0.01 mm	+/-0.01 mm		+/-0.004 °
Maximum speed		4.9 m/sec		1.1 m/sec	1020 °/sec
Maximum payload		4 kg			
Standard cycle time: with 2kg payload <sup>Note 2</sup>		0.74 sec			
R-axis tolerable moment of inertia <sup>Note 3</sup>		0.05 kgm <sup>2</sup>			
Protection class <sup>Note 4</sup>		Equivalent to IP65 (IEC 60529)			
User wiring (sq × wires)		0.2 × 10			
User tubing (Outer diameter)		φ 4 × 4			
Travel limit		1.Soft limit 2.Mechanical stopper (X,Y,Z axis)			
Robot cable length		Standard: 3.5 m Option: 5 m, 10 m			
Weight		26 kg			

Note 1. This is the value at a constant ambient temperature. (X,Y axes)  
 Note 2. When reciprocating 25mm in vertical direction and 300mm in horizontal direction (rough-positioning arch motion).  
 Note 3. There are limits to acceleration coefficient settings. See P.538.  
 Note 4. Do not use robots where the bellows section is directly exposed to water jet. Contact our distributor for information on drip-proof structure preventing liquid other than water.

## Controller

Controller	Power capacity (VA)	Operation method
RCX340 RCX240S	1000	Programming / I/O point trace / Remote command / Operation using RS-232C communication

Note. "Harmonic" and "Harmonic drive" are the registered trademarks of Harmonic Drive Systems Inc.  
 Note. The movement range can be limited by changing the positions of X and Y axis mechanical stoppers. (The movement range is set to the maximum at the time of shipment.)  
 See our robot manuals (installation manuals) for detailed information.  
 Note. To set the standard coordinates with high accuracy, use a standard coordinate setting jig (option). Refer to the user's manual (installation manual) for more details.

Our robot manuals (installation manuals) can be downloaded from our website at the address below:  
<http://global.yamaha-motor.com/business/robot/>

## YK600XGLP

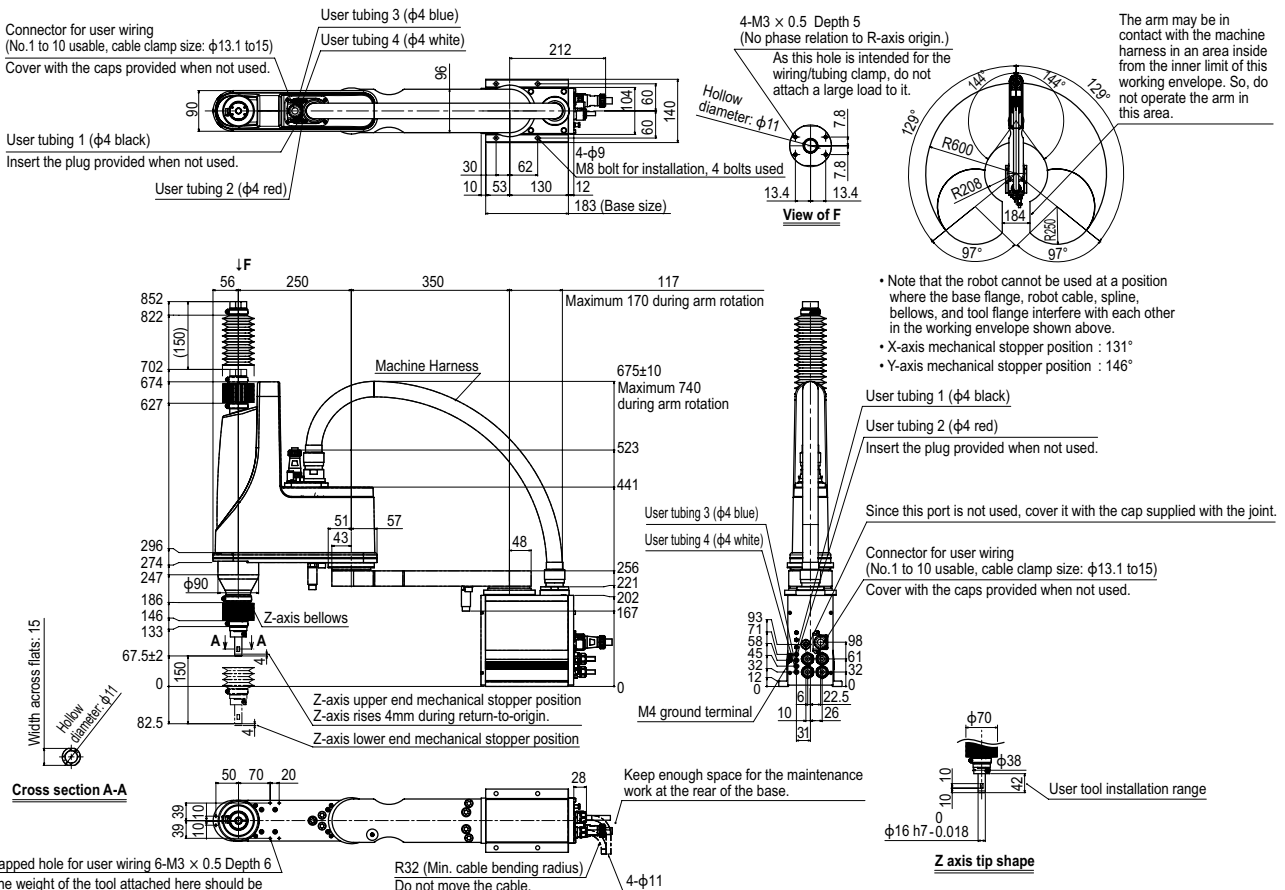

## YK600XGLP Tool flange mount type

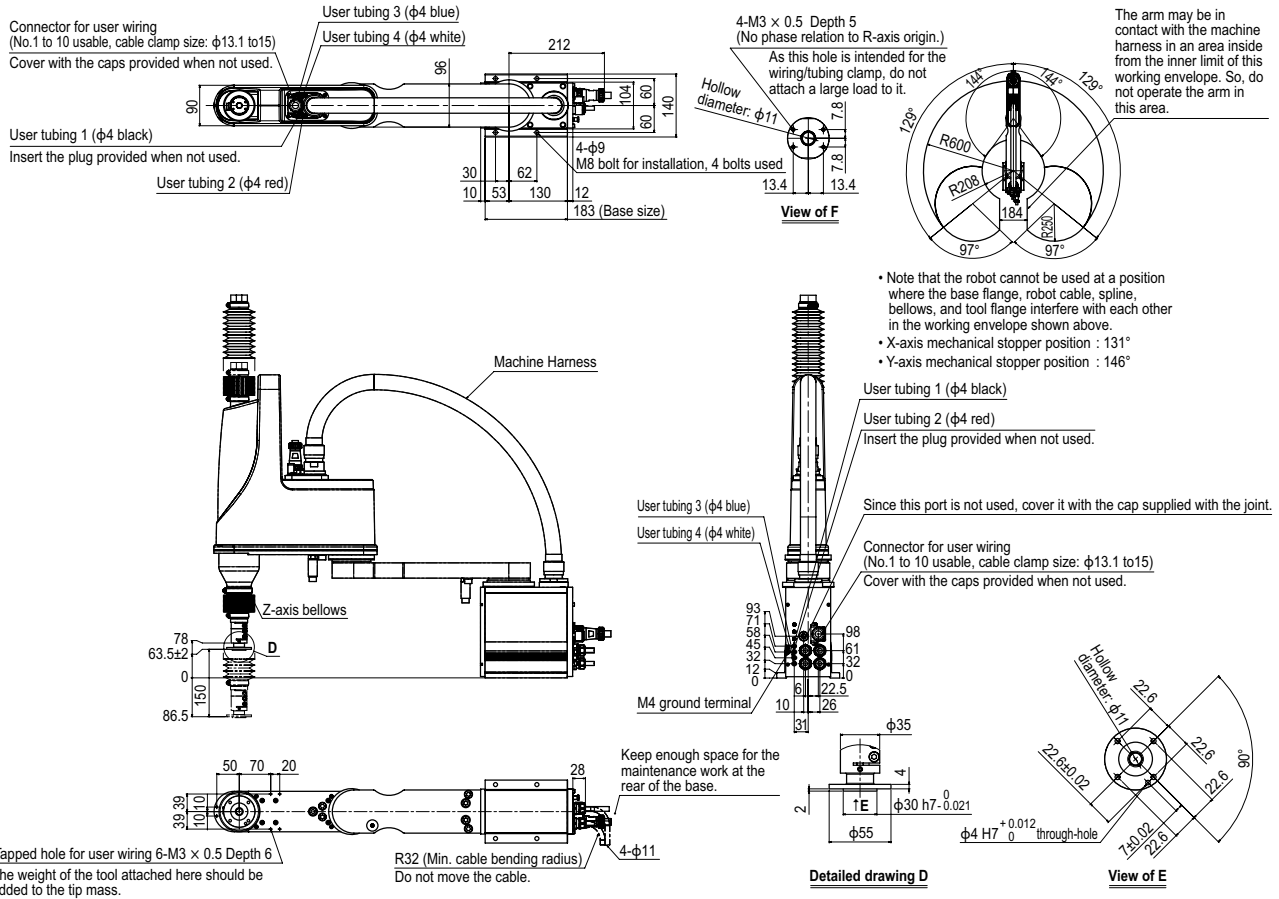

# YK600XGP

Dust-proof & drip-proof type

- Arm length 600mm
- Maximum payload 8kg

## Ordering method

**YK600XGP** **F** **RCX340-4**

Model      Z axis stroke      Tool flange      Cable

200: 200mm      F: With tool flange      3L: 3.5m      Controller / Number of controllable axes

300: 300mm      5L: 5m      10L: 10m      Safety standard      Option A (OP.A)      Option B (OP.B)      Option C (OP.C)      Option D (OP.D)      Option E (OP.E)      Absolute battery

**RCX240** **R3** **BB**

Controller      CE Marking      Regenerative unit      Expansion I/O      Network option      iVY System      Gripper      Battery

Specify various controller setting items. RCX340 ▶ **P.508**

Specify various controller setting items. RCX240/RCX240S ▶ **P.495**

## Specifications

		X-axis	Y-axis	Z-axis	R-axis
Axis specifications	Arm length	300 mm	300 mm	200 mm 300 mm	—
	Rotation angle	+/-130 °	+/-145 °	—	+/-360 °
AC servo motor output		400 W	200 W	200 W	200 W
Deceleration mechanism	Speed reducer	Harmonic drive	Harmonic drive	Ball screw	Harmonic drive
	Transmission method	Direct-coupled			
	Motor to speed reducer	Direct-coupled			
	Speed reducer to output	Direct-coupled			
Repeatability <sup>Note 1</sup>		+/-0.01 mm	+/-0.01 mm	+/-0.01 mm	+/-0.004 °
Maximum speed		8.4 m/sec	2.3 m/sec	1.7 m/sec	1700 °/sec
Maximum payload		8 kg			
Standard cycle time: with 2kg payload <sup>Note 2</sup>		0.56 sec			
R-axis tolerable moment of inertia <sup>Note 3</sup>		0.3 kgm <sup>2</sup>			
Protection class <sup>Note 4</sup>		Equivalent to IP65 (IEC 60529)			
User wiring (sq × wires)		0.2 × 20			
User tubing (Outer diameter)		φ 6 × 3			
Travel limit		1.Soft limit 2.Mechanical stopper (X,Y,Z axis)			
Robot cable length		Standard: 3.5 m Option: 5 m, 10 m			
Weight		Z axis 200 mm: 33 kg Z axis 300 mm: 34 kg			

Note 1. This is the value at a constant ambient temperature. (X,Y axes)  
 Note 2. When reciprocating 25mm in vertical direction and 300mm in horizontal direction (rough-positioning arch motion).  
 Note 3. There are limits to acceleration coefficient settings. See P.539.  
 Note 4. Do not use robots where the bellows section is directly exposed to water jet. Contact our distributor for information on drip-proof structure preventing liquid other than water.

## Controller

Controller	Power capacity (VA)	Operation method
RCX340 RCX240-R3	1700	Programming / I/O point trace / Remote command / Operation using RS-232C communication

Note. "Harmonic" and "Harmonic drive" are the registered trademarks of Harmonic Drive Systems Inc.  
 Note. The movement range can be limited by changing the positions of X and Y axis mechanical stoppers. (The movement range is set to the maximum at the time of shipment.)  
 See our robot manuals (installation manuals) for detailed information.  
 Note. To set the standard coordinates with high accuracy, use a standard coordinate setting jig (option). Refer to the user's manual (installation manual) for more details.

Our robot manuals (installation manuals) can be downloaded from our website at the address below:  
<http://global.yamaha-motor.com/business/robot/>

## YK600XGP

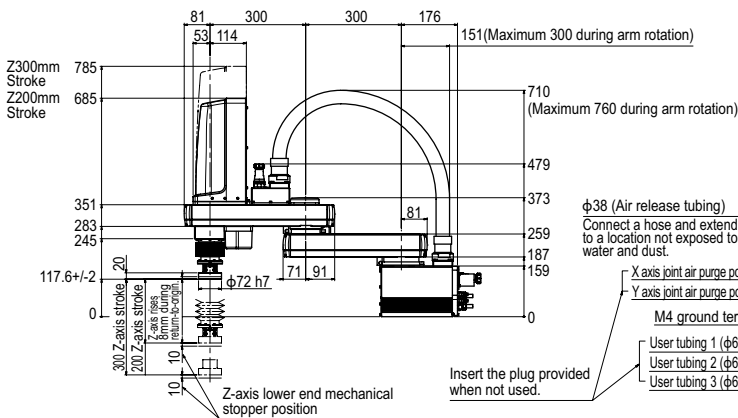
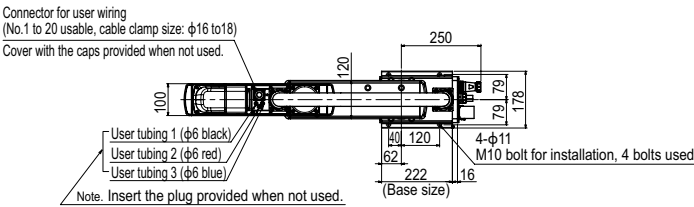

If the robot enters the inside of the corner of dimensions 135 and 292, the Z-axis tip flange may be in contact with the base or the arm may be in contact with the machine harness. So, do not perform such motion.

### Working envelope of left-handed system

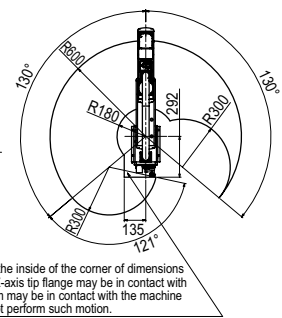

### Working envelope of right-handed system

- Note that the robot cannot be used at a position where the base flange, robot cable, spline, and bellows interfere with each other in the working envelope shown above.
- X-axis mechanical stopper position : 132°
- Y-axis mechanical stopper position : 147°

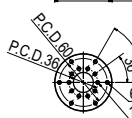
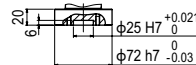

\* There is no phase relation between each position of M5 tapped holes and R-axis origin position.

# YK600XGHP

Dust-proof & drip-proof type

- Arm length 600mm
- Maximum payload 18kg

## Ordering method

**YK600XGHP** - **F** - **RCX340-4** - **R3** - **BB**

Model      Z axis stroke      Tool flange      Cable      Controller / Number of controllable axes      Safety standard      Option A (OP.A)      Option B (OP.B)      Option C (OP.C)      Option D (OP.D)      Option E (OP.E)      Absolute battery

200: 200mm      F: With tool flange      3L: 3.5m      RCX340      R3      BB

400: 400mm      5L: 5m      10L: 10m

Specify various controller setting items. RCX340 ▶ **P.508**

Specify various controller setting items. RCX240/RCX240S ▶ **P.495**

Controller      CE Marking      Regenerative unit      Expansion I/O      Network option      IVY System      Gripper      Battery

## Specifications

		X-axis	Y-axis	Z-axis	R-axis
Axis specifications	Arm length	200 mm	400 mm	200 mm / 400 mm	-
	Rotation angle	+/-130 °	+/-150 °	-	+/-360 °
AC servo motor output		750 W	400 W	400 W	200 W
Deceleration mechanism	Speed reducer	Harmonic drive	Harmonic drive	Ball screw	Harmonic drive
	Transmission method	Direct-coupled			
	Motor to speed reducer Speed reducer to output	Direct-coupled			
Repeatability <sup>Note 1</sup>		+/-0.02 mm	+/-0.01 mm	+/-0.01 mm	+/-0.004 °
Maximum speed		7.7 m/sec	2.3 m/sec	1.7 m/sec	920 °/sec
Maximum payload		18 kg			
Standard cycle time: with 2kg payload <sup>Note 2</sup>		0.57 sec			
R-axis tolerable moment of inertia <sup>Note 3</sup>		1.0 kgm <sup>2</sup>			
Protection class <sup>Note 4</sup>		Equivalent to IP65 (IEC 60529)			
User wiring (sq × wires)		0.2 × 20			
User tubing (Outer diameter)		φ 6 × 3			
Travel limit		1. Soft limit    2. Mechanical stopper (X,Y,Z axis)			
Robot cable length		Standard: 3.5 m    Option: 5 m, 10 m			
Weight		Z axis 200 mm: 52 kg    Z axis 400 mm: 54 kg			

Note 1. This is the value at a constant ambient temperature. (X,Y axes)  
 Note 2. When reciprocating 25mm in vertical direction and 300mm in horizontal direction (rough-positioning arch motion).  
 Note 3. There are limits to acceleration coefficient settings. See P.539.  
 Note 4. Do not use robots where the bellows section is directly exposed to water jet. Contact our distributor for information on drip-proof structure preventing liquid other than water.

## Controller

Controller	Power capacity (VA)	Operation method
RCX340 RCX240-R3	2500	Programming / I/O point trace / Remote command / Operation using RS-232C communication

Note. "Harmonic" and "Harmonic drive" are the registered trademarks of Harmonic Drive Systems Inc.  
 Note. The movement range can be limited by changing the positions of X and Y axis mechanical stoppers. (The movement range is set to the maximum at the time of shipment.) See our robot manuals (installation manuals) for detailed information.  
 Note. To set the standard coordinates with high accuracy, use a standard coordinate setting jig (option). Refer to the user's manual (installation manual) for more details.

Our robot manuals (installation manuals) can be downloaded from our website at the address below:  
<http://global.yamaha-motor.com/business/robot/>

## YK600XGHP

Connector for user wiring (No.1 to 20 usable, cable clamp size: φ16 to 18)  
 Cover with the caps provided when not used.

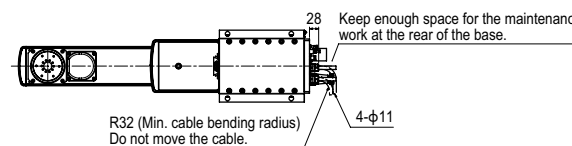
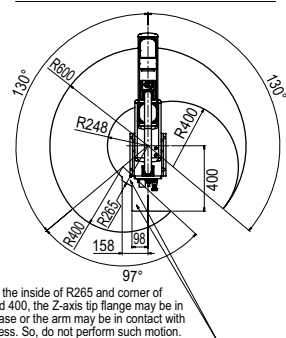
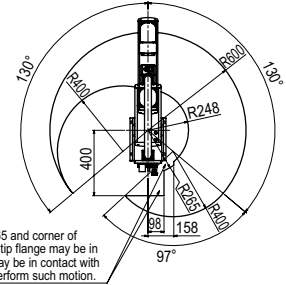
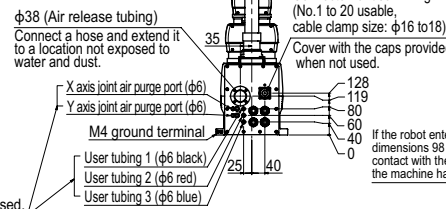
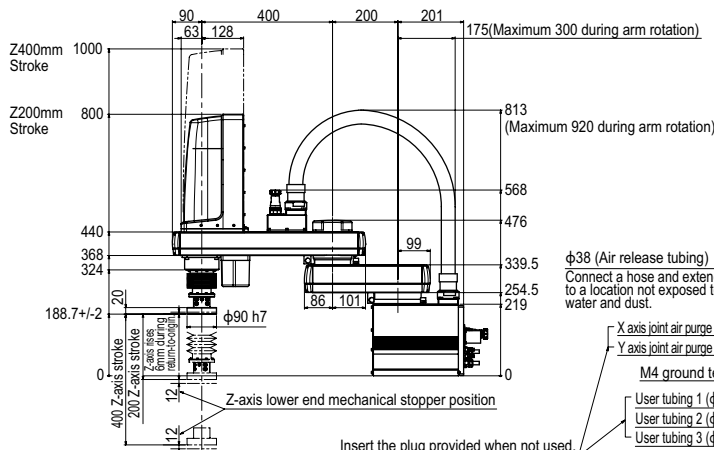
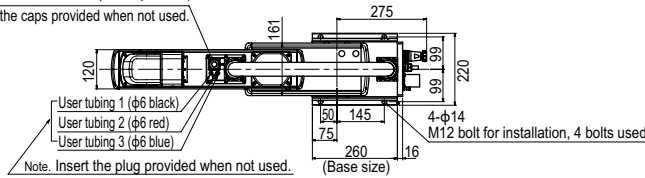

APPLICATION  
 Linear conveyor/ modules  
 LCM100

Compact  
 single-axis robots  
 TRANSERVO

Single-axis robots  
 FLIP-X

Linear motor  
 single-axis robots  
 PHASER

Cartesian  
 robots  
 X-X

SCARA  
 robots  
 YK-X

Pick & place  
 robots  
 YP-X

CLEAN

CONTROLLER INFORMATION

Orbit / Triy type  
 Small / Medium type

Large type  
 Inverse type

Dust-proof & drip-proof type



# YK700XGP

Dust-proof & drip-proof type



- Arm length 700mm
- Maximum payload 18kg

## Ordering method

**YK700XGP** **F** **RCX340-4**

Model      Z axis stroke      Tool flange      Cable

200: 200mm      F: With tool flange      3L: 3.5m      Controller / Number of controllable axes

400: 400mm      5L: 5m      10L: 10m      Safety standard      Option A (OP.A)      Option B (OP.B)      Option C (OP.C)      Option D (OP.D)      Option E (OP.E)      Absolute battery

**Specify various controller setting items. RCX340 ▶ P.508**

**RCX240** **R3** **BB**

Controller      CE Marking      Regenerative unit      Expansion I/O      Network option      iVY System      Gripper      Battery

**Specify various controller setting items. RCX240/RCX240S ▶ P.495**

## Specifications

		X-axis	Y-axis	Z-axis	R-axis
Axis specifications	Arm length	300 mm	400 mm	200 mm	400 mm
	Rotation angle	+/-130 °	+/-150 °	-	+/-360 °
AC servo motor output		750 W	400 W	400 W	200 W
Deceleration mechanism	Speed reducer	Harmonic drive	Harmonic drive	Ball screw	Harmonic drive
	Transmission method	Direct-coupled			
	Motor to speed reducer	Direct-coupled			
Speed reducer to output		Direct-coupled			
Repeatability <sup>Note 1</sup>		+/-0.02 mm	+/-0.01 mm	+/-0.004 °	
Maximum speed		8.4 m/sec	2.3 m/sec	1.7 m/sec	920 °/sec
Maximum payload		18 kg			
Standard cycle time: with 2kg payload <sup>Note 2</sup>		0.52 sec			
R-axis tolerable moment of inertia <sup>Note 3</sup>		1.0 kgm <sup>2</sup>			
Protection class <sup>Note 4</sup>		Equivalent to IP65 (IEC 60529)			
User wiring		0.2 sq × 20 wires			
User tubing (Outer diameter)		φ 6 × 3			
Travel limit		1.Soft limit 2.Mechanical stopper (X,Y,Z axis)			
Robot cable length		Standard: 3.5 m Option: 5 m, 10 m			
Weight		Z axis 200 mm: 54 kg Z axis 400 mm: 56 kg			

Note 1. This is the value at a constant ambient temperature. (X,Y axes)  
 Note 2. When reciprocating 25mm in vertical direction and 300mm in horizontal direction (rough-positioning arch motion).  
 Note 3. There are limits to acceleration coefficient settings. See P.539.  
 Note 4. Do not use robots where the bellows section is directly exposed to water jet. Contact our distributor for information on drip-proof structure preventing liquid other than water.

## Controller

Controller	Power capacity (VA)	Operation method
RCX340 RCX240-R3	2500	Programming / I/O point trace / Remote command / Operation using RS-232C communication

Note. "Harmonic" and "Harmonic drive" are the registered trademarks of Harmonic Drive Systems Inc.  
 Note. The movement range can be limited by changing the positions of X and Y axis mechanical stoppers. (The movement range is set to the maximum at the time of shipment.)  
 See our robot manuals (installation manuals) for detailed information.  
 Note. To set the standard coordinates with high accuracy, use a standard coordinate setting jig (option). Refer to the user's manual (installation manual) for more details.

Our robot manuals (installation manuals) can be downloaded from our website at the address below:  
<http://global.yamaha-motor.com/business/robot/>

## YK700XGP

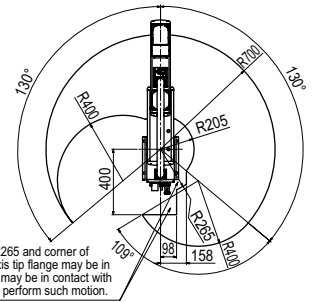
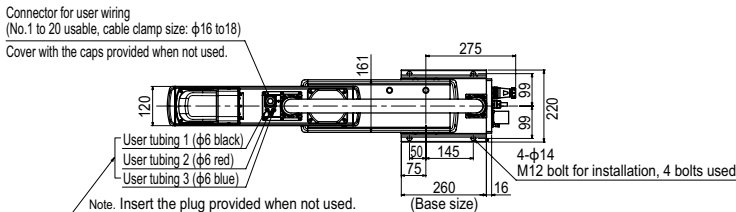

If the robot enters the inside of R265 and corner of dimensions 90 and 400, the Z-axis tip flange may be in contact with the base or the arm may be in contact with the machine harness. So, do not perform such motion.

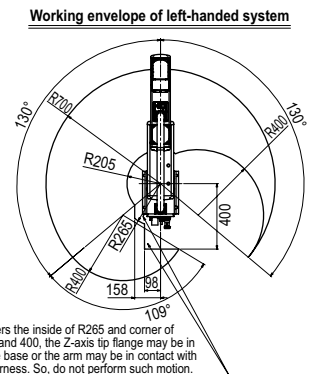

If the robot enters the inside of R265 and corner of dimensions 90 and 400, the Z-axis tip flange may be in contact with the base or the arm may be in contact with the machine harness. So, do not perform such motion.

## Working envelope of right-handed system

- Note that the robot cannot be used at a position where the base flange, robot cable, spline, and bellows interfere with each other in the working envelope shown above.
- X-axis mechanical stopper position : 132°
- Y-axis mechanical stopper position : 152°

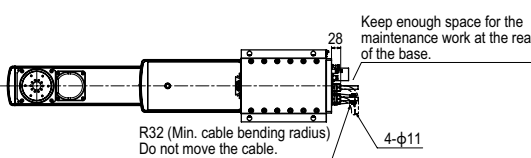
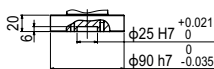
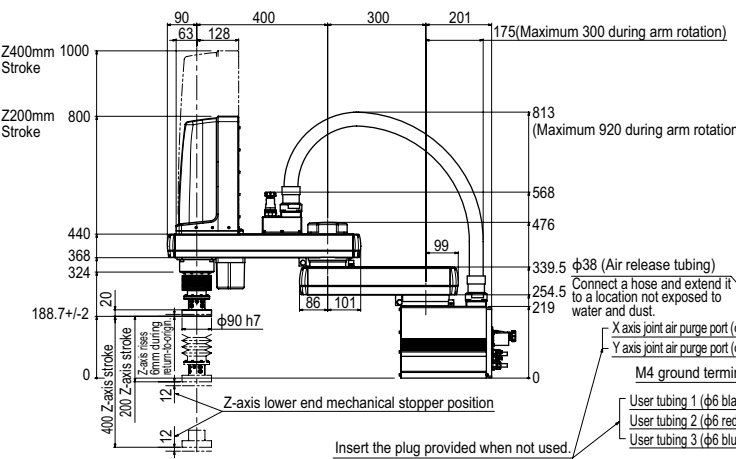

# YK800XGP

Dust-proof & drip-proof type

- Arm length 800mm
- Maximum payload 18kg

## Ordering method

**YK800XGP** **F** **RCX340-4**

Model	Z axis stroke	Tool flange	Cable	Controller / Number of controllable axes	Safety standard	Option A (OP.A)	Option B (OP.B)	Option C (OP.C)	Option D (OP.D)	Option E (OP.E)	Absolute battery
	200: 200mm 400: 400mm	F: With tool flange	3L: 3.5m 5L: 5m 10L: 10m	Specify various controller setting items. RCX340 ▶ <b>P.508</b>							

**RCX240** **R3** **BB**

Controller	CE Marking	Regenerative unit	Expansion I/O	Network option	iVY System	Gripper	Battery

Specify various controller setting items. RCX240/RCX240S ▶ **P.495**

## Specifications

		X-axis	Y-axis	Z-axis	R-axis
Axis specifications	Arm length	400 mm	400 mm	200 mm	400 mm
	Rotation angle	+/-130 °	+/-150 °	-	+/-360 °
AC servo motor output		750 W	400 W	400 W	200 W
Deceleration mechanism	Speed reducer	Harmonic drive	Harmonic drive	Ball screw	Harmonic drive
	Transmission method	Motor to speed reducer	Direct-coupled		
		Speed reducer to output	Direct-coupled		
Repeatability <sup>Note 1</sup>		+/-0.02 mm	+/-0.01 mm	+/-0.01 mm	+/-0.004 °
Maximum speed		9.2 m/sec	2.3 m/sec	1.7 m/sec	920 °/sec
Maximum payload		18 kg			
Standard cycle time: with 2kg payload <sup>Note 2</sup>		0.58 sec			
R-axis tolerable moment of inertia <sup>Note 3</sup>		1.0 kgm <sup>2</sup>			
Protection class <sup>Note 4</sup>		Equivalent to IP65 (IEC 60529)			
User wiring		0.2 sq × 20 wires			
User tubing (Outer diameter)		φ 6 × 3			
Travel limit		1.Soft limit 2.Mechanical stopper (X,Y,Z axis)			
Robot cable length		Standard: 3.5 m Option: 5 m, 10 m			
Weight		Z axis 200 mm: 56 kg Z axis 400 mm: 58 kg			

Note 1. This is the value at a constant ambient temperature. (X,Y axes)  
 Note 2. When reciprocating 25mm in vertical direction and 300mm in horizontal direction (rough-positioning arch motion).  
 Note 3. There are limits to acceleration coefficient settings. See P.539.  
 Note 4. Do not use robots where the bellows section is directly exposed to water jet. Contact our distributor for information on drip-proof structure preventing liquid other than water.

## Controller

Controller	Power capacity (VA)	Operation method
RCX340 RCX240-R3	2500	Programming / I/O point trace / Remote command / Operation using RS-232C communication

Note. "Harmonic" and "Harmonic drive" are the registered trademarks of Harmonic Drive Systems Inc.  
 Note. The movement range can be limited by changing the positions of X and Y axis mechanical stoppers. (The movement range is set to the maximum at the time of shipment.)  
 See our robot manuals (installation manuals) for detailed information.  
 Note. To set the standard coordinates with high accuracy, use a standard coordinate setting jig (option). Refer to the user's manual (installation manual) for more details.

Our robot manuals (installation manuals) can be downloaded from our website at the address below:  
<http://global.yamaha-motor.com/business/robot/>

## YK800XGP

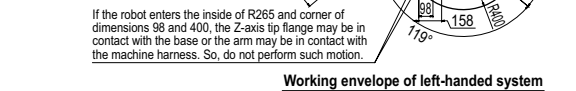
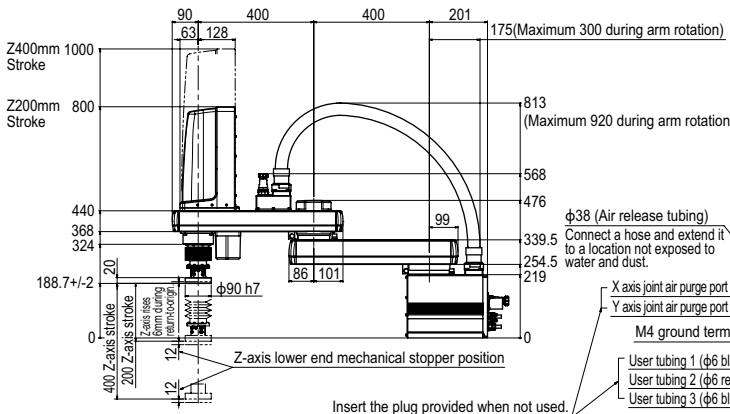
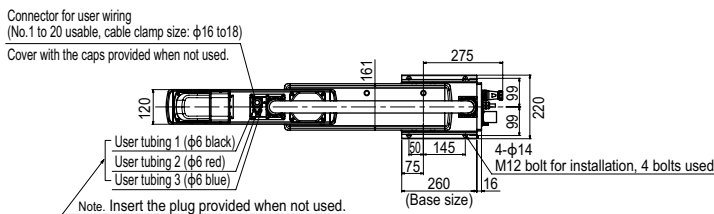

If the robot enters the inside of R265 and corner of dimensions 98 and 400, the Z-axis tip flange may be in contact with the base or the arm may be in contact with the machine harness. So, do not perform such motion.

Working envelope of left-handed system

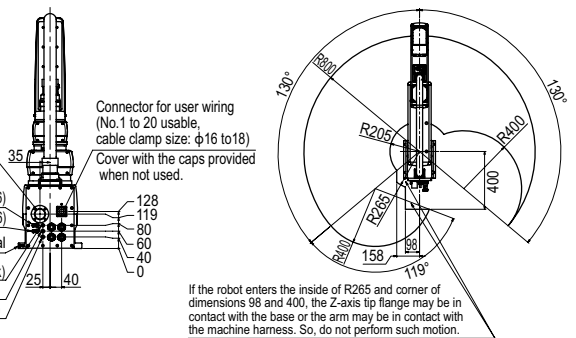

If the robot enters the inside of R265 and corner of dimensions 98 and 400, the Z-axis tip flange may be in contact with the base or the arm may be in contact with the machine harness. So, do not perform such motion.

Working envelope of right-handed system

- Note that the robot cannot be used at a position where the base flange, robot cable, spline, and bellows interfere with each other in the working envelope shown above.
- X-axis mechanical stopper position : 132°
- Y-axis mechanical stopper position : 152°

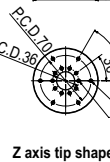
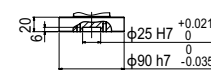

Z axis tip shape

APPLICATION  
 Linear conveyor/ modules  
 LCM100  
 Compact single-axis robots  
 TRANSERVO  
 Single-axis robots  
 FLIP-X  
 Linear motor single-axis robots  
 PHASER  
 Cartesian robots  
 XX-X  
 SCARA robots  
 YK-X  
 Pick & place robots  
 YP-X  
 CLEAN  
 CONTROLLER INFORMATION  
 Orbit / TriV type  
 Small / Medium type  
 Large type  
 Walk-mount / Inverse type  
 Dust-proof & drip-proof type

# YK900XGP

Dust-proof & drip-proof type

- Arm length 900mm
- Maximum payload 18kg

## Ordering method

**YK900XGP** **F** **RCX340-4**

Model      Z axis stroke      Tool flange      Cable

200: 200mm      F: With tool flange      3L: 3.5m      Controller / Number of controllable axes

400: 400mm      5L: 5m      10L: 10m      Safety standard      Option A (OP.A)      Option B (OP.B)      Option C (OP.C)      Option D (OP.D)      Option E (OP.E)      Absolute battery

**Specify various controller setting items. RCX340 ▶ P.508**

**RCX240** **R3** **BB**

Controller      CE Marking      Regenerative unit      Expansion I/O      Network option      iVY System      Gripper      Battery

**Specify various controller setting items. RCX240/RCX240S ▶ P.495**

## Specifications

		X-axis	Y-axis	Z-axis	R-axis
Axis specifications	Arm length	500 mm	400 mm	200 mm 400 mm	—
	Rotation angle	+/-130 °	+/-150 °	—	+/-360 °
AC servo motor output		750 W	400 W	400 W	200 W
Deceleration mechanism	Speed reducer	Harmonic drive	Harmonic drive	Ball screw	Harmonic drive
	Transmission method	Direct-coupled			
	Motor to speed reducer	Direct-coupled			
	Speed reducer to output	Direct-coupled			
Repeatability <sup>Note 1</sup>		+/-0.02 mm	+/-0.01 mm	+/-0.01 mm	+/-0.004 °
Maximum speed		9.9 m/sec	2.3 m/sec	1.7 m/sec	920 °/sec
Maximum payload		18 kg			
Standard cycle time: with 2kg payload <sup>Note 2</sup>		0.59 sec			
R-axis tolerable moment of inertia <sup>Note 3</sup>		1.0 kgm <sup>2</sup>			
Protection class <sup>Note 4</sup>		Equivalent to IP65 (IEC 60529)			
User wiring (sq × wires)		0.2 × 20			
User tubing (Outer diameter)		φ 6 × 3			
Travel limit		1.Soft limit 2.Mechanical stopper (X,Y,Z axis)			
Robot cable length		Standard: 3.5 m Option: 5 m, 10 m			
Weight		Z axis 200 mm: 58 kg Z axis 400 mm: 60 kg			

Note 1. This is the value at a constant ambient temperature. (X,Y axes)

Note 2. When reciprocating 25mm in vertical direction and 300mm in horizontal direction (rough-positioning arch motion).

Note 3. There are limits to acceleration coefficient settings. See P.539.

Note 4. Do not use robots where the bellows section is directly exposed to water jet. Contact our distributor for information on drip-proof structure preventing liquid other than water.

## Controller

Controller	Power capacity (VA)	Operation method
RCX340 RCX240-R3	2500	Programming / I/O point trace / Remote command / Operation using RS-232C communication

Note. "Harmonic" and "Harmonic drive" are the registered trademarks of Harmonic Drive Systems Inc.

Note. The movement range can be limited by changing the positions of X and Y axis mechanical stoppers. (The movement range is set to the maximum at the time of shipment.) See our robot manuals (installation manuals) for detailed information.

Note. To set the standard coordinates with high accuracy, use a standard coordinate setting jig (option). Refer to the user's manual (installation manual) for more details.

Our robot manuals (installation manuals) can be downloaded from our website at the address below:  
<http://global.yamaha-motor.com/business/robot/>

## YK900XGP

Connector for user wiring (No.1 to 20 usable, cable clamp size: φ16 to18)

Cover with the caps provided when not used.

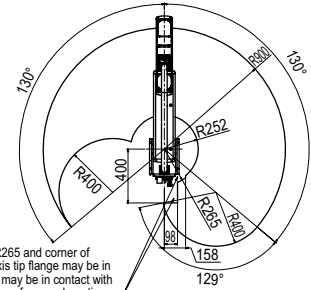
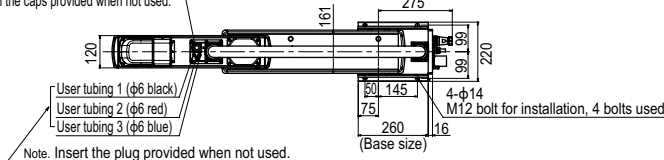

Working envelope of left-handed system

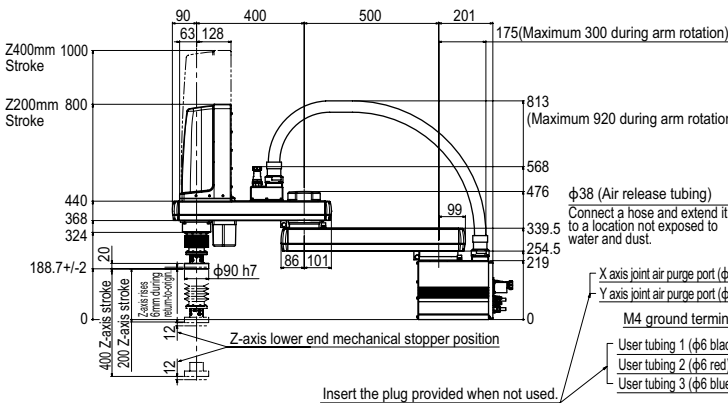

Connector for user wiring (No.1 to 20 usable, cable clamp size: φ16 to18)  
Cover with the caps provided when not used.

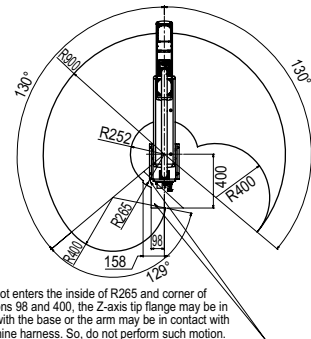

Working envelope of right-handed system

- Note that the robot cannot be used at a position where the base flange, robot cable, spline, and bellows interfere with each other in the working envelope shown above.
- X-axis mechanical stopper position : 132°
- Y-axis mechanical stopper position : 152°

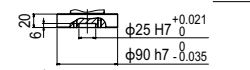

Z axis tip shape

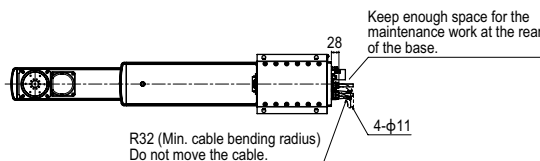

# YK1000XGP

Dust-proof & drip-proof type

- Arm length 1000mm
- Maximum payload 18kg

## Ordering method

**YK1000XGP** **F** **RCX340-4**

Model	Z axis stroke	Tool flange	Cable	Controller / Number of controllable axes	Safety standard	Option A (OP.A)	Option B (OP.B)	Option C (OP.C)	Option D (OP.D)	Option E (OP.E)	Absolute battery
	200: 200mm 400: 400mm	F: With tool flange	3L: 3.5m 5L: 5m 10L: 10m								

Specify various controller setting items. RCX340 ▶ **P.508**

**RCX240** **R3** **BB**

Controller	CE Marking	Regenerative unit	Expansion I/O	Network option	IVY System	Gripper	Battery

Specify various controller setting items. RCX240/RCX240S ▶ **P.495**

## Specifications

		X-axis	Y-axis	Z-axis	R-axis
<b>Axis specifications</b>	<b>Arm length</b>	600 mm	400 mm	200 mm / 400 mm	—
	<b>Rotation angle</b>	+/-130 °	+/-150 °	—	+/-360 °
<b>AC servo motor output</b>		750 W	400 W	400 W	200 W
<b>Deceleration mechanism</b>	<b>Speed reducer</b>	Harmonic drive	Harmonic drive	Ball screw	Harmonic drive
	<b>Transmission method</b>	Direct-coupled			
	<b>Motor to speed reducer</b>	Direct-coupled			
	<b>Speed reducer to output</b>	Direct-coupled			
<b>Repeatability</b> <small>Note 1</small>		+/-0.02 mm	+/-0.01 mm	+/-0.01 mm	+/-0.004 °
<b>Maximum speed</b>		10.6 m/sec	2.3 m/sec	1.7 m/sec	920 °/sec
<b>Maximum payload</b>		18 kg			
<b>Standard cycle time: with 2kg payload</b> <small>Note 2</small>		0.59 sec			
<b>R-axis tolerable moment of inertia</b> <small>Note 3</small>		1.0 kgm <sup>2</sup>			
<b>Protection class</b> <small>Note 4</small>		Equivalent to IP65 (IEC 60529)			
<b>User wiring (sq × wires)</b>		0.2 × 20			
<b>User tubing (Outer diameter)</b>		φ 6 × 3			
<b>Travel limit</b>		1.Soft limit 2.Mechanical stopper (X,Y,Z axis)			
<b>Robot cable length</b>		Standard: 3.5 m Option: 5 m, 10 m			
<b>Weight</b>		Z axis 200 mm: 60 kg Z axis 400 mm: 62 kg			

Note 1. This is the value at a constant ambient temperature. (X,Y axes)  
 Note 2. When reciprocating 25mm in vertical direction and 300mm in horizontal direction (rough-positioning arch motion).  
 Note 3. There are limits to acceleration coefficient settings. See P.539.  
 Note 4. Do not use robots where the bellows section is directly exposed to water jet. Contact our distributor for information on drip-proof structure preventing liquid other than water.

## Controller

Controller	Power capacity (VA)	Operation method
RCX340 RCX240-R3	2500	Programming / I/O point trace / Remote command / Operation using RS-232C communication

Note. "Harmonic" and "Harmonic drive" are the registered trademarks of Harmonic Drive Systems Inc.  
 Note. The movement range can be limited by changing the positions of X and Y axis mechanical stoppers. (The movement range is set to the maximum at the time of shipment.) See our robot manuals (installation manuals) for detailed information.  
 Note. To set the standard coordinates with high accuracy, use a standard coordinate setting jig (option). Refer to the user's manual (installation manual) for more details.

Our robot manuals (installation manuals) can be downloaded from our website at the address below:  
<http://global.yamaha-motor.com/business/robot/>

## YK1000XGP

Connector for user wiring (No.1 to 20 usable, cable clamp size: φ16 to 18)  
 Cover with the caps provided when not used.

User tubing 1 (φ6 black)  
 User tubing 2 (φ6 red)  
 User tubing 3 (φ6 blue)

Note. Insert the plug provided when not used.

φ38 (Air release tubing)  
 Connect a hose and extend it to a location not exposed to water and dust.

X axis joint air purge port (φ6)  
 Y axis joint air purge port (φ6)  
 M4 ground terminal  
 User tubing 1 (φ6 black)  
 User tubing 2 (φ6 red)  
 User tubing 3 (φ6 blue)

Keep enough space for the maintenance work at the rear of the base.

R32 (Min. cable bending radius) Do not move the cable.

φ25 H7 0  
 φ90 h7 -0.035

P.C.D. 20  
 P.C.D. 36  
 6-M5×0.8 Depth 11  
 10-M5×0.8 Depth 11  
 \*There is no phase relation between each position of M5 tapped holes and R-axis origin position.

**Z axis tip shape**

**Working envelope of left-handed system**

**Working envelope of right-handed system**

- Note that the robot cannot be used at a position where the base flange, robot cable, spline, and bellows interfere with each other in the working envelope shown above.
- X-axis mechanical stopper position : 132°
- Y-axis mechanical stopper position : 152°

APPLICATION  
 Linear conveyor / modules  
 LCM100

TRANSEURO  
 Compact single-axis robots

FLIP-X  
 Single-axis robots

PHASER  
 Linear motor single-axis robots

XX-X  
 Cartesian robots

YK-X  
 SCA RA robots

YP-X  
 Pick & place robots

CLEAN  
 CLEAN

CONTROLLER INFORMATION  
 Orbit / TriV type  
 Small / Medium type  
 Large type  
 Walk-mount / Inverse type  
 Dust-proof & drip-proof type

# MEMO

---

---

APPLICATION

Linear conveyor  
modules  
**LCM100**

Compact  
single-axis robots  
**TRANSERVO**

Single-axis robots  
**FLIP-X**

Linear motor  
single-axis robots  
**PHASER**

Cartesian  
robots  
**XY-X**

SCARA  
robots  
**YK-X**

Pick & place  
robots  
**YP-X**

**CLEAN**

**CONTROLLER**

**INFORMATION**

Orbit / Tiny  
type

Small /  
Medium type

Large type

Wall-mount /  
Inverse type

Dust-proof  
& drip-proof  
type