

APPLICATION  
TRANSEURO  
FLIP-X  
PHASER  
XY-X  
YK-XG  
YP-X  
CLEAN  
CONTROLLER INFORMATION  
Arm type  
Gantry type  
Moving arm  
Pole type  
XZ type

# HXYx 2 axes

● Arm type ● Cable carrier



## Ordering method

<b>HXYx - C</b>					<b>RCX222HP</b>		<b>R</b>			
Model	Cable	Combination	X-axis stroke	Y-axis stroke	Cable length	Controller	Usable for CE marking	Regenerative unit	Input/Output selection 1	Input/Output selection 2
A1			25 to 125cm	25 to 65cm	3L: 3.5m (Standard) 5L: 5m 10L: 10m	RCX222HP DRCX2020	No entry: Standard E: CE marking	R: RG2 (RCX221) R: RGU-2 (DRCX)	N: NPN <sup>Note 1</sup> P: PNP CC: CC-Link DN: DeviceNet PB: Profibus EN: Ethernet <sup>Note 1</sup> YC: YC-Link <sup>Note 2</sup>	No entry: None N1: OPDIO24/16 (PNP) <sup>Note 1</sup> P1: OPDIO24/17 (PNP) EN: Ethernet <sup>Note 1</sup> EN: Ethernet <sup>Note 1</sup>

Note 1. NPN and Ethernet cannot be selected if using CE marking.  
Note 2. Available only for the master.  
Note 3. Only when CC or DN or PB was selected for I/O select 1 above. EN can be selected in I/O select 2.

## Specification

	X-axis	Y-axis
Axis construction <sup>Note 1</sup>	F20	F17
AC servo motor output (W)	600	400
Repeatability <sup>Note 2</sup> (mm)	+/-0.01	+/-0.01
Drive system	Ball screw (Class C7)	Ball screw (Class C7)
Ball screw lead (Deceleration ratio) (mm)	20	20
Maximum speed <sup>Note 3</sup> (mm/sec)	1200	1200
Moving range (mm)	250 to 1250	250 to 650
Robot cable length (m)	Standard: 3.5 Option: 5,10	

Note 1. Use caution that the flame machining (installation holes, tap holes) differs from single-axis robots.  
Note 2. Positioning repeatability in one direction.  
Note 3. When the X-axis stroke is longer than 850mm, resonance of the ball screw may occur depending on the operation conditions (critical speed). In this case, reduce the speed setting on the program by referring to the maximum speeds shown in the table below.

## Maximum payload (kg)

Y stroke (mm)	XY 2 axes
250	40
350	40
450	35
550	30
650	30

## Controller

Controller	Operation method
RCX222HP-R	Programming / I/O point trace / Remote command / Operation using RS-232C communication
DRCX2020-R	

## HXYx 2 axes A1

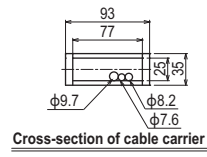
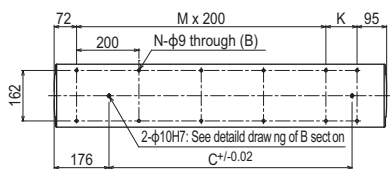
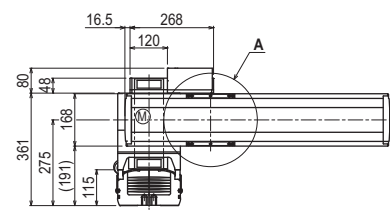
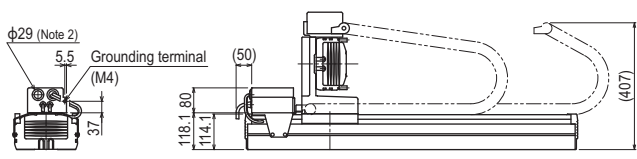
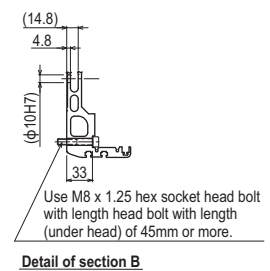
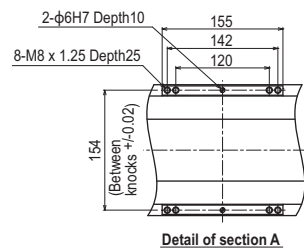
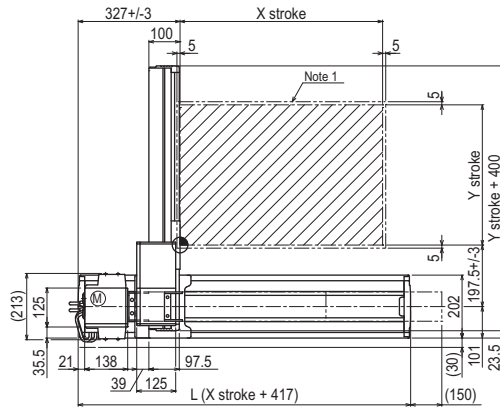

X stroke	250	350	450	550	650	750	850	950	1050	1150	1250
L	667	767	867	967	1067	1167	1267	1367	1467	1567	1667
K	100	200	100	200	100	200	100	200	100	200	100
C	420	420	600	600	780	780	960	960	1140	1320	1320
M	2	2	3	3	4	4	5	5	6	6	7
N	8	8	10	10	12	12	14	14	16	16	18
Y stroke	250	350	450	550	650						
Maximum speed for each stroke (mm/sec) <sup>Note 3</sup>	X-axis		1200				960	840	720	600	480
Speed setting			-				80%	70%	60%	50%	40%

Note 1. The moving range when returning to origin and the stop position when stopping by the mechanical stopper.  
Note 2. User cable extraction port.

Note 3. When the X-axis stroke is longer than 850mm, resonance of the ball screw may occur depending on the operation conditions (critical speed). In this case, reduce the speed setting on the program by referring to the maximum speeds shown in the table at the left.

HXYx 2 axes **A2**

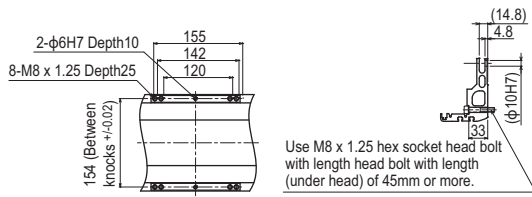

Detail of section A

Detail of section B

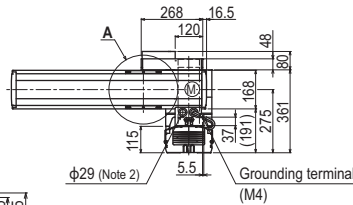

Cross-section of cable carrier

2-φ10H7: See detail drawing of B section

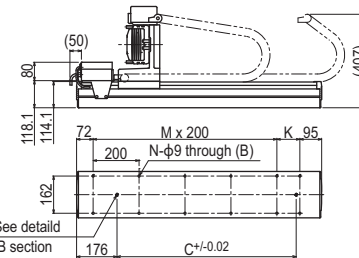
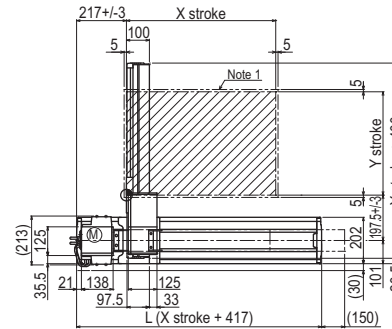

HXYx 2 axes **A3**

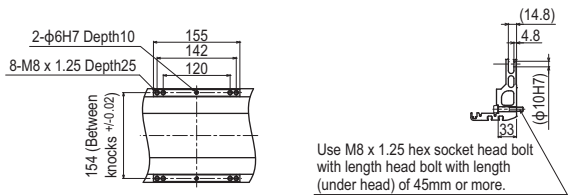

Detail of section A

Detail of section B

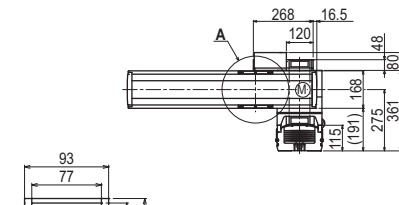

Cross-section of cable carrier

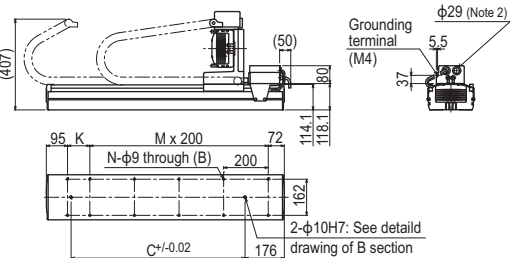
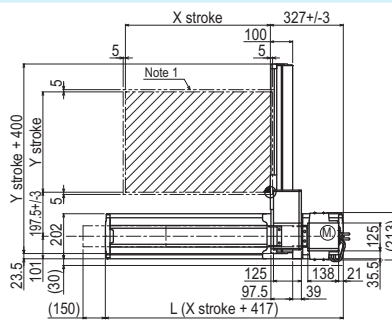

HXYx 2 axes **A4**

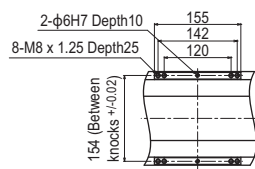
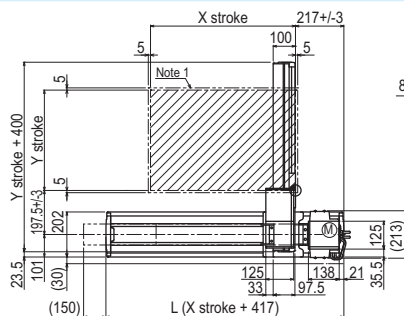

Detail of section A

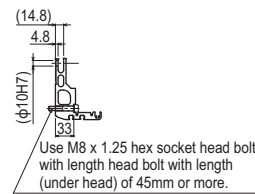

Detail of section B

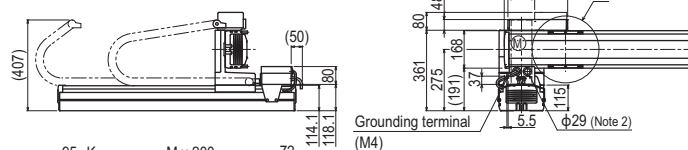

Cross-section of cable carrier

2-φ10H7: See detail drawing of B section